



User Guide

SI-POWERLINK

Part Number: 0478-0617-01
Issue Number: 1

Original Instructions

For the purposes of compliance with the EU Machinery Directive 2006/42/EC, the English version of this manual is the Original Instructions. Manuals in other languages are Translations of the Original Instructions.

Documentation

Manuals are available to download from the following locations:

<http://www.drive-setup.com/ctdownloads>

The information contained in this manual is believed to be correct at the time of printing and does not form part of any contract. The manufacturer reserves the right to change the specification of the product and its performance, and the contents of the manual, without notice.

Warranty and Liability

In no event and under no circumstances shall the manufacturer be liable for damages and failures due to misuse, abuse, improper installation, or abnormal conditions of temperature, dust, or corrosion, or failures due to operation outside the published ratings. The manufacturer is not liable for consequential and incidental damages. Contact the supplier of the dive for full details of the warranty terms.

Environmental policy

Control Techniques Ltd operates an Environmental Management System (EMS) that conforms to the International Standard ISO 14001.

Further information on our Environmental Policy can be found at:

<http://www.drive-setup.com/environment>

Restriction of Hazardous Substances (RoHS)

The products covered by this manual comply with European and International regulations on the Restriction of Hazardous Substances including EU directive 2011/65/EU and the Chinese Administrative Measures for Restriction of Hazardous Substances in Electrical and Electronic Products.

Disposal and Recycling (WEEE)



When electronic products reach the end of their useful life, they must not be disposed of along with domestic waste but should be recycled by a specialist recycler of electronic equipment. Control Techniques products are designed to be easily dismantled into their major component parts for efficient recycling. The majority of materials used in the product are suitable for recycling.

Product packaging is of good quality and can be re-used. Large products are packed in wooden crates. Smaller products are packaged in strong cardboard cartons which have a high recycled fibre content. Cartons can be re-used and recycled. Polythene, used in protective film and bags for wrapping the product, can be recycled. When preparing to recycle or dispose of any product or packaging, please observe local legislation and best practice.

REACH legislation

EC Regulation 1907/2006 on the Registration, Evaluation, Authorisation and restriction of Chemicals (REACH) requires the supplier of an article to inform the recipient if it contains more than a specified proportion of any substance which is considered by the European Chemicals Agency (ECHA) to be a Substance of Very High Concern (SVHC) and is therefore listed by them as a candidate for compulsory authorisation.

Further information on our compliance with REACH can be found at: <http://www.drive-setup.com/reach>

Registered Office

Nidec Control Techniques Ltd

**The Gro
Newtown
Powys
SY16 3BE
UK**

Registered in England and Wales. Company Reg. No. 01236886.

Copyright

The contents of this publication are believed to be correct at the time of printing. In the interests of a commitment to a policy of continuous development and improvement, the manufacturer reserves the right to change the specification of the product or its performance, or the contents of the guide, without notice.

All rights reserved. No parts of this guide may be reproduced or transmitted in any form or by any means, electrical or mechanical including photocopying, recording or by an information storage or retrieval system, without permission in writing from the publisher.

Copyright © December 2020 Nidec Control Techniques Ltd

Contents

1	Safety information	6
1.1	Warnings, Cautions and Notes	6
1.2	Installation and use	6
1.3	Enclosure	6
1.4	Competence of the installer	6
1.5	Repairs	7
1.6	Electric Shock and Fire Hazards	7
1.7	Electrical installation	7
1.8	Setting up, commissioning and maintenance	8
1.9	Safety of machinery, safety-critical applications	9
1.10	Electromagnetic compatibility (EMC)	9
1.11	Copyright	9
2	Introduction	10
2.1	Products covered by this User Guide	10
2.2	Firmware Statement	10
2.3	What is POWERLINK?	10
2.4	About SI-POWERLINK	11
2.5	Features	11
2.6	Option module identification	11
2.7	Conventions used in this guide	12
3	Mechanical installation	13
3.1	General installation	13
4	Electrical installation	16
4.1	SI-POWERLINK module information	16
4.2	SI-POWERLINK terminal descriptions	18
4.3	Module grounding and EMC	18
4.4	Network topology	19
4.5	Minimum node-to-node cable length	19
4.6	Indicator LEDs	20
4.7	Status and Error LEDs	20
4.8	Tx/Rx and Link LED	20
5	Getting started	21
5.1	Quick start guide	21
5.2	Configuring the SI-POWERLINK module for communications	21
5.3	Adding the XDD descriptor file to Automations Studio	22
5.4	Creating the hardware configuration within Automation Studio	22
5.5	Non-cyclic data - SDO communications example	22
5.6	Cyclic data - PDO communications example	26
6	Supported Objects	28
6.1	Supported objects	28
7	PDO, SDO & POWERLINK Modes	33
7.1	Process Data Objects (PDOs)	33
7.2	Service Data Object (SDO) parameter access	33
7.3	POWERLINK Modes (POWERLINK Mode and Basic Ethernet Mode)	33

8	Object descriptions	35
8.1	Communication Object Descriptions	35
8.2	CANopen (CiA402) for POWERLINK	35
8.3	Communication Object Description	42
8.4	Additional position loop scaling	42
8.5	Error Reaction	43
8.6	Feedback encoder source	44
8.7	Enhanced Loop Control	45
8.8	Moving Average Filter	46
9	Drive profile modes	47
9.1	Common profile features	47
9.2	vl velocity mode	64
9.3	Homing mode	70
9.4	Cyclic synchronous position mode (CSP)	77
9.5	Cyclic synchronous velocity mode (CSV)	80
9.6	Cyclic synchronous torque mode (CST)	82
9.7	Error Handling	85
9.8	Abort connection option code	87
10	Parameter descriptions	88
10.1	Internal menus	88
10.2	Parameter type codes	88
10.3	Parameter descriptions	88
11	Diagnostics	95
11.1	Diagnostic parameters	95
11.2	Error handling	98
11.3	Drive trip display codes	101
11.4	Updating SI-POWERLINK firmware	101
11.5	Switching frequency	102
11.6	SDO abort codes	102
12	Glossary of terms	103

1 Safety information

1.1 Warnings, Cautions and Notes



A **Warning** contains information, which is essential for avoiding a safety hazard.



A **Caution** contains information, which is necessary for avoiding a risk of damage to the product or other equipment.

NOTE A **Note** contains information, which helps to ensure correct operation of the product.

1.2 Installation and use

The information given in this publication is derived from tests and calculations on sample products. It is provided to assist in the correct application of the product, and is believed to correctly reflect the behaviour of the product when operated in accordance with the instructions. The provision of this data does not form part of any contract or undertaking. Where a statement of conformity is made with a specific standard, the manufacturer takes all reasonable measures to ensure that its products are in conformance. Where specific values are given these are subject to normal engineering variations between samples of the same product. They may also be affected by the operating environment and details of the installation arrangement.

The manufacturer accepts no liability for any consequences resulting from inappropriate, negligent or incorrect installation of the equipment.



WARNING - This warning applies to products intended to be used with variable speed drives.

The adjustable speed drive uses high voltages and currents, carries a high level of stored electrical energy, and is used to control mechanical plant which can cause injury. Close attention is required to the electrical installation and the system design to avoid hazards either in normal operation or in the event of equipment malfunction.

System design, installation, commissioning and maintenance must be carried out by personnel who have the necessary training and experience. They must read this safety information and the instruction manual carefully.

Failure to observe the following instructions can cause physical injury or death, or damage to the equipment.

1.3 Enclosure

The drive is intended to be mounted in an enclosure which prevents access except by trained and authorized personnel, and which prevents the ingress of contamination.

It is designed for use in an environment classified as pollution degree 2 in accordance with IEC 60664-1. This means that only dry, non-conducting contamination is acceptable.

1.4 Competence of the installer

The drive must be installed by professional installers who are familiar with the requirements for safety and EMC. The installer is responsible for ensuring that the end product or system complies with all the relevant laws in the country where it is to be used.

1.5 Repairs

Users must not attempt to repair a drive if it is faulty. It must be returned to the supplier of the drive.

1.6 Electric Shock and Fire Hazards

	<p>WARNING - Dangerous voltage</p> <p>Where products are supplied by or connected to mains voltages, the voltages used can cause severe electrical shock and/or burns, and could be lethal. Extreme care is necessary at all times when working with or adjacent to the equipment. Refer to the relevant documentation.</p>
---	--

1.6.1 AC supply

The AC supply must be isolated before any servicing work is performed, other than adjustments to the settings or parameters specified in the manual.

1.6.2 Live terminals

Some types of signal and control lines carry hazardous voltages (120/ 240 V) and can cause severe electric shock and may be lethal.

1.6.3 Isolation device

The AC supply must be removed from the drive using an approved isolation device before any servicing work is performed, other than adjustments to the settings or parameters specified in the manual.

1.6.4 Stored charge

The drive contains capacitors that remain charged to a potentially lethal voltage after the power supply has been disconnected. If the drive has been energized, the power supply must be isolated at least ten minutes before work may continue.

1.7 Electrical installation

1.7.1 Protective Ground (Earth) connection

The ground loop impedance must conform to the requirements of local safety regulations. The drive must be grounded by a connection capable of carrying the prospective fault current until the protective device (fuse or circuit breaker) disconnects the supply. The ground connections must be inspected and tested at appropriate intervals.

1.7.2 Fuses

The supply to the drive must be installed with suitable protection against overload and short-circuits. The tables in the relevant documentation show recommended fuse ratings. Failure to observe these installation instructions could result in fire.

1.7.3 Cables

The cable sizes in the relevant documentation are only a guide. The mounting and grouping of cables affects their current-carrying capacity, in some cases smaller cables may be acceptable but in other cases a larger cable is required to avoid excessive temperature or voltage drop. Refer to local wiring regulations for the correct size of cables. Failure to observe these installation instructions could result in fire.

1.7.4 Terminal connections and torque settings

Loose power connections can be a fire risk. Always ensure that terminals are tightened to the specified torques. Refer to the tables in the relevant documentation.



WARNING - Fire Risk

Braking resistors operate at very high temperatures for short periods. The following precautions are essential to avoid the risk of fire in the event of unexpectedly high braking energy or loss of control of the braking circuit.

- Locate the braking resistor so that inadvertent personal contact with hot surfaces is not possible.
- Do not mount braking resistors on a combustible surface.
- Provide adequate ventilation.
- Mount the braking resistor or reactor in the orientation specified in the data sheet.
- The metal case of the braking resistor must be grounded.
- Use cable with insulation that is capable of withstanding high temperatures.
- Provide independent protection against a loss of control by the braking control system in the drive - refer to the relevant documentation.

1.7.5 High voltage insulation (flash) testing

High voltage insulation (flash) testing should not be carried out on the drive.

1.7.6 ELV terminals

The control terminals are only single insulated from the mains supply, and hence must be prevented from human contact by an additional isolation barrier, for example a terminal cover.

1.7.7 SELV terminals

Drive terminals that are SELV can be safely connected to other SELV equipment.

ELV terminals require an additional insulation barrier between them and other SELV equipment if it is unacceptable to compromise the SELV classification of the SELV equipment.

1.7.8 Products connected by plug and socket

An electric shock hazard exists if the drive is supplied via a plug and socket. When unplugged, the pins of the plug may carry a potentially lethal voltage until the internal capacitors have discharged. This can take up to 10 minutes.

It is recommended that a shrouded plug is used that complies with IEC 60309. If the use of a shrouded plug is not possible, then to avoid any possibility of electric shock from the pins, a means must be provided for automatically isolating the plug from the drive (for example a latching relay).

1.8 Setting up, commissioning and maintenance



It is essential that changes to the drive settings are given careful consideration.

Depending on the application, a change could have an impact on safety.

Appropriate precautions must be taken against inadvertent changes or tampering.

Some specific settings which require particular care are listed below. This is not an exclusive list. Other settings may have an impact on safety in specific applications.

1.8.1 Lifting and handling

Many of the drives weigh in excess of 15 kg (33 lb). Use appropriate safeguards when lifting these models. A full list of drive weights can be found in the installation instructions.

1.8.2 Output circuit and motor protection

The Motor Rated Current parameter must be set correctly to avoid a risk of overheating and fire in the event of motor overload. In some applications motor temperature protection may also be required.

1.8.3 STOP, Enable and Safe Torque Off functions (where applicable)

These functions do not remove dangerous voltages from the equipment or any external option unit, nor do they isolate the motor from dangerous voltages.

Automatic start

Some parameter settings may cause the motor to start unexpectedly.

Restore default parameter set

Depending on the application, this may cause unpredictable or hazardous operation.

1.9 Safety of machinery, safety-critical applications

Within the European Union all machinery in which this product is used must comply with Machinery Directive 2006/42/EC.

The design of safety-related control systems must only be done by personnel with the required training and experience. The Safe Torque Off function will only ensure the safety of a machine if it is correctly incorporated into a complete safety system. The system must be subject to a risk assessment to confirm that the residual risk of an unsafe event is at an acceptable level for the application.

1.10 Electromagnetic compatibility (EMC)

The product is designed to comply with international standards in a typical installation. Installation instructions are provided in the *Power Installation Guide* and EMC data sheet. If the installation is poorly designed or other equipment does not comply with international standards for EMC, the product might cause or suffer from disturbance due to electromagnetic interaction with other equipment. It is the responsibility of the installer to ensure that the equipment or system into which the product is incorporated complies with the relevant EMC legislation in the country of use.

Within the European Union, equipment into which this product is incorporated must comply with the Electromagnetic Compatibility Directive 2014/30/EU.

1.11 Copyright

The contents of this publication are believed to be correct at the time of printing. In the interests of a commitment to a policy of continuous development and improvement, the manufacturer reserves the right to change the specification of the product or its performance, or the contents of the guide, without notice.

All rights reserved. No parts of this publication may be reproduced or transmitted in any form by any means, electrical or mechanical including photocopying, recording or by an information storage or retrieval system, without permission in writing from the publisher.

2 Introduction

2.1 Products covered by this User Guide

This User Guide covers the SI-POWERLINK option module.

The SI-POWERLINK is an option module that provides POWERLINK connectivity and can be installed on the following drives:

- Commander C200 (sizes 2 and above)
- Commander C300 (sizes 2 and above)
- Unidrive M400 (sizes 2 and above)
- Unidrive M600
- Unidrive M700 / M701 / M702
- Digitax HD M750 / M751 / M753

2.2 Firmware Statement

This product is supplied with the latest firmware version. When retro-fitting to an existing system, all firmware versions should be verified to confirm the same functionality as products of the same type already present. This also applies to products returned from a Control Techniques's Service Centre or Repair Centre. If there is any doubt please contact the supplier of the product.

The firmware version of the product can be identified by looking at Pr **MM.002** where MM is the relevant menu number for the module slot being used.

2.3 What is POWERLINK?

POWERLINK is an open high performance Ethernet-based fieldbus system that overcomes the system limitations of some other Ethernet solutions. POWERLINK uses a mixture of timeslot and polling procedures to achieve isochronous data transfer. In order to ensure co-ordination, a PLC or an Industrial PC is designated to be the so-called Managing Node (MN). This manager enforces the cycle timing that serves to synchronize all devices and controls cyclical data communication. All other devices operate as Controlled Nodes (CN). In the course of one clock cycle, the MN sends so-called "Poll Requests" to one CN after another in a fixed sequence. Every CN replies immediately to this request with a "Poll Response" on which all other nodes can listen in.

A POWERLINK cycle consists of three periods. During the "Start Period," the MN sends a "Start of Cycle" (SoC) frame to all CNs to synchronize the devices. Jitter amounts to about 20 nanoseconds. Cyclic isochronous data exchange takes place during the second period ("Cyclic Period").

Multiplexing allows for optimized bandwidth use in this phase. The third period marks the start of the asynchronous phase, which enables the transfer of large, non-time-critical data packets. Such data, e.g. user data or TCP/IP frames, is scattered between the asynchronous phases of several cycles. POWERLINK distinguishes between real-time and non-real-time domains. Since data transfer in the asynchronous period supports standard IP frames, routers separate data safely and transparently from the real-time domains. POWERLINK is very well suited to all sorts of automation applications including I/O, Motion Control, robotics tasks, PLC-to-PLC communication and visualization.

NOTE POWERLINK uses the term **Managing Node** abbreviated to **MN** to indicate a "Master" device such as a PLC, and the term **Controlled Device** abbreviated to **CN** to indicate a "Slave" device such as SI-POWERLINK.

2.4 About SI-POWERLINK

SI-POWERLINK is an option module that enables the Control Techniques Unidrive M, Digitax HD and Commander C range of variable speed drives to be connected to a POWERLINK network as a Controlled Node (slave). It can be used in a variety of applications, from those requiring accurate synchronization and precise motion control, to those where ease of use and open loop control are appropriate.

2.5 Features

- Standard RJ45 with support for shielded twisted pair, half-duplex / full-duplex and 10 Mbs / 100 Mbs connectivity
- Dual 100 Mbps POWERLINK interfaces for use in line topologies i.e. daisy chaining
- Supports the Unidrive M, Digitax HD and Commander C drives range
- Control loop synchronization
- Control cycle times down to 500 μ s
- CANopen for POWERLINK which includes:
 - Support of CANopen CiA402
 - SDO access to all profile objects and drive parameters
 - Cyclic synchronous position mode
 - Cyclic synchronous velocity mode
 - Cyclic synchronous torque mode
 - vl velocity mode
 - Homing mode

2.6 Option module identification

Figure 2-1 SI-POWERLINK

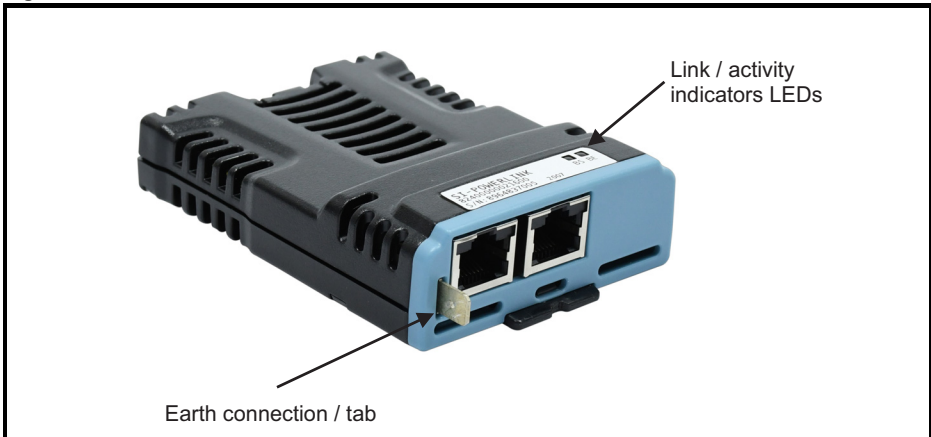

The SI-POWERLINK module can be identified by:

- The label located on the underside of the option module.
- The colour coding across the front of the SI-POWERLINK (pale blue).

Figure 2-2 SI-POWERLINK labels

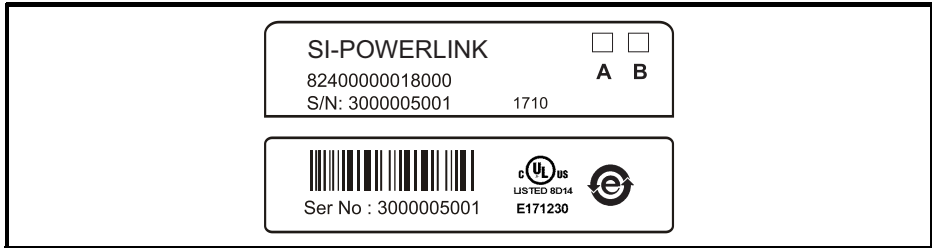

2.6.1 Date code format

The date code is four numbers. The first two numbers indicate the year and the remaining numbers indicate the week of the year in which the drive was built.

Example:

A date code of **1710** would correspond to week 10 of year 2017.

2.7 Conventions used in this guide

The configuration of the host drive and option module is done using menus and parameters. A menu is a logical collection of parameters that have similar functionality.

In the case of an option module, the option module set-up parameters in menu 0 will appear in drive menu 15, 16 or 17 depending on which slot the module is installed in.

The setting of the Option Slot Identifiers (Pr **11.056**) may change the slot numbering from those described above.

NOTE For C200, C300 and M400 drives, the option module set-up parameters will appear in menu 15.

The method used to determine the menu or parameter is as follows:

- Pr **S.mm.ppp** - Where **S** signifies the option module slot number and **mm.ppp** signifies the menu and parameter number respectively.
If the option module slot number is not specified then the parameter reference will be a drive parameter.
- Pr **MM.ppp** - Where **MM** signifies the menu allocated to the option module setup menu and **ppp** signifies the parameter number within the set-up menu.
- Pr **mm.000** - Signifies parameter number 000 in any drive menu.

3 Mechanical installation



Before installing or removing an option module in any drive, ensure the AC supply has been disconnected for at least 10 minutes and refer to Chapter 1 *Safety information* on page 6. If using a DC bus supply ensure this is fully discharged before working on any drive or option module.

3.1 General installation

The installation of an option module is illustrated in Figure 3-1.

Figure 3-1 Installation of an SI option module on Commander C200, C300 and Unidrive M400 (sizes 2 to 4)

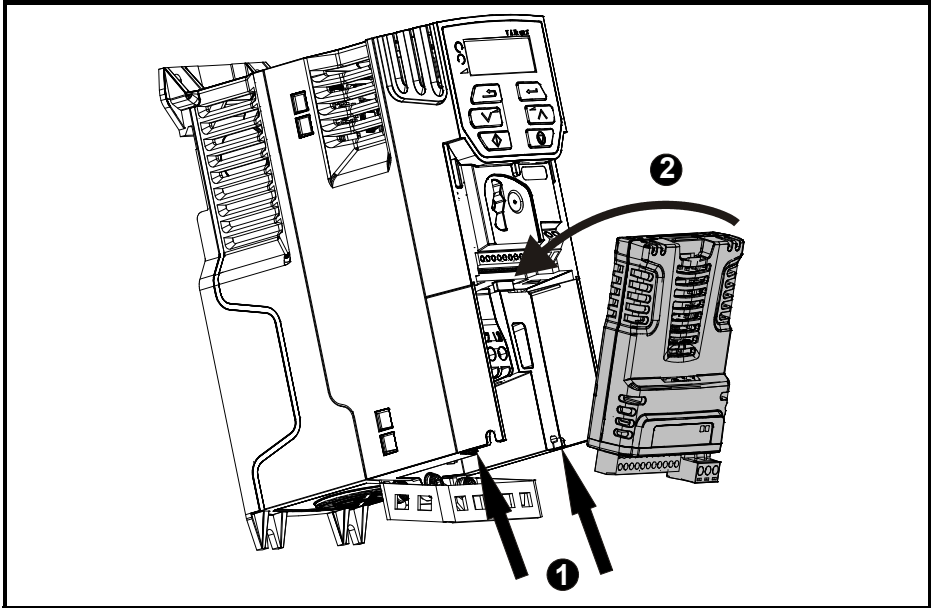

- With the option module tilted slightly backwards, align and locate the two holes in the rear of the option module onto the two tabs (1) on the drive.
- Place the option module onto the drive as shown in (2) until the module clicks into place. The terminal cover on the drive holds the option module in place, so this must be put back on.

NOTE Option modules can only be installed on drives that have the option module slot functionality.

Safety information
Introduction
Mechanical installation
Electrical installation
Getting started
Supported Objects
PDO, SDO & POWERLINK Modes
Object descriptions
Drive profile modes
Parameter descriptions
Diagnostics
Glossary of terms
Index

Figure 3-1 Installation of an SI option module on Commander C200, C300 and Unidrive M400
(size 5 to 9)

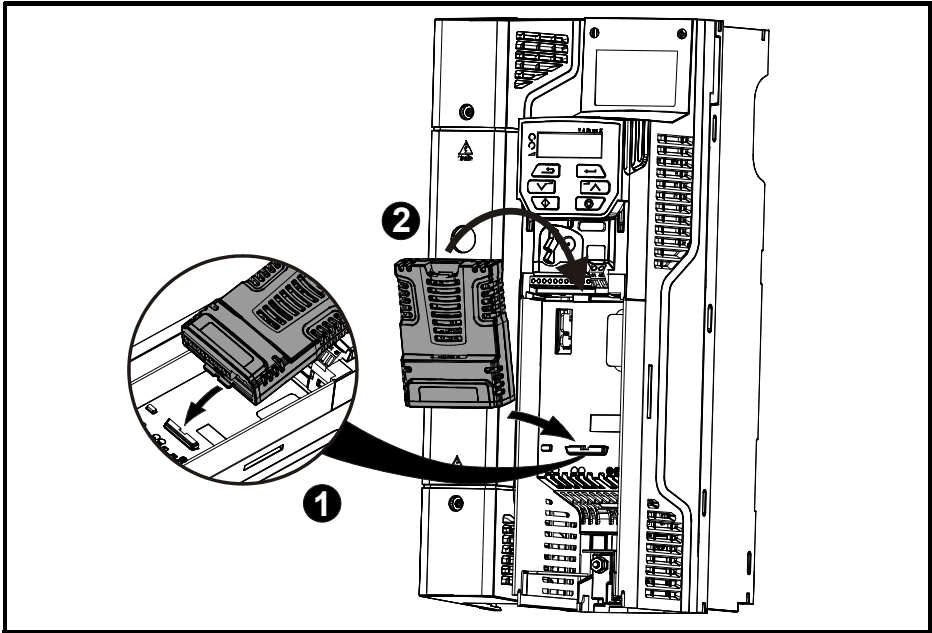

- Place the option module onto the drive as shown in (2) until the module clicks into place. The terminal cover on the drive holds the option module in place, so this must be put back on.

Figure 3-2 Installation of an SI option module on Unidrive M600 to M702

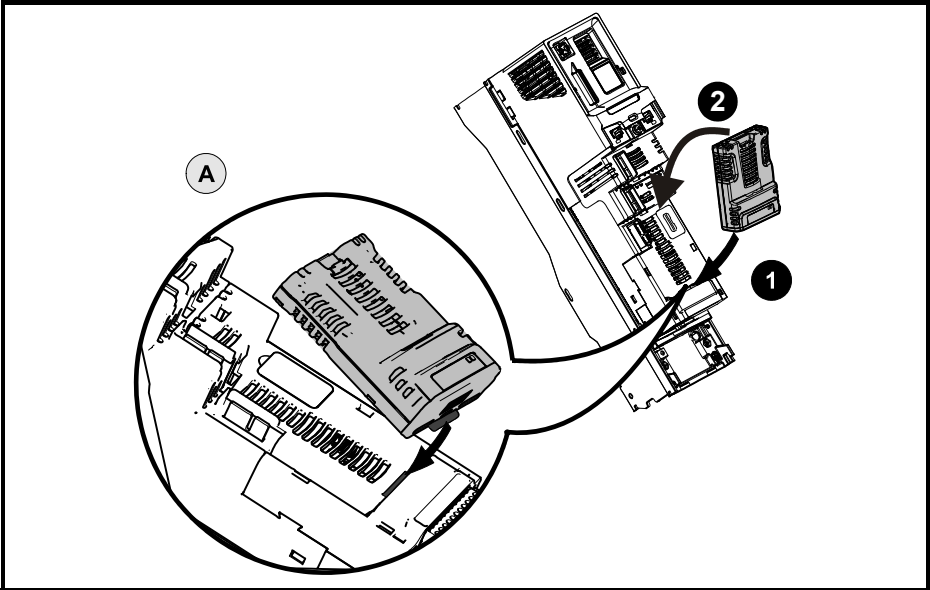

- Move the option module in direction shown (1/2).
- Align and insert the option module tab in to the slot provided, this is highlighted in the detailed view (A).
- Press down on the option module until it clicks into place.

NOTE Option module slots must be used in the following order: Slot 3 (lower), Slot 2 (middle) and then Slot 1(upper).

Figure 3-3 Installation of an SI option module on Digitax HD M750, M751 and M753

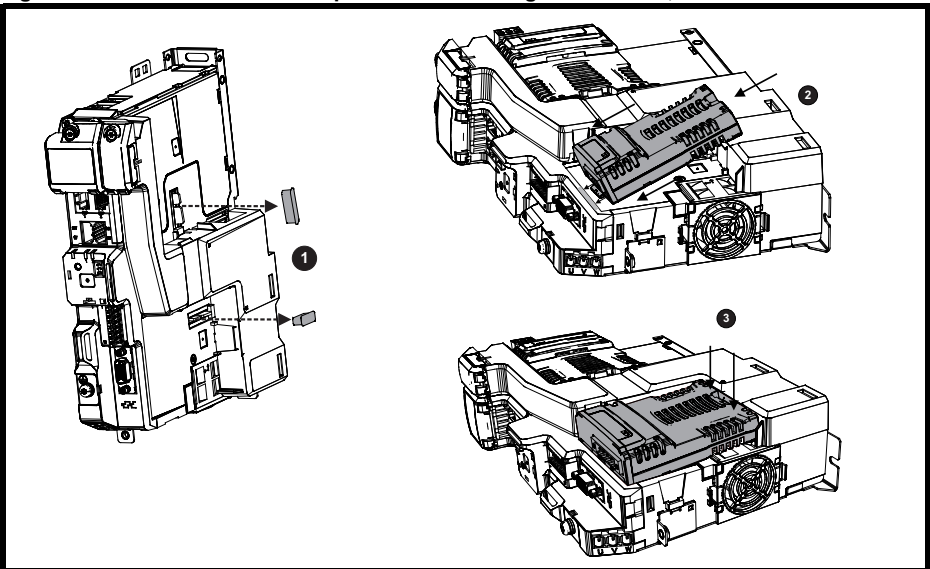

Safety Information
Introduction
Mechanical Installation
Electrical Installation
Getting started
Supported Objects
PDO, SDO & POWERLINK Modes
Object descriptions
Drive profile modes
Parameter descriptions
Diagnostics
Glossary of terms
Index

4 Electrical installation

4.1 SI-POWERLINK module information

4.1.1 Bus media

The SI-POWERLINK option module incorporates two 100 BASE-TX RJ45 interfaces.

4.1.2 Cabling considerations

To ensure long-term reliability it is recommended that any cables used to connect a system together be tested using a suitable Ethernet cable tester, this is of particular importance when cables are constructed on site.

4.1.3 Cabling and connections / pin assignments

Cables should be shielded and as a minimum, meet TIA Cat 5e requirements.

Please refer to IEC 61918 and IEC 61784-5-13.

SI-POWERLINK supports Auto-MDIX (automatic medium-dependent interface crossover). However, the EPSG recommends that the pin assignment shall be that of a crossover cable.

The pin assignment of a crossover cable is defined as:

- Tx+ to Rx+
- Tx- to Rx-
- Rx+ to Tx+
- Rx- to Tx-

See Figure 4-1 for recommended RJ45 to RJ45 pin assignment.

Figure 4-1 Recommended RJ45 to RJ45 pin assignment

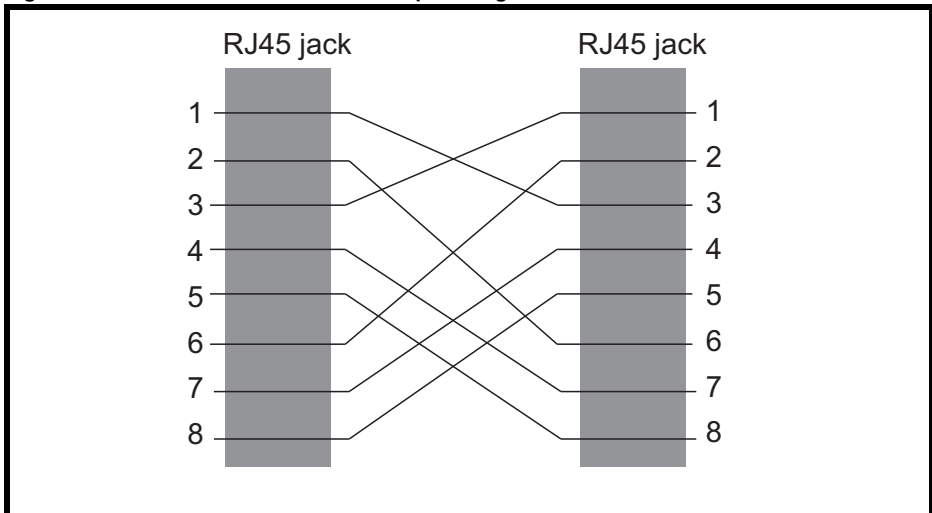
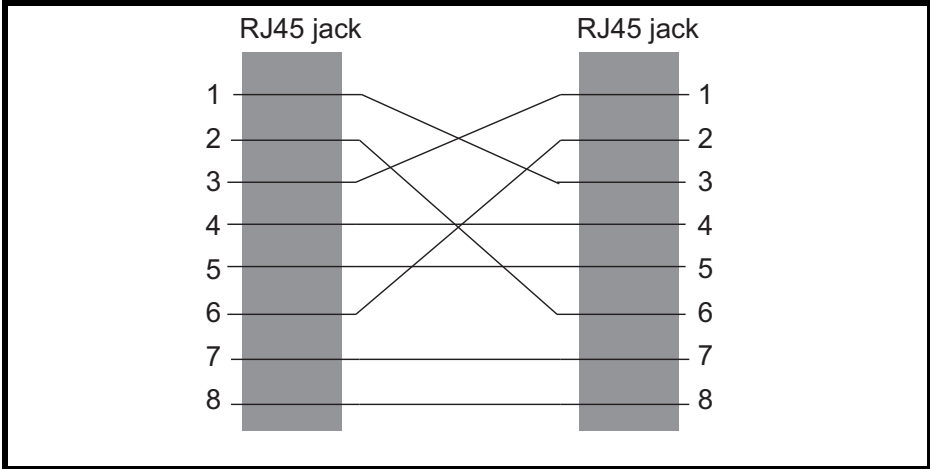

Figure 4-2 NOT Recommended RJ45 to RJ45 pin assignment



NOTE Cabling issues are the single biggest cause of network downtime. Ensure cabling is correctly routed, wiring is correct, connectors are correctly installed and any switches or routers used are rated for industrial use. Office grade Ethernet equipment does not generally offer the same degree of noise immunity as equipment intended for industrial use.

4.1.4 Maximum network length

The maximum cable length (100 meters) predefined by Ethernet 100 Base-TX shall apply. This means that the maximum cable length which can be used between one SI-POWERLINK port and another 100BASE-TX port is 100 m.

NOTE The POWERLINK system designer must consider the impact that the selected network structure will have on performance.

4.1.5 Ethernet Infrastructure

Any standard Ethernet infrastructure including managed switches, that are inserted within the POWERLINK network will cause delays that will impact determinism and synchronization.

Safety information
Introduction
Mechanical installation
Electrical installation
Getting started
Supported Objects
PDO, SDO & POWERLINK Modes
Object descriptions
Drive profile modes
Parameter descriptions
Diagnostics
Glossary of terms
Index

4.2 SI-POWERLINK terminal descriptions

The SI-POWERLINK module has two RJ45 Ethernet ports for the POWERLINK network.

Figure 4-3 SI-POWERLINK connections

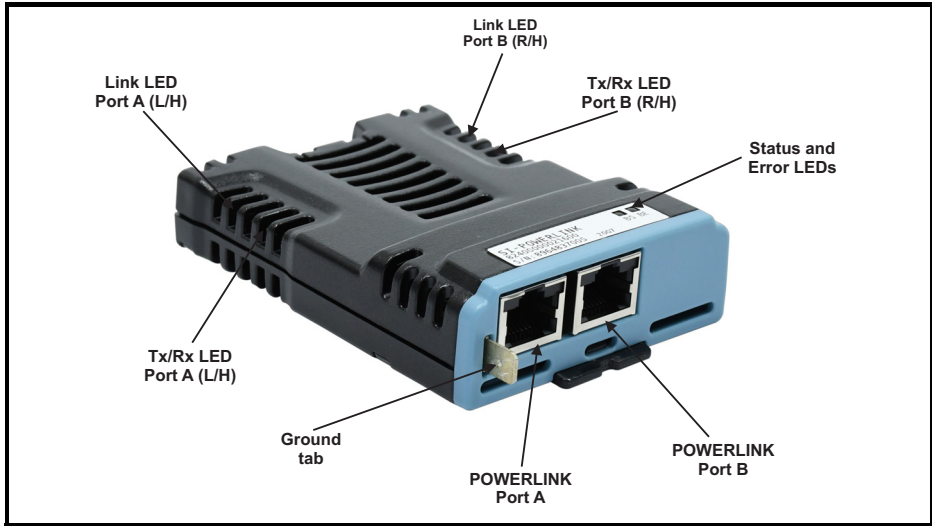

Table 4-1 POWERLINK terminal descriptions

Pin	A - IN	Pin	B - OUT
1	Receive +	1	Receive +
2	Receive -	2	Receive -
3	Transmit +	3	Transmit +
4	Not used	4	Not used
5	Not used	5	Not used
6	Transmit -	6	Transmit -
7	Not used	7	Not used
8	Not used	8	Not used

NOTE The Transmit and Receive connections are transposed (in accordance with ESPG recommendations) to that of other Control Technique Ethernet based products. SI-POWERLINK however supports Auto-MDIX. See section 4.1.3 for further details..

4.3 Module grounding and EMC

SI-POWERLINK is supplied with a grounding tab on the module that should be connected to the closest possible grounding point using the minimum length of cable. This will greatly improve the noise immunity of the module.

4.4 Network topology

Control Techniques recommend implementing daisy chaining on POWERLINK networks (see Figure 4-4).

Figure 4-4 SI-POWERLINK daisy chain network topology

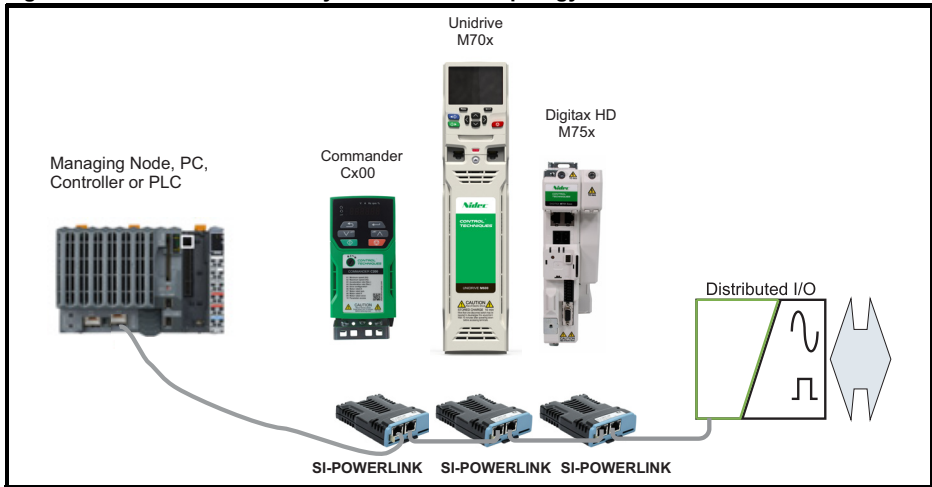

4.5 Minimum node-to-node cable length

There is no minimum length of cable recommended in the Ethernet standards. To avoid possible problems it is recommended that you allow sufficient cable length to ensure good bend radii on cables and avoid unnecessary strain on connectors.

Safety information
Introduction
Mechanical installation
Electrical installation
Getting started
Supported Objects
PDO, SDO & POWERLINK Modes
Object descriptions
Drive profile modes
Parameter descriptions
Diagnostics
Glossary of terms
Index

4.6 Indicator LEDs

Figure 4-3 shows the locations of the LEDs

The LED on the left bottom is the Status/BS LED, and the LED on the right bottom is the Error/BE LED.

For each port there are two additional LEDs indicating Tx/Rx and Link/L. Both sets are visible through the ventilation slots on the module. (These may be obscured if the SI-POWERLINK is fitted to slot 2 or slot 3 of a Unidrive M600/M70x and further option modules are also fitted. Or if fitted to an M75x).

Table 4-2 Distinguishing LED states

Table 4-2 shows how indicator states are displayed

LED on	Constantly on
LED off	Constantly off
LED flickering	Equal on and off times with a frequency of approximately 10 Hz: on for approximately 50 ms and off for approximately 50 ms.
LED blinking	Equal on and off times with a frequency of approximately 2.5 Hz: on for approximately 200 ms followed by off for approximately 200 ms
LED single flash	One short flash (approximately 200 ms). The sequence is finished by a long off phase (approximately 1000 ms).
LED double flash	A sequence of two short flashes (approximately 200 ms), separated by an off phase (approximately 200 ms). The sequence is finished by a long off phase (approximately 1000 ms).
LED triple flash	A sequence of three short flashes (approximately 200 ms), separated by an off phase (approximately 200 ms). The sequence is finished by a long off phase (approximately 1000 ms)

4.7 Status and Error LEDs

4.7.1 Status (BS) LED

The Status LED is controlled by the NMT state machine's states.

STATUS LED	State
LED Off	NMT_CS_OFF, NMT_CS_INITIALISATION, NMT_CS_NOT_ACTIVE / NMT_MS_NOT_ACTIVE
LED flickering	NMT_CS_BASIC_ETHERNET
LED single flash	NMT_CS_PRE_OPERATIONAL_1 / NMT_MS_PRE_OPERATIONAL_1
LED double flash	NMT_CS_PRE_OPERATIONAL_2 / NMT_MS_PRE_OPERATIONAL_2
LED triple flash	NMT_CS_READY_TO_OPERATE / NMT_MS_READY_TO_OPERATE
LED on	NMT_CS_OPERATIONAL / NMT_MS_OPERATIONAL
LED blinking	NMT_CS_STOPPED

4.7.2 Error (BE) LED

The Error LED is controlled by the NMT state machine's transitions. The Error LED will illuminate continually red if an error is detected.

4.8 Tx/Rx and Link LED.

4.8.1 Tx / Tx LED

The Tx/Rx LED flashes yellow when data is transmitted or received.

4.8.2 Link (L) LED

The Link LED illuminates continually green when an Ethernet link is established.

5 Getting started

5.1 Quick start guide

This section is intended to provide a basic guide for setting up SI-POWERLINK with a B&R PLC as the managing Node. It will cover the basic steps required to get non-cyclic and cyclic data communicating using the CANopen protocol on the SI-POWERLINK module.

NOTE It is strongly recommended that the latest firmware be used where possible to ensure that all features are supported.

Details are provided for a B&R PLC as the master (managing node) only. Generic support is available through your supplier or local Control Techniques Drive Centre.

5.1.1 SI-POWERLINK XDD File

Control Techniques provides POWERLINK XDD descriptor files. These files provide the Managing Node with information about the SI-POWERLINK module and drive configuration to aid with its configuration. These files can be downloaded from the Control Techniques website or from your local Control Techniques Drive Centre or supplier.

5.2 Configuring the SI-POWERLINK module for communications

Unlike some other Control Techniques fieldbus communication protocols, CANopen for POWERLINK does not require that many module parameters be changed in order to achieve communications. The baud rate of the network is fixed.

NOTE The user is required to manually set the node address in the module using parameter SS.00.031. The default value is node 1.

To check that the Ethernet cable connected to the SI-POWERLINK module on the drive is connected correctly, look at the right hand Link (L) LED on the front of the SI-POWERLINK module, it should glow green when an Ethernet link is established. See section 4-7 *Status and Error LEDs* for details of states.

It is recommended that the user makes themselves familiar with B&R's hardware and development platform Automation Studio, the following examples assume the user has at least basic familiarity with Automation Studio.

In the following example a B&R X20 CP 1585 PLC is connected to an SI-POWERLINK module that is fitted to an M700 drive, power is supplied to the drive and B&R PLC. An Ethernet cable is connected between the IF2 port of the PLC and a PC running B&R's Automation Studio, and a suitable Ethernet cable between the IF3 port of the PLC and the left hand port of the SI-POWERLINK module.

The following examples are provided in good faith however, Control Techniques cannot offer direct support for B&R or other manufacturers' products. Generic support for the SI-POWERLINK module is available through your supplier or local Control Techniques Drive Centre. For support of other manufacturers' products, please contact the relevant third party support channels.

Safety Information
Introduction
Mechanical Installation
Electrical Installation
Getting started
Supported Objects
PDO, SDO & POWERLINK Modes
Object descriptions
Drive profile modes
Parameter descriptions
Diagnostics
Glossary of terms
Index

5.3 Adding the XDD descriptor file to Automations Studio

Create a new project within Automation Studio. Select *Tools* from the toolbar and then select *Import Fieldbus Device*. Browse to the location of the XDD file and click on the required file, in this case the *Unidrive_M700_RFC_S.xdd*. Follow the instructions within Automation Studio to complete installation of the file.

5.4 Creating the hardware configuration within Automation Studio

It is assumed that a new project has been created with the correct PLC type, and that the default node address of 1 is used within the project, and the default of 1 is configured in the SI-POWERLINK module (SS.00.031).

See figure 5-1. Open the Logical View, here you should see an image of the PLC. In the *Toolbox-Hardware Catalog* search bar, type in Unidrive. Automation Studio will filter available devices and display them in the lower part of the *Toolbox-Hardware Catalog*. Click on the Unidrive M700 RFC_S device and drag it into the System Designer window.

Click on the right port of the PLC (IF3) and draw a line to the top port of the Unidrive M700.

Figure 5-1

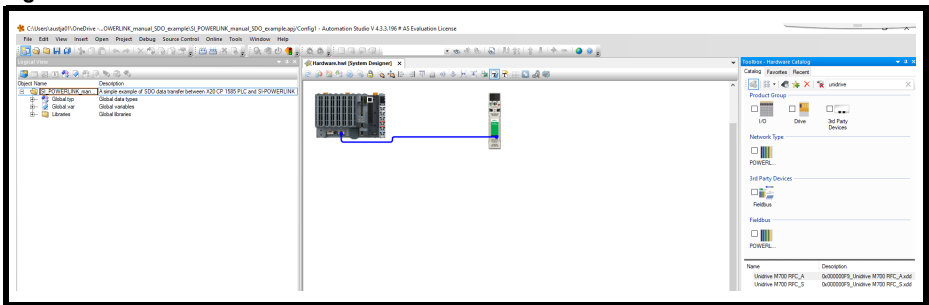

5.5 Non-cyclic data - SDO communications example

SDO communications are based on the client/server principle. An SDO client establishes a connection to an SDO server and issues a specific command (read or write from/to an object). This connection is unicast, and allows access to objects of a remote node, and is not deterministic (i.e. there is no guarantee on how long the response takes after sending a request). In POWERLINK, SDO communication takes place in the asynchronous phase.

This example will demonstrate reading a drive's parameter using SDO communications.

Click on the *Logical View* window and then from the *Toolbox-Object Catalog* click on *ST Program All In One*.

Click on the *Toolbox-Object Catalog* and select the AsePL library from the B&R Libraries folder. This library supports SDO data objects for POWERLINK devices.

Add the variables and Function Block instance shown in Figure 5-2. Note, the variable of type string has a value of 'IF3' to indicate the POWERLINK port on the PLC. When adding the instance of the Function Block *Eps/SDORead* the Show only local check box should be un-checked, see Figure 5-3.

Figure 5-2

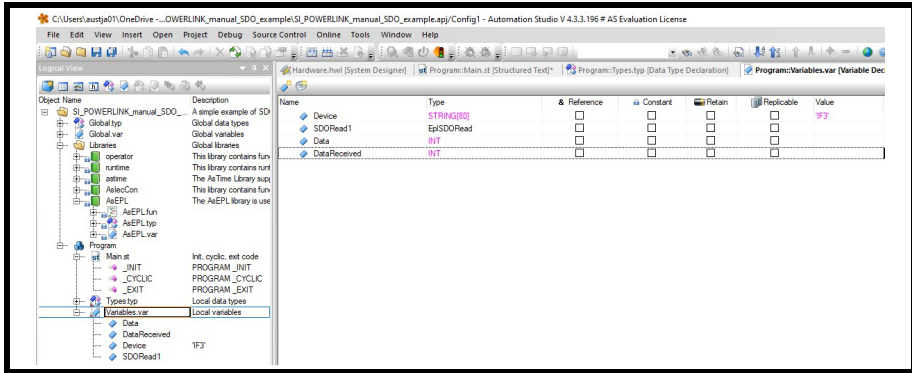
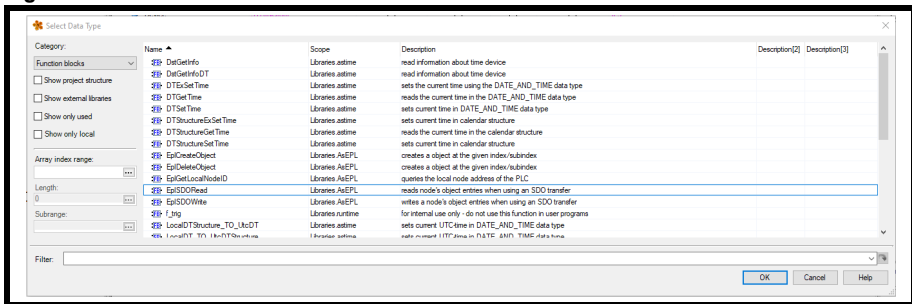

Figure 5-3



Add the following program code to main.st, as shown in Figure 5-4:

PROGRAM_INIT

```
SDORead1.dataLen := 2; //Data length, 2 bytes for 16-bit parameter
SDORead1.pDevice := ADR(Device); //POWERLINK interface on MN (PLC) '1F3'
SDORead1.pData := ADR(Data); //Data to be read into here
SDORead1.node := 1; //Node address of CN (SI-POWERLINK,default value = 1)
SDORead1.index := 16#2014; //Menu 20
SDORead1.subindex := 1; //Parameter 1
```

END_PROGRAM

PROGRAM_CYCLIC

```
SDORead1(enable := TRUE);
IF SDORead1.status <> ERR_FUB_BUSY THEN
    SDORead1(enable := FALSE);
END_IF
```

```
DataReceived := Data;
```

END_PROGRAM

Figure 5-4

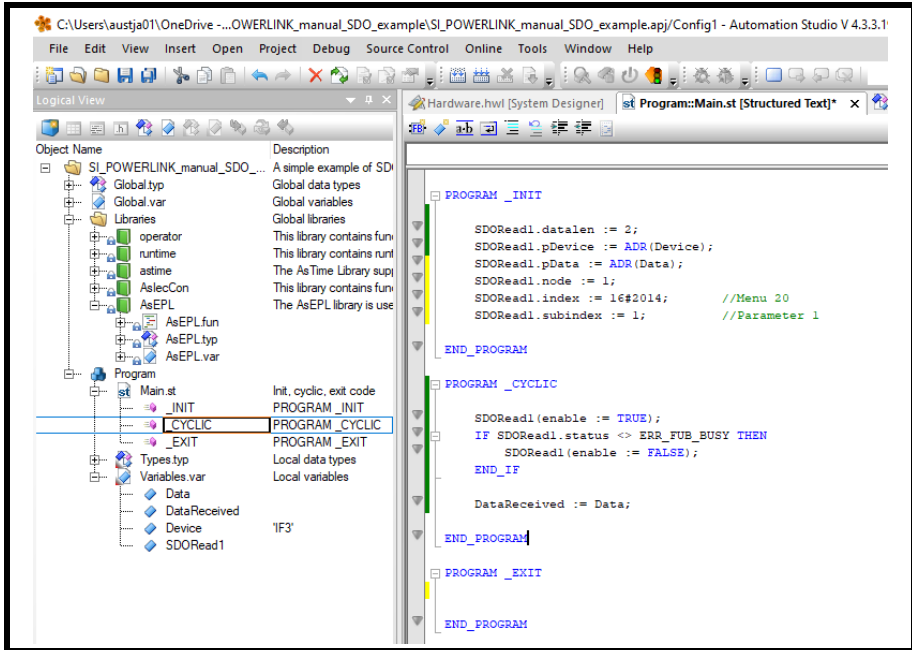

In the example project change the Mode for Ethernet port ETH from "Get IP address from DHCP Server" to "enter IP address manually" then enter the IP address and Subnet mask that will be used by the PLC when the project is downloaded. (This is not necessarily the address already stored in the physical PLC, but rather the address that will be stored and will become active once the project is downloaded). Figure 5-5.

Figure 5-5

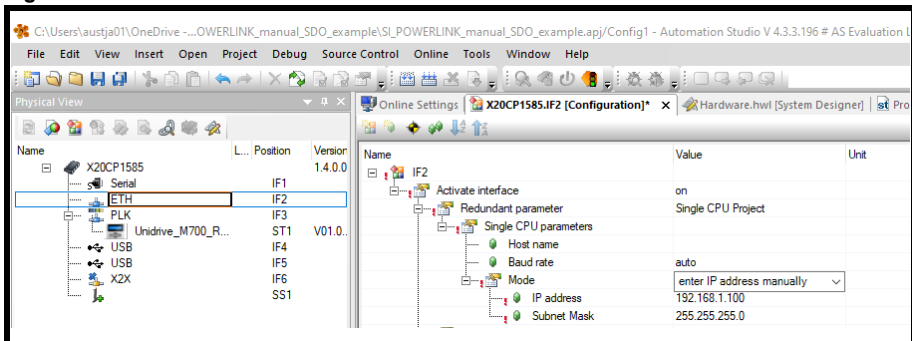

If an IP address has not been previously configured within the B&R PLC then refer to the B&R documentation within Automation Studio.

From the toolbar Click *Online* then *Settings...* Press the online button situated on the top left of the *Online Settings* window, as shown in Figure 5-6. If required click the *Refresh* icon to re-scan for target PLCs. Select the PLC and click the Connect icon. (This is the IP address already stored in the physical PLC).

Figure 5-6

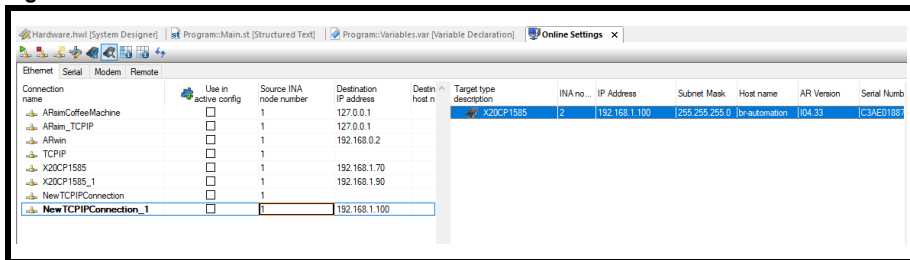

From the main toolbar select *Project>Project Installation>Transfer to Target*. Follow the on screen instructions within Automation Studio to complete the transfer.

Once the project is transferred and running, view the main.st program and click the monitor button on the toolbar. As parameter 20.001 is adjusted in the drive, while hovering the mouse over *DataReceived* the value of parameter 20.001 will be shown.

Figure 5-7

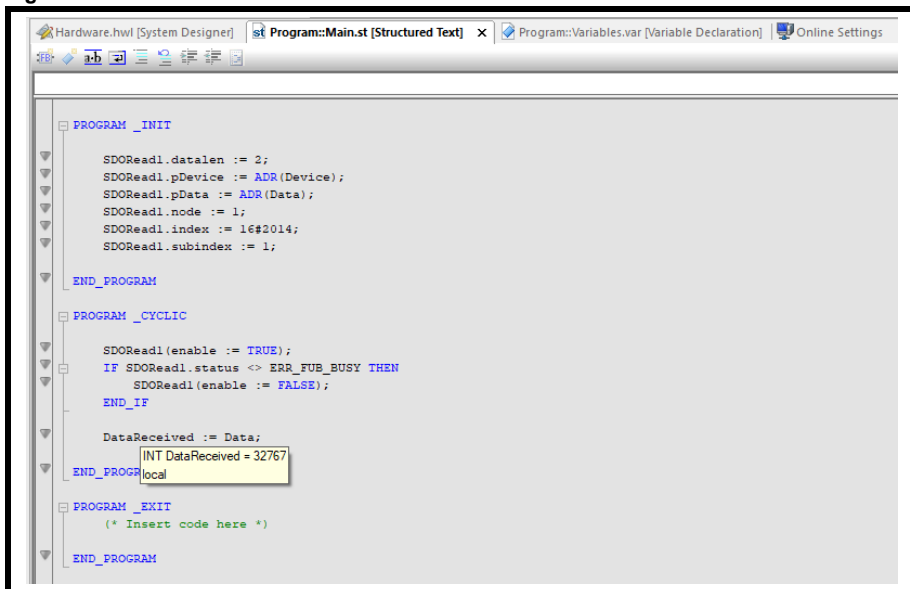

5.6 Cyclic data - PDO communications example

It is assumed that the Non-cyclic data - SDO communications example in Section 5.5 has firstly been read, the correct XDD descriptor file has been loaded into Automation studio for the Unidrive M700 and the hardware and program have been created in Automation Studio before progressing to this current example.

In this example data will be written to the PLC cyclically using PDOs. In POWERLINK Cyclic data exchange takes place in the Isochronous phase. ("Equal - time". Data is transferred continuously and at a steady rate in close timing).

Modifying the SDO example project from section 5.4, we will add a Cyclic parameter. Right click on the drive in the Hardware.hw[System designer] window and select configuration, for Parameter 20.002, select the Write attribute in the Value column. See Figure 5-8.

Figure 5-8

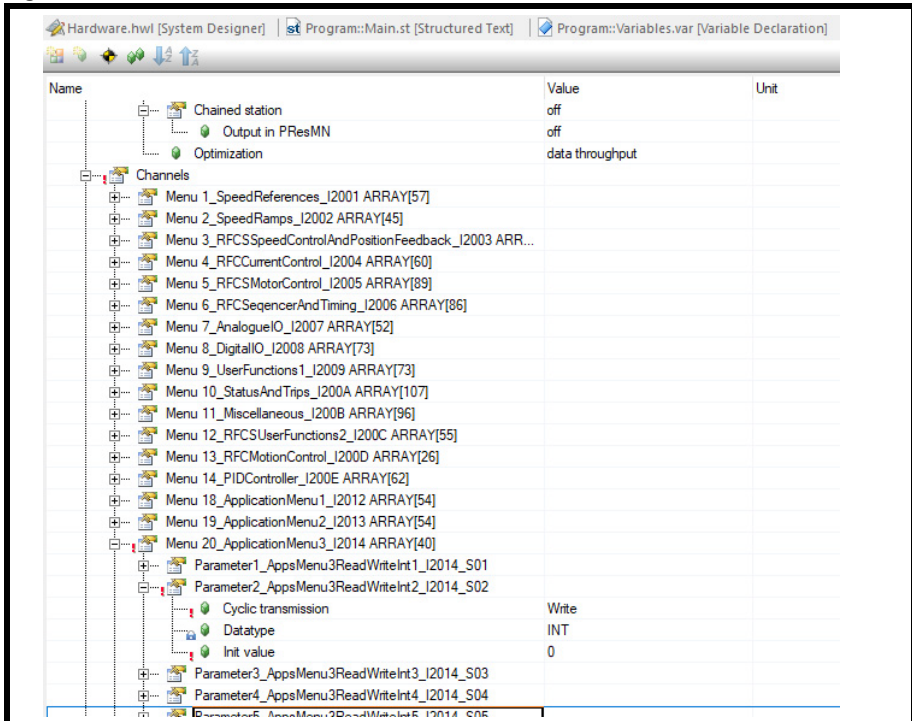

Modify the program from Section 5.6 to include the following shown in Figure 5-9 and Figure 5-10.

Figure 5-9

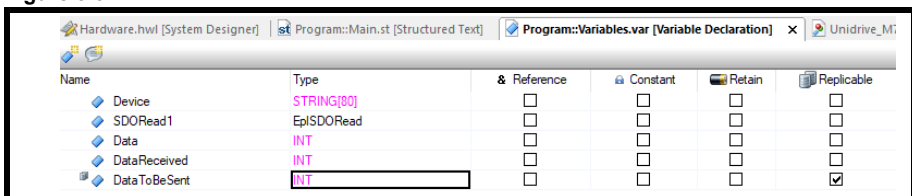
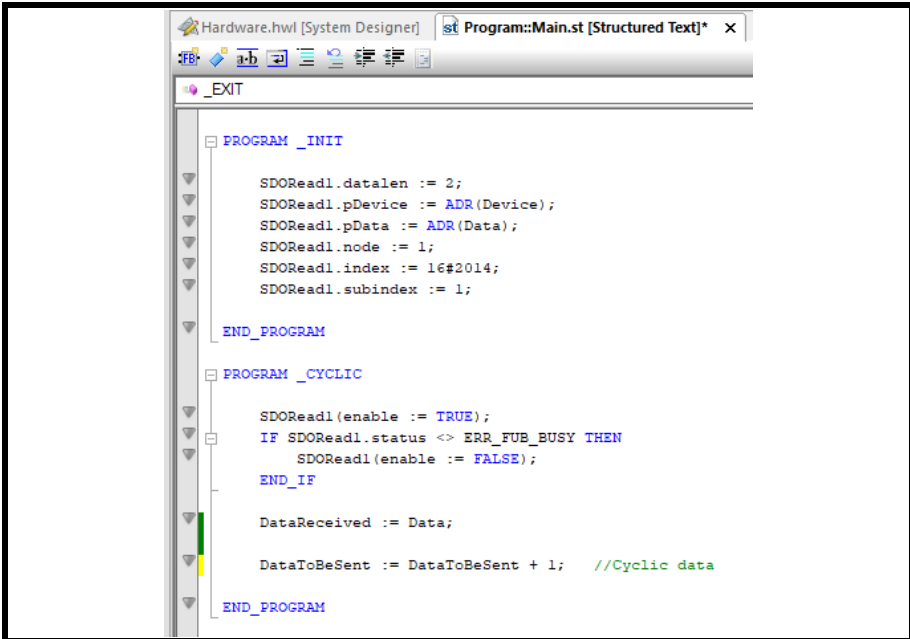
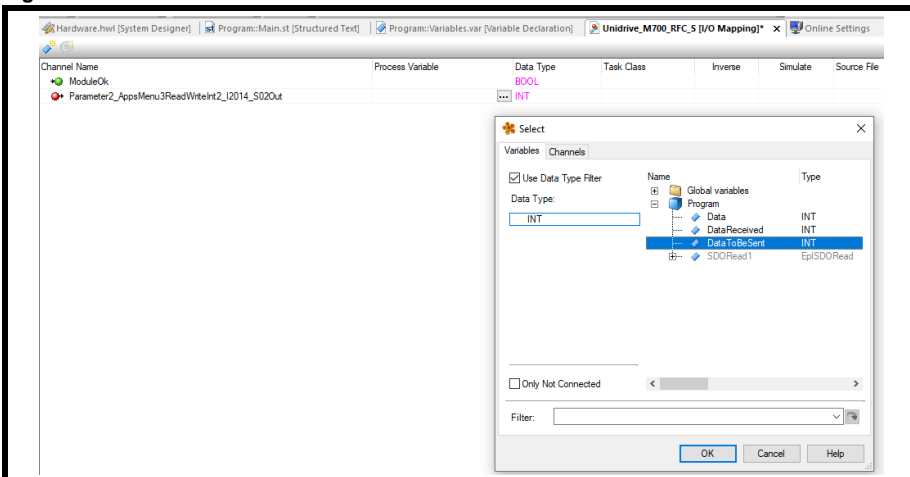

Figure 5-10



Now Build the Configuration (F7). Right click on the drive in the Hardware.hw1[System designer] window and select I/O Mapping. Select the variable DataToBeSent as shown in Figure 5-11.

Figure 5-11



From the main toolbar select *Project>Project Installation>Transfer to Target*. Follow the on screen instructions within Automation Studio to complete the transfer.

Once the project is transferred and running, view the main.st program and click the monitor button on the toolbar. DataToBeSent should be incrementing, as should parameter 20.002 on the drive's keypad display.

6 Supported Objects

6.1 Supported objects

Table 6-1 lists the objects currently supported by SI-POWERLINK

Table 6-1 SI-POWERLINK Object Dictionary

Object Ref. (0x)	Description	Data Type		Access	Profile				
		Sub-index	Type		VL Velocity	Homing	CST	CSP	CSV
1000	Device type	0	UDINT	RO	Y	Y	Y	Y	Y
1001	Error register	0	USINT	RO	Y	Y	Y	Y	Y
1018	Identity object (Number of last sub-index)	0	USINT	RO	Y	Y	Y	Y	Y
	Identity object (Vendor ID)	1	UDINT	RO	Y	Y	Y	Y	Y
	Identity object (Product Code)	2	UDINT	RO	Y	Y	Y	Y	Y
	Identity object (Software Version)	3	UDINT	RO	Y	Y	Y	Y	Y
	(Reserved)	4	UDINT	RO	Y	Y	Y	Y	Y
1600	Receive PDO mapping 1 (Number of objects)	0	USINT	RW	Y	Y	Y	Y	Y
	Receive PDO mapping 1 (Mapped object 1 to si0)	1 to si0	UDINT	RW	Y	Y	Y	Y	Y
1601	Receive PDO mapping 2 (Number of objects)	0	USINT	RW	Y	Y	Y	Y	Y
	Receive PDO mapping 2 (Mapped object 1 to si0)	1 to si0	UDINT	RW	Y	Y	Y	Y	Y
1602	Receive PDO mapping 3 (Number of objects)	0	USINT	RW	Y	Y	Y	Y	Y
	Receive PDO mapping 3 (Mapped object 1 to si0)	1 to si0	UDINT	RW	Y	Y	Y	Y	Y
1604	Receive PDO mapping 5 (Number of objects)	0	USINT	RW	Y	Y	Y	Y	Y
	Receive PDO mapping 5 (Mapped object 1 to si0)	1 to si0	UDINT	RW	Y	Y	Y	Y	Y
1605	Receive PDO mapping 6 (Number of objects)	0	USINT	RW	Y	Y	Y	Y	Y
	Receive PDO mapping 6 (Mapped object 1 to si0)	1 to si0	UDINT	RW	Y	Y	Y	Y	Y
1607	Receive PDO mapping 8 (Number of objects)	0	USINT	RW	Y	Y	Y	Y	Y
	Receive PDO mapping 8 (Mapped object 1 to si0)	1 to si0	UDINT	RW	Y	Y	Y	Y	Y
1608	Receive PDO mapping 9 (Number of objects)	0	USINT	RW	Y	Y	Y	Y	Y
	Receive PDO mapping 9 (Mapped object 1 to si0)	1 to si0	UDINT	RW	Y	Y	Y	Y	Y

Object Ref. (0x)	Description	Data Type		Access	Profile				
		Sub-index	Type		VL Velocity	Homing	CST	CSP	CSV
1609	Receive PDO mapping 10 (Number of objects)	0	USINT	RW	Y	Y	Y	Y	Y
	Receive PDO mapping 10 (Mapped object 1 to si0)	1 to si0	UDINT	RW	Y	Y	Y	Y	Y
1A00	Transmit PDO mapping 1 (Number of objects)	0	USINT	RW	Y	Y	Y	Y	Y
	Transmit PDO mapping 1 (Mapped object 1 to si0)	1 to si0	UDINT	RW	Y	Y	Y	Y	Y
2smm	Drive parameter access (s = slot 0x0 to 0xF, mm=menu 0x00 to 0xFF)	pp (pp=par 0x00 to 0xFF)	[var]	RW	Y	Y	Y	Y	Y
3000	Position feedback encoder configuration	0	USINT	RW	Y	Y	Y	Y	Y
3003	Homing source (Number of last sub-index)	0	USINT	RO	N	Y	N	N	N
	Homing source (Homing switch source)	1	USINT	RW	N	Y	N	N	N
	Homing source (Freeze/marker source)	2	USINT	RW	N	Y	N	N	N
3004	Additional position loop scaling (Number of last sub-index)	0	USINT	RO	N	Y	N	Y	Y
	Additional position loop scaling (Numerator)	1	DINT	RW	N	Y	N	Y	Y
	Additional position loop scaling (Denominator)	2	DINT	RW	N	Y	N	Y	Y
3005	Error Reaction Configuration	0	USINT	RO	Y	Y	Y	Y	Y
	Error reaction mode	1	UINT	RW	Y	Y	Y	Y	Y
	Synchronization loss reaction mode	1	UINT	RW	Y	Y	Y	Y	Y
3008	Velocity mode redirection enable	0	USINT	RW	Y	N	Y	N	N
6007	Abort connection option code	3	INT	RW	Y	Y	Y	Y	Y
603F	Error code	0	UINT	RO	Y	Y	Y	Y	Y
6040	Control word	0	UINT	WO	Y	Y	Y	Y	Y
6041	Status word	0	UINT	RO	Y	Y	Y	Y	Y
6042	vl_target_velocity	0	INT	RW	Y	N	N	N	N
6043	vl_velocity_demand	0	INT	RO	Y	N	N	N	N
6044	vl_velocity_actual_value	0	INT	RO	Y	N	N	N	N

Safety Information	Introduction	Mechanical Installation	Electrical Installation	Getting started	Supported Objects	PDO, SDO & POWERLINK Modes	Object descriptions	Drive profile modes	Parameter descriptions	Diagnostics	Glossary of terms	Index
--------------------	--------------	-------------------------	-------------------------	-----------------	-------------------	---------------------------------------	---------------------	---------------------	------------------------	-------------	-------------------	-------

Object Ref. (0x)	Description	Data Type		Access	Profile				
		Sub-index	Type		VL Velocity	Homing	CST	CSP	CSV
6046	vl_velocity_min_max_amount (Number of last sub-index)	0	USINT	RO	Y	N	N	N	N
	vl_velocity_min_max_amount (Minimum velocity (rpm))	1	UDINT	RW	Y	N	N	N	N
	vl_velocity_min_max_amount (Maximum velocity (rpm))	2	UDINT	RW	Y	N	N	N	N
6048	vl_velocity_acceleration (Number of last sub-index)	0	USINT	RO	Y	N	N	N	N
	vl_velocity_acceleration (Delta speed value (rpm))	1	UDINT	RW	Y	N	N	N	N
	vl_velocity_acceleration (Delta time value (s))	2	UINT	RW	Y	N	N	N	N
6049	vl_velocity_deceleration (Number of last sub-index)	0	USINT	RO	Y	N	N	N	N
	vl_velocity_deceleration (Delta speed value (rpm))	1	UDINT	RW	Y	N	N	N	N
	vl_velocity_deceleration (Delta time value (s))	2	UINT	RW	Y	N	N	N	N
604A	vl_velocity_quick_stop (Number of last sub-index)	0	USINT	RO	Y	N	N	N	N
	vl_velocity_quick_stop (Delta speed value (rpm))	1	UDINT	RW	Y	N	N	N	N
	vl_velocity_quick_stop (Delta time value (s))	2	UINT	RW	Y	N	N	N	N
604B	vl_setpoint_factor (Number of last sub-index)	0	USINT	RO	Y	N	N	N	N
	vl_setpoint_factor (Numerator)	1	INT	RW	Y	N	N	N	N
	vl_setpoint_factor (Denominator)	2	INT	RW	Y	N	N	N	N
604C	vl_dimension_factor (Number of last sub-index)	0	USINT	RO	Y	N	N	N	N
	vl_dimension_factor (Numerator)	1	INT	RW	Y	N	N	N	N
	vl_dimension_factor (Denominator)	2	INT	RW	Y	N	N	N	N
605A	Quick stop option code	0	UINT	RW	Y	Y	Y	Y	Y
605B	Shutdown option code	0	UINT	RW	Y	Y	Y	Y	Y
605C	Disable operation option code	0	UINT	RW	Y	Y	Y	Y	Y
605D	Halt option code	0	INT	RW	Y	Y	Y	Y	Y
605E	Fault reaction option code	0	UINT	RW	Y	Y	Y	Y	Y
6060	Modes of operation	0	USINT	RW	Y	Y	Y	Y	Y
6061	Modes of operation display	0	USINT	RO	Y	Y	Y	Y	Y

Object Ref. (0x)	Description	Data Type		Access	Profile				
		Sub-index	Type		VL Velocity	Homing	CST	CSP	CSV
6062	Position demand value	0	DINT	RO	N	N	N	Y	N
6064	Position actual value	0	DINT	RO	Y	Y	Y	Y	Y
6065	Following error window	0	UDINT	RW	N	N	N	Y	N
6067	Position window	0	UDINT	RW	N	N	N	Y	N
606C	Velocity actual value	0	DINT	RO	Y	Y	Y	Y	Y
6073	Max current	0	UINT	RW	Y	Y	Y	Y	Y
6075	Motor rated current	0	UDINT	RO	Y	Y	Y	Y	Y
6077	Torque actual value	0	INT	RO	Y	Y	Y	Y	Y
6078	Current actual value	0	INT	RO	Y	Y	Y	Y	Y
607A	Target position	0	DINT	RW	N	N	N	Y	N
607C	Home offset	0	DINT	RW	N	Y	N	N	N
6080	Max motor speed	0	UDINT	RW	Y	Y	Y	Y	Y
6084	Profile deceleration	0	UDINT	RW	N	Y	Y	Y	Y
6085	Quick stop deceleration	0	UDINT	RW	N	Y	Y	Y	Y
608F	Position encoder resolution (Number of last sub-index)	0	USINT	RO	Y	Y	Y	Y	Y
	Position encoder resolution (Encoder increments)	1	UDINT	RO	Y	Y	Y	Y	Y
	Position encoder resolution (Motor revolutions)	2	UDINT	RO	Y	Y	Y	Y	Y
6091	Gear ratio (Number of last sub-index)	0	USINT	RO	Y	Y	Y	Y	Y
	Gear ratio (Motor revolutions)	1	UDINT	RW	Y	Y	Y	Y	Y
	Gear ratio (Shaft revolutions)	2	UDINT	RW	Y	Y	Y	Y	Y
6092	Feed constant (Number of last sub-index)	0	USINT	RO	Y	Y	Y	Y	Y
	Feed constant (Feed value)	1	UDINT	RW	Y	Y	Y	Y	Y
	Feed constant (Shaft revolutions)	2	UDINT	RW	Y	Y	Y	Y	Y
6098	Homing method	0	USINT	RW	N	Y	N	N	N
6099	Homing speeds (Number of last sub-index)	0	USINT	RO	N	Y	N	N	N
	Homing speeds (Speed during switch search)	1	UDINT	RW	N	Y	N	N	N
	Homing speeds (Speed during zero point search)	2	UDINT	RW	N	Y	N	N	N
609A	Homing acceleration	0	UDINT	RW	N	Y	N	N	N
60B1	Velocity offset	0	DINT	RW	N	N	Y	N	N
60B2	Torque offset	0	INT	RW	N	N	Y	Y	Y
60C0	Interpolation sub-mode select	0	INT	RW	N	N	Y	Y	Y

Safety Information
Introduction
Mechanical Installation
Electrical Installation
Getting started
Supported Objects
PDO, SPO & POWERLINK Modes
Object descriptions
Drive profile modes
Parameter descriptions
Diagnostics
Glossary of terms
Index

Object Ref. (0x)	Description	Data Type		Access	Profile				
		Sub-index	Type		VL Velocity	Homing	CST	CSP	CSV
60C1	Interpolation data record (Number of last sub-index)	0	USINT	RO	N	N	N	N	N
	Interpolation data record (Target position)	1	UDINT	RW	N	N	N	N	N
60C2	Interpolation time period (Number of last sub-index)	0	USINT	RO	N	N	Y	Y	Y
	Interpolation time period (Number of time periods)	1	USINT	RW	N	N	Y	Y	Y
	Interpolation time period (Time period exponent)	2	SINT	RW	N	N	Y	Y	Y
60F4	Following error actual value	0	DINT	RO	N	N	N	Y	N
60FB	Position control parameter set (Number of last sub-index)	0	USINT	RO	N	N	Y	Y	Y
	Position control parameter set (Proportional gain)	1	DINT	RO	N	N	Y	Y	Y
	Position control parameter set (Speed feed forward gain)	2	DINT	RO	N	N	Y	Y	Y
60FF	Target velocity	0	DINT	RW	N	N	Y	N	N
6502	Supported drive modes	0	UDINT	RO	Y	Y	Y	Y	Y

7.1 Process Data Objects (PDOs)

Cyclic data is implemented on POWERLINK networks by using "Process Data Objects" or PDOs. Separate data objects are used for transmitting (TxPDOs) and receiving (RxPDOs) data. PDO configuration objects are usually pre-configured in the POWERLINK Managing Node controller and downloaded to the SI-POWERLINK at network Initialization using SDOs (the user does not manually configure these SDOs, they are created and downloaded by the Managing Node).

The drive parameters are mapped into the object dictionary as 0x2XXX objects in the following way, (where Slot = 0 fro the drive's parameters).

Index: $0x2000 + (0x100 \times \text{Slot}) + \text{menu}$

Sub-index: $0x00 + \text{parameter number}$

For example Pr **20.021** would be index 0x2014 and the sub-index would be 0x15. The values are usually expressed in base 16 (hexadecimal), so care must be taken to enter the correct parameter number.

7.2 Service Data Object (SDO) parameter access

The service data object (SDO) provides access to all objects in the POWERLINK object dictionary and the drive's parameters are mapped in the same way as with PDOs (see above).

All other supported entries in the SI-POWERLINK object dictionary can also be accessed using SDOs. Refer to the Managing Node controller documentation for full details about implementing SDO transfers within the particular Managing Node controller.

NOTE Sub-index 0 for any menu will return the highest sub-index available for the object (i.e. the highest parameter number).

NOTE The following SDO services are supported:

- Initiate SDO Download (Write)
- Initiate SDO Upload (Read)
- Abort SDO Transfer (Error)

7.3 POWERLINK Modes (POWERLINK Mode and Basic Ethernet Mode)

7.3.1 POWERLINK Mode

In POWERLINK Mode network traffic follows the set of rules given by the POWERLINK standard for Real-time Ethernet communication. Network access is managed by a master, the POWERLINK Managing Node (MN). A node can only be granted the right to send data on the network via the MN. The central access rules preclude collisions, the network is therefore deterministic in POWERLINK Mode.

NOTE Any Ethernet infrastructure including managed switches, that are inserted within the POWERLINK network will cause delays that will impact determinism and synchronization.

7.3.2 Basic Ethernet Mode

SI-POWERLINK does not support Basic Ethernet mode.

7.3.3 Control Techniques PC tools

Control Techniques tools such as Connect are not currently supported over the POWERLINK network.

8 Object descriptions

8.1 Communication Object Descriptions

8.2 CANopen (CiA402) for POWERLINK

The CANopen protocol over POWERLINK uses a modified form of the CANopen object dictionary. This is specified in Table 8-1.

Table 8-1 CiA402 object dictionary

Index	Object dictionary area
0x0000 to 0x0FFF	Data type area
0x1000 to 0x1FFF	NMT (Network Management) area
0x2000 to 0x5FFF	Manufacturer specific area
0x6000 to 0x9FFF	Profile area
0xA000 to 0xFFFF	Reserved area

The object description format describes object related information such as size, range and descriptions and is detailed in Table 8-2.

Table 8-2 Object description format

<index>	<object name>		
Sub-index 0			
Access: <access>	Range: <range>	Size: <size>	Unit: <unit>
Default: <default>	Type: <type>		
Description: <description>			

For entries having sub-indices

Table 8-3 Object description format with sub-indices

<index>	<object name>		
Sub-index 0			
Access: <access>	Range: <range>	Size: <size>	Unit: <unit>
Default: <default>	Type: <type>		
Description: <description>			
Sub-index 1			
Access: <access>	Range: <range>	Size: <size>	Unit: <unit>
Default: <default>	Type: <type>		
Description: <description>			
Sub-index ...			

<index>	<object name>		
Sub-index 0			
Access: <access>	Range: <range>	Size: <size>	Unit: <unit>
Default: <default>	Type: <type>		
Description: <description>			
Sub-index n-1			
Access: <access>	Range: <range>	Size: <size>	Unit: <unit>
Default: <default>	Type: <type>		
Description: <description>			
Sub-index n			
Access: <access>	Range: <range>	Size: <size>	Unit: <unit>
Default: <default>	Type: <type>		
Description: <description>			

Definitions:

- <index>: A signed 16-bit number. This is the index of the object dictionary entry specified in four hexadecimal characters.
- <access>: A value describing how the object may be accessed (RW = read/write, RO = read-only and WO = write-only).
- <size>: The size of the object/sub-index in bytes.
- <unit>: The physical unit (e.g. ms, counts per second etc.).
- <type>: Data type:-

Data type	Size (bytes)	Range	Description
USINT	1	0 to 255	Unsigned short integer
SINT	1	-128 to 127	Signed short integer
UINT	2	0 to 65535	Unsigned integer
INT	2	-32768 to 32767	Signed integer
UDINT	4	0 to 2 ³²	Unsigned double integer
DINT	4	-2 ³¹ to 2 ³¹ -1	Signed double integer

8.2.1 NMT area

The first set of objects specify general communication settings.

Table 8-4 Device type object

0x1000	Device type		
Access: RO	Range: N/A	Size: 4 bytes	Unit: N/A
Default:	Dependent on drive type / mode (see description).	Type: UDINT	
Description:	<p>The primary profile is CiA402, so the value of this object is defined as follows:</p> <p>Bits 0 to 15 (Device Profile Number): 402 Bit 16 (Frequency Converter): x Bit 17 (Servo Drive): y Bit 18 (Stepper Motor): 0 Bit 24 (DC Drive - Control Techniques specific): 0 Bits 25-31 (Manufacturer specific): 0</p> <p>This value will be dependent on the drive operating mode and / or type. On Unidrive M600 and above in the open-loop, RFC-A or Regen modes or on Unidrive M400 and Commander C200/ C300, bit 16 will be set, while bit 17 will be clear. On Unidrive / Digitax HD M700 and above in RFC-S mode, bit 17 will be set, while bit 16 will be clear.</p>		

Table 8-5 Missing RX PDO

0x1C0B	DLL_CNLossSoC_REC		Object type: RECORD
Sub-index 0	Name: NumberOfEntries		
Access: Const	PDO Map: No	Range: N/A	Unit: N/A
		Data type: UNSIGNED8	Default: 3
Description:	Highest sub-index supported		
Sub-index 1	Name: CumulativeCnt_U32		
Access: RW	PDO Map: No	Range: 0 to 2 ³² -1	Unit: N/A
		Data type: UNSIGNED32	Default: 0
Description:	The cumulative counter is incremented by 1 every time a "Loss of SoC" error occurs.		
Sub-index 2	Name: ThresholdCnt_U32		
Access: RO	PDO Map: No	Range: 0 to 2 ³² -1	Unit: N/A
		Data type: UNSIGNED32	Default: 0
Description:	The threshold counter is incremented by 8 every time a "Loss of SoC" error symptom occurs and decremented by 1 at every cycle without reoccurrence of the error.		
Sub-index 3	Threshold_U32		
Access: RWS	PDO Map: No	Range: 0 to 2 ³² -1	Unit: N/A
		Data type: UNSIGNED32	Default: 15
Description:	<p>If ThresholdCnt_U32 (subindex 2) reaches the threshold, it is reset to 0 and the NMT state is switched to NMT_CS_PRE_OPERATIONAL_1.</p> <p>The threshold Counting may be deactivated by setting this value 0. If Threshold Counting is deactivated, no error reaction will occur</p>		

The default values for 0x1C0B are recommended for most applications.

Figure 8-1 Threshold error counter

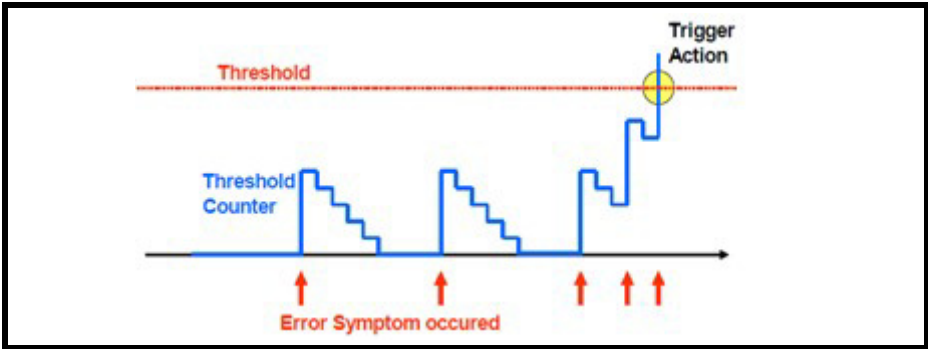

Figure 8-2 CRC errors

0x1C0D	DLL_CNLossPReq_REC			Object type: RECORD
Sub-index 0	Name: NumberOfEntries			
Access: Const	PDO Map: No	Range: 3	Unit: N/A	
		Data type: UNSIGNED8	Default: 3	
Description:	Highest sub-index supported			
Sub-index 1	Name: CumulativeCnt_U32			
Access: RW	PDO Map: No	Range: 0 to $2^{32} - 1$	Unit: N/A	
		Data type: UNSIGNED32	Default: 0	
Description:	The cumulative counter is incremented by 1 every time a "Loss of PReq" error occurs.			
Sub-index 2	Name: ThresholdCnt_U32			
Access: RO	PDO Map: No	Range: 0 to $2^{32} - 1$	Unit: N/A	
		Data type: UNSIGNED32	Default: 0	
Description:	The threshold counter is incremented by 8 every time a "Loss of PReq" error occurs and decremented by 1 at every cycle without reoccurrence of the error.			
Sub-index 3	Threshold_U32			
Access: RWS	PDO Map: No	Range: 0 to $2^{32} - 1$	Unit: N/A	
		Data type: UNSIGNED32	Default: 15	
Description:	If ThresholdCnt_U32 (subindex 2) reaches the threshold, it is reset to 0 and the NMT state is switched to NMT_CS_PRE_OPERATIONAL_1. The threshold Counting may be deactivated by setting this value 0. If Threshold Counting is deactivated, no error reaction will occur.			

The default values for 0x1C0D are recommended for most applications.

Table 8-6 Identity object

0x1018		Identity object	
Sub-index 0			
Access: RO	Range: N/A	Size: 1 byte	Unit: N/A
Default:	4	Type: USINT	
Description:	The number of the last sub-index in this object.		
Sub-index 1			
Access: RO	Range: N/A	Size: 4 bytes	Unit: N/A
Default:	0x000000F9 (249)	Type: UDINT	
Description:	This contains the POWERLINK vendor ID (0x000000F9).		
Sub-index 2			
Access: RO	Range: N/A	Size: 4 bytes	Unit: N/A
Default:	0x01mmvvt	Type: UDINT	
Description:	Product code. This contains the drive product code. Byte0 (tt): Drive type (0 = Leroy Somer; 1 = Mentor MP; 2 = M600/M700; 3 = M100 to M400; 4 = MEV; 5 = Elevator ES) Byte1 (vv): Drive variant/derivative (derived from Pr 11.028) Byte2 (mm): Drive mode (derived from Pr 11.084) Byte3 (gg): Drive generation (0 = Unidrive SP; 1 = Unidrive M)		
Sub-index 3			
Access: RO	Range: N/A	Size: 4 bytes	Unit: N/A
Default:	Derived from Pr S.00.002	Type: UDINT	
Description:	Module firmware version in the format <i>major.minor.version.build</i>		
Sub-index 4			
Access: RO	Range: N/A	Size: 4 bytes	Unit: N/A
Default:	0	Type: UDINT	
Description:	A value of zero will be returned rather than the module serial number		

8.2.2 RxPDO mappings

The objects in the 0x1600 to 0x1609 range are used to configure to mappings for the RPDO1 to RPDO10 respectively.

Table 8-7

0x1600	PDO_RxCommParam_00h_REC		Object type: ARRAY
...	...		Data type: UNSIGNED64
0x1609	PDO_RxCommParam_09h_REC		
Sub-index 0			
Name: NumberOfEntries			
Access: RWS	PDO Map: No	Range: 0...32	Unit: N/A
		Data type: UNSIGNED8	Default: 0
Sub-index 1...32			
Name: ObjectMapping			
Access: RWS	PDO Map: No	Range: 0 to 2 ⁶⁴ -1	Unit: N/A
		Data type: UNSIGNED64	Default: 0
Description:	Mapping configuration (see Table 8-8)		

The objects in the 0x1600 to 0x1609 range are used to configure to mappings for the RPDO1 to RPDO10 respectively.

Safety
Introduction
Mechanical installation
Electrical installation
Getting started
Supported Objects
PDO, SDO & POWERLINK Modes
Object descriptions
Drive profile modes
Parameter descriptions
Diagnostics
Glossary of terms
Index

To change the PDO mapping, the PDO shall be first deactivated by setting NumberOfEntries to 0. The new mapping may then be given by writing object mapping entries to sub-index 1 and higher using the data encoding described in Table 8-8

Table 8-8

Byte	Name	Description
0-1	Index	Index of the object to be mapped
2	Subindex	Sub-index of the object to be mapped
3	Reserved	For alignment purpose (unused)
4-5	Offset	Offset related to start of PDO payload (Bit count, it shall be a multiple of 8)
6-7	Length	Length of the mapped object (Bit count, it shall be multiple of 8 except if the data type is BOOLEAN, in this case the length shall be set to 1)

To enable the PDO mapping again, NumberOfEntries shall be set to the number of the highest sub-index containing the object mapping to be activated.

When a mapping is enabled, the cumulative length of all mapped objects does not violate the payload size limits specified by:

- NMT_CycleTiming_REC.IsochrRxMaxPayload_U16 (0x1F98:02)
- NMT_CycleTiming_REC.PReqActPayloadLimit_U16 (0x1F98:04), if the mapped node ID is the MN
- NMT_CycleTiming_REC.PResPayloadLimitList_AU16 (0x1F8D, sub index equal to the mapped node ID if it is a CN)

The mapping validity in a RPDO is also verified when the mapping is enabled.

In case of errors the update of subindex 0 is cancelled returning an appropriate SDO abort code; the possible errors and the relative codes are listed in Table 8-9.

Table 8-9

Error	Abort code	
The cumulative mapping size is too large to fit in the Powerlink frames	0x06040042	E_PDO_MAP_OVERRUN
The object doesn't exist	0x06020000	E_OBJECT_NOT_EXIST
The object cannot be mapped, or its access flags don't match the PDO direction	0x06040041	E_OBJECT_NOT_MAPPABLE
The bit offset is not a multiple of 8 (bit mappings is not supported)	0x08000000	E_GENERAL_ERROR
The mapped size is not a multiple of 8 and the data type is not BOOLEAN.		
The mapped size is not 1 and the data type is BOOLEAN.		
The mapped size is larger than the object size and the data type is numeric		
The mapped size is not equal to the object size and the data is not numeric.		

If the option module is fitted on a C200, C300 or M400 drive, the following restriction apply:

- The objects from 0x1602 to 0x1609 are not available (only 2 RPDO channels are provided)
- The valid data range of the sub index 1, and thus the maximum number of mappings per channel, is limited to 6.

8.2.3 TxPDO mappings

Table 8-10

0x1800	PDO_TxCommParam_00h_REC		Object type: RECORD
Sub-index 0	Name: NumberOfEntries		
Access: Const	PDO Map: No	Range: 2	Unit: N/A
		Data type: UNSIGNED8	Default: 2
Description:	Highest sub-index supported		
Sub-index 1	Name: NodeID_U8		
Access: RWS	PDO Map: No	Range: 0...254	Unit: N/A
		Data type: UNISGNED8	Default: 0
Description:	ID of the node that is transmitting the mapped data.		
Sub-index 2	Name: MappingVersion_U8		
Access: RWS	PDO Map: No	Range: 0...255	Unit: N/A
		Data Type: UNSIGNED8	Default: 0
Description:	Expected mapping version (see notes)		

The node ID field of this object (sub index 1) is provided for conformance and interoperability reasons, but according to the EPSG DS301 specifications it is not used as the option module implements a CN. The value shall be always set to 0 else the abort code E_GENERAL_ERROR (0x08000000) is returned and the mappings are not enabled.

The mapping version value (sub index 2) is copied in the PRes frames, to be transferred with the mapped data when the TPDO is enabled. See 4.3.1.11.1 for a description of the mapping version usage.

As for the RPDO communication parameters, the object 0x1800 cannot be written without the TPDO is disabled first, clearing the 0x1A00:00 object.

Table 8-11 0x1A00 PDO_TxMappParam_00h_AU64

0x1A00	PDO_TxMappParam_00h_AU64		Object type: ARRAY
			Data type: UNSIGNED64
Sub-index 0	Name: NumberOfEntries		
Access: RWS	PDO Map: No	Range: 0...32	Unit: N/A
		Data type: UNSIGNED8	Default: 0
Description:	Highest sub-index supported		
Sub-index 1...32	Name: ObjectMapping		
Access: RWS	PDO Map: No	Range: 0 to 2 ⁶⁴ -1	Unit: N/A
		Data type: UNSIGNED64	Default: 0
Description:	Mapping configuration (see Table 8-8)		

This object configures the TPDO mappings. Similar considerations apply as for the 0x1600-0x1609 objects, with the following differences:

- A single TPDO is available
- The overall size is validated against NMT_CycleTiming_REC.IsochrTxMaxPayload_U16 (0x1F98:01) and NMT_CycleTiming_REC.PResActPayloadLimit_U16 (0x1F98:05)

The same limitations about the maximum number mappings (sub index 0 valid range) apply as for the RPDO configuration.

For C200, C300 and M400 variants only sub-index 0x1A00:0 to 0x1A00:6 is supported.

Safety information
Introduction
Mechanical installation
Electrical installation
Getting started
Supported Objects
PDO, SDO & POWERLINK Modes
Object descriptions
Drive profile modes
Parameter descriptions
Diagnostics
Glossary of terms
Index

8.3 Communication Object Description

The CiA402 implementation interfaces with the drive primarily using drive parameters. To avoid malfunctions the parameters listed in Table 8-12 should not be adjusted by the user when the motion profiles are enabled.

Table 8-12 Parameters used by the CiA402 implementation

Parameter	Description	Parameter	Description
0.01.008	Negative Reference Clamp Enable	0.32.009	AMC Master User Position Reference
0.01.010	Bipolar Reference Enable	0.33.004	AMC Slave Reference
0.01.014	Reference Selector	0.34.001	AMC Stop Mode
0.01.015	Preset Selector	0.34.002	AMC Stop Reference
0.01.021	Preset Reference 1	0.34.006	AMC Speed Reference
0.02.001	Post Ramp Reference	0.34.007	AMC Reference Select
0.02.002	Ramp Enable	0.37.001	AMC EGB Enable Rigid Lock
0.02.005	Disable Ramp Output	0.37.004	AMC EGB Locking Speed Band
0.02.010	Acceleration Rate Selector	0.37.005	AMC EGB Locking Position Band
0.02.020	Deceleration Rate Selector	0.38.001	AMC Profile Acceleration
0.02.023	Deceleration Rate 3	0.38.002	AMC Profile Deceleration
0.02.050	Timing Options	0.38.003	AMC Profile Maximum Speed
0.04.008	Torque Reference	0.38.005	AMC Profile Disable
0.04.010	Torque Offset Select	0.38.009	AMC Main Profile Output Speed
0.04.011	Torque Mode Selector	0.39.001	AMC External Position Reference Select
0.06.001	Stop Mode	0.39.003	AMC External Speed Reference Select
0.06.042	Control Word	0.39.004	AMC External Speed Reference
0.08.072	Digital I/O Input Register 1	0.39.006	AMC Torque Feed-forward Enable
0.11.001	Option Synchronisation Select	0.39.008	AMC Position Error
0.31.001	AMC Select	0.41.001	AMC Enable
0.31.002	AMC Absolute Mode Enable	0.41.002	AMC Status
0.31.003	AMC Incremental Position Mode	0.41.007	AMC Following Error Window
0.31.012	AMC Rate Select	0.41.013	AMC Positive Hardware Limit Flag
0.31.014	AMC Speed Mode Enable	0.41.014	AMC Negative Hardware Limit Flag
0.32.001	AMC Master Source Select	0.41.023	AMC Hardware Limit Stop Mode
0.32.008	AMC Master User Speed Reference		

8.4 Additional position loop scaling

For the cases where different feedback devices with different resolutions are required for the drive velocity loop and the position loop, scaling of the position loop output will be provided.

When the value of these objects are configured to non-default values, they will be applied to the AMC scaling ratio. It will be simplified and multiplied to the AMC output user unit's ratio.

In order to prevent the overflow risk of AMC scaling parameters, before the new AMC output user unit's ratio taking action, it will be checked to make sure the numerator and the denominator of the multiplied result are within 1 to $2^{31}-1$ range. If outside the range, the AMC scaling ratios will stay at the previous values and the module will trip with 'APLS Failure'.

NOTE The values are evaluated, causing the AMC scaling parameters to be update only in the "Not ready to switch on" state and during the "Ready to switch on" to "Switched on" transition.

Table 8-13 Additional position loop scaling

0x3004	AdditionalPosLoopScaling_REC					Object type: RECORD		
Supported modes	pp	pv	vl	ip	hm	csp	csv	cst
Sub-index 0								
Access: RO	Range: N/A			Size: 1 byte		Unit: N/A		
Default:	2				Type: USINT			
Description:	The number of the last sub-index in this object.							
Sub-index 1								
Access: RW	Range: 1 to 0xFFFFFFFF			Size: 4 bytes		Unit: N/A		
Default:	1				Type: UDINT			
Description:	The additional position loop output scaling numerator							
Sub-index 2								
Access: RW	Range: 1 to 0xFFFFFFFF			Size: 4 bytes		Unit: N/A		
Default:	1				Type: UDINT			
Description:	The additional position loop output scaling denominator							

8.5 Error Reaction

Table 8-14 Error reaction

0x3005	Error Reaction							
Sub-index 0								
Name: Number Of Entries								
Access: Const	PDO Map: No			Range: N/A		Unit: N/A		
				Data type: UNSIGNED8		Default: 3		
Description:	Highest sub-index supported							
Sub-index 1								
Access: RWS	PDO Map: No			Range: 0 to 3		Unit: N/A		
				Data type: UNSIGNED8		Default: 0		
Description:	Network error reaction mode							
Sub-index 2								
Access: RWS				Range: 0 to 3		Unit: N/A		
				Data type: UNSIGNED8		Default: 0		
Description:	Synchronization loss reaction mode							

This object allows the independent configuration of the error reaction for network errors and synchronization loss. The possible reactions and their description are provided in Table 8-23. Please refer to table 11-25 for a list of the trips.

The network error reaction (sub-index 1) is activated if the counters associated with Missing RX PDO data object (0x1C0B) or CRC Errors object (0x1C0D) thresholds are reached, or if the managing node switches the NMT state out of the Operating state.

The Synchronization loss reaction (sub-index 2) is activated if the jitter on the synchronization message from the controller is too large.

NOTE The values are evaluated, causing the AMC scaling parameters to be update only in the “Not ready to switch on” state and during the “Ready to switch on” to “Switched on” transition.

The default values for 0x1C0B and 0x1C0D are recommended for most applications.

The default value for objects 0x3005:1 and 0x3005:2 of 0 will stop the motor according to object 0x605E:0, where the user can select disable, slow down ramp or quick stop ramp.

The synchronization loss error reaction is ignored if the drive is not able to synchronize (Commander C200, C300 and Unidrive M400) or if the synchronization is disabled because of the drive configuration.

All events capable of triggering the network error or sync loss reaction are always counted in parameters S.09.001 – S.09.008

Table 8-15

Mode	Description
0	Signal a drive alarm and gracefully stop the motor if a motion profile is running
1	Signal a drive alarm but doesn't stop the motor
2	Trip the drive: if a motion profile is running, the motor is gracefully stopped before
3	Trip the drive immediately: if the motor was running, it will coast

8.6 Feedback encoder source

Table 8-16 Feedback encoder source

0x3000	Position Feedback Encoder Configuration					Object type: VAR		
Supported Modes	pp	pv	vl	ip	hm	csp	csv	cst
Sub-index 0								
Access: RW		Range: 0 to 11		Size: 1 byte		Unit: N/A		
Default:		0		Type: USINT8				
Description:		<p>This specifies the source for position controller feedback, and the source for CiA402 position feedback objects, even when position control is not being performed. This will have a value as follows:</p> <ul style="list-style-type: none"> 0 - The feedback source for the position controller will match the drive motor control feedback source (as specified in menu 3). 1 - Drive feedback source, P1 interface. 2 - Drive feedback source, P2 interface. 3 - Slot 1 position feedback module, P1 interface. 4 - Slot 1 position feedback module, P2 interface. 5 - Slot 2 position feedback module, P1 interface. 6 - Slot 2 position feedback module, P2 interface. 7 - Slot 3 position feedback module, P1 interface. 8 - Slot 3 position feedback module, P2 interface. 11 - Sensorless (the sensorless algorithm estimates position feedback). <p>This value will be ignored on drives where no encoder input is present. This object is read upon an NMT state transition from NMT_CS_PRE_OPERATIONAL_2 to NMT_CS_READY_TO_OPERATE.</p>						

NOTE The value of objects 0x3000 will be ignored on drives which do not support position feedback.

8.7 Enhanced Loop Control

Enhanced loop Scaling is enabled by setting this object to TRUE. It increases the velocity loop resolution within the AMC, to match as close as possible the resolution of the Encoder as defined via 0x608F, using both the AMC Master input and AMC Slave user unit's ratios

Table 8-17 Enhanced Loop Control

0x3009		Enhanced Loop Control							
Supported modes	pp	pv	vl	ip	hm	csp	csv	cst	
Sub-index 0			Range: 0 to 1						
Access: RWO			Data type: BOOLEAN			Unit: N/A			
			Handling rate: 40 ms			Default: FALSE			
Description:	Enable the Enhanced Loop Control Functionality								

Safety Information
Introduction
Mechanical Installation
Electrical Installation
Getting started
Supported Objects
PDO, SDO & POWERLINK Modes
Object descriptions
Drive profile modes
Parameter descriptions
Diagnostics
Glossary of terms
Index

8.8 Moving Average Filter

Table 8-18 Moving Average Filter

0x300A		Moving Average Filter						
Supported modes	pp	pv	vl	ip	hm	csp	csv	cst
Sub-index 0			Range: 0 to 31					
Access: RW			Data type: UNSIGNED8			Unit: N/A		
			Handling rate: On operating mode change On enter or return to "Operation enabled" state			Default: FALSE		
Description:	Interpolation filter configuration							

$$Y(n) = Y(n-1) + \frac{X(n) - X(n-s)}{s} \text{ when } n > s$$

$$Y(n) = Y(n-1) + \frac{X(n) - X(0)}{s} \text{ when } n \leq s$$

$$Y(0) = X(0) \text{ when } n = 0$$

Where:

- n is the iteration i.e. increments after each new target position arrives. n = 0 when entering CiA402 operational state.
- Y(n) is the interpolator input at the nth iteration of the filter
- Y(n-1) is the interpolator input at the (n-1)th iteration (i.e. the previous iteration)
- X(n) is the target value filter input at the nth iteration of the filter
- X(n-s) is the target input value at the (n-s) iteration
- S is the size of the filter specified by the object value

The window filter is executed at the rate of the network cycle time; hence it operates before the interpolator.

One of the side effects of the window filter is to add a delay in the feedback loop. Therefore, the following error, as seen by the PLC, will be increased by the length of the filter. The option module does not hide this fact, so it will impact on status word target reached.

9 Drive profile modes

9.1 Common profile features

9.1.1 Sequencing control

The behaviour of the sequencing control is shown in Figure 9-1 on page 48. This state machine indicates how the drive will be controlled. Status word is abbreviated to “SW” in the diagram.

The initial state of the CiA402 state machine is “NOT READY TO SWITCH ON”. The module must be in the POWERLINK operational state before any further state transitions can happen. If the module goes back to pre-operational state when the CiA402 state machine is in the “SWITCH ON DISABLED”, “READY TO SWITCH ON”, “SWITCHED ON”, “OPERATION ENABLE” or “QUICK STOP ACTIVE” states, the option will transition to the “NOT READY TO SWITCH ON” state.

This implies that the drive will stop according to the configured stopping method and the drive will be inhibited after the motor has stopped.

In the state “QUICK STOP ACTIVE”, the currently selected mode of operation indicates how a quick stop should be handled. When the drive is stopped (using the ramp defined in 0x605A Quick_Stop_Option_Code object), and the Quick stop option code doesn't indicate that the state should remain at “QUICK STOP ACTIVE”, the state will move to “SWITCH ON DISABLED”.

If one of the drive limit switches becomes active, the drive will be slowed down with the ramp specified by the quick stop option code.

The “internal limit active” bit (11) of the status word will be updated in states “OPERATION ENABLED” and “QUICK STOP ACTIVE”. It will be set as soon as the hardware/software limit becomes active, and it will be cleared as soon as the limit becomes inactive. This bit is supported in cyclic sync position mode, cyclic sync velocity mode, interpolation position mode and homing mode.

The default value in mode_of_operation will be 2 (i.e. velocity mode) on an Open loop drive or mode, and it will be 8 (Cyclic Sync Position mode) with RFC-A or RFC-S (and on any drive and mode combination that can support position control). It can be changed at any time as long as the motor is at zero speed. If the mode of operation is correct and any associated data is correct, the change will occur and the new operation mode will be reflected in the mode_of_operation_display object. If the mode is invalid, or data is incorrect, the mode of operation will not be changed.

The mode_of_operation object is read in all CiA402 states so that the operating mode can be changed at any time, which is necessary for homing: some axes (e.g. vertical axes) have to be homed and start ordinary positioning operation without the need to remove power from the motor, which, on a vertical axis, might allow a tool, to fall and be damaged or cause damage. However, the state machine will not perform a mode change until the motor is at zero speed, as far as can be determined.

The max_motor_speed object specifies a maximum speed in RPM; it will have a default value matching the drive parameter Pr **01.006** (“Maximum reference clamp”, the object value will be set to the value of Pr **01.006** at power up, or if Pr **01.006** is explicitly changed), and it will be used to set this parameter. It will also be scaled and used to set the position controller output speed clamp (Pr **39.011**). It will be applied in all of the CiA402 operating modes. For example, if the max_motor_speed object is set to 6000, the position controller output speed clamp will be set to a value to give a limit of 6000rpm.

The initial value of gear_ratio, feed_constant and additional_position_loop_scaling objects (e.g. user configuration in start-up list) will be checked during the POWERLINK operational state transition ‘READY TO SWITCH ON’ to ‘SWITCHED ON’. During earlier CiA402 state machine transitions, the value of these objects can be changed at any time. However the change won't take effect until a CiA402 state transition from ‘READY TO SWITCH ON’ to ‘SWITCHED ON’ happens. If any ratio fails to be applied, the POWERLINK module will not apply new values to the AMC.

Safety Information
Introduction
Mechanical Installation
Electrical Installation
Getting started
Supported Objects
PDO, SDO & POWERLINK Modes
Object descriptions
Drive profile modes
Parameter descriptions
Diagnostics
Glossary of terms
Index

Figure 9-1 CoE state machine diagram

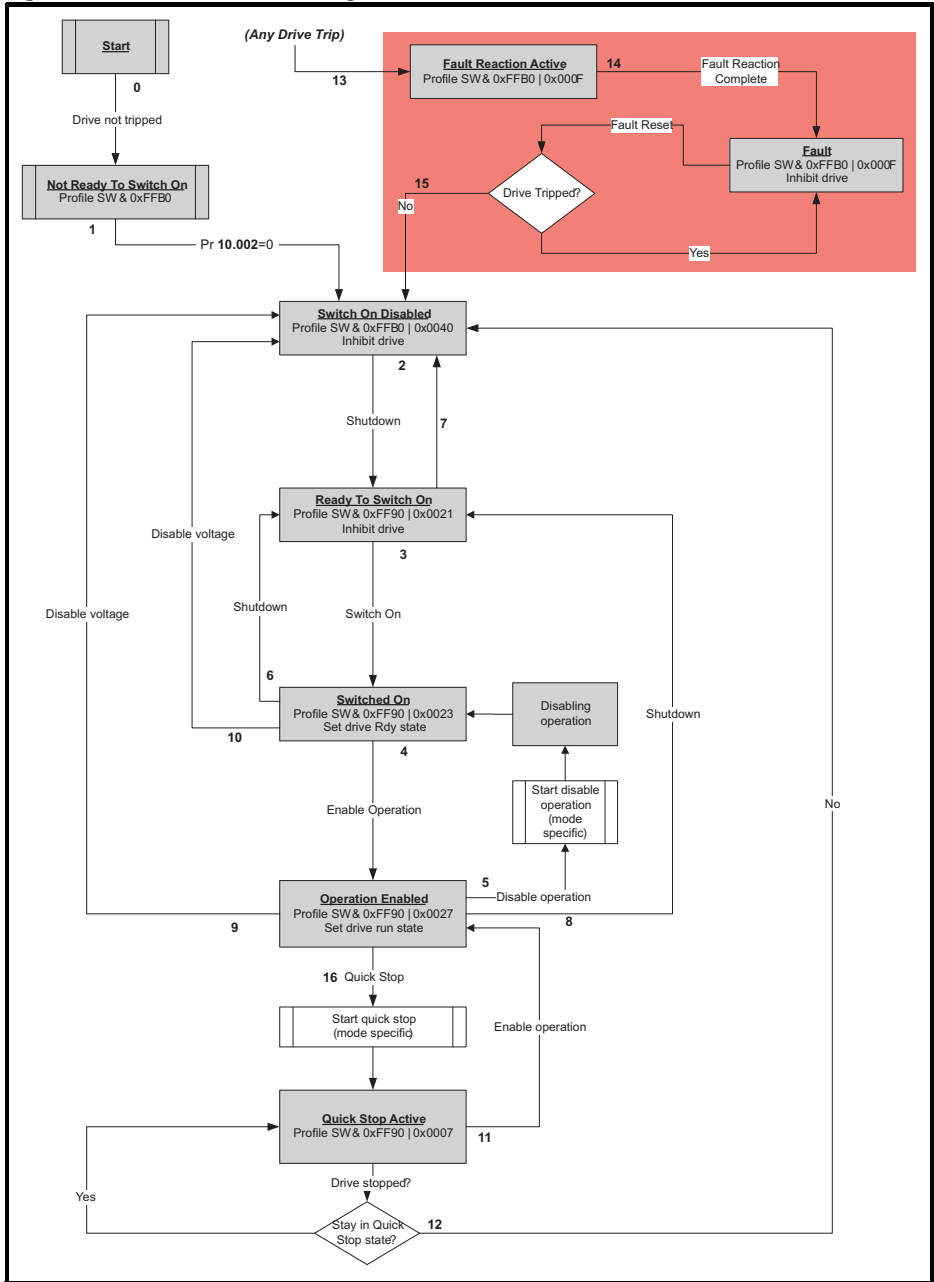

Table 9-1 CoE state machine transition and events

Transition	Event(s)	Action(s)
0	Automatic transition after power-on or reset application	Drive device self-test and/or self Initialization shall be performed
1	Automatic transition	Communication shall be activated
2	Shutdown command from control device or local signal	None
3	Switch on command received from control device or local signal	Power section shall be switched on if not already switched on
4	Enable operation command received from control device or local signal	Drive function shall be enabled and clear all internal set-points
5	Disable operation command received from control device or local signal	Drive function shall be disabled
6	Shutdown command received from control device or local signal	The high-power shall be switched off immediately, and the motor shall be free to rotate if not braked; additional action depends on the shutdown option code
7	Quick stop or disable voltage command from control device or local signal	None
8	Shutdown command from control device or local signal	The high-power shall be switched off immediately if possible, and the motor shall be free to rotate if not braked
9	Disable voltage command from control device or local signal	The high-power shall be switched off immediately if possible, and the motor shall be free to rotate if not braked
10	Disable voltage or quick stop command from control device or local signal	The high-power shall be switched off immediately if possible, and the motor shall be free to rotate if not braked
11	Quick stop command from control device or local signal	The quick stop function shall be started
12	Automatic transition when the quick stop function is completed and quick stop option code 1, 2, 3 or 4 disable voltage command received from control device (dependant on the quick stop option code)	The power section shall be switched off
13	Fault signal	The configure fault reaction function shall be executed
14	Automatic transition	The drive function shall be disabled; the high-power may be switched off
15	Fault reset command from control device or local signal	A reset of the fault condition is carried out, if no fault exists currently on the drive device; after leaving the Fault state, the Fault reset bit in the controlword shall be cleared by the control device
16	Enable operation command from control device, if the quick stop option code is 5, 6, 7 or 8	The drive function shall be enabled

Safety information
Introduction
Mechanical installation
Electrical installation
Getting started
Supported Objects
PDO, SDO & POWERLINK Modes
Object descriptions
Drive profile modes
Parameter descriptions
Diagnostics
Glossary of terms
Index

9.1.2 0x6040 Controlword

This provides the primary method of controlling the behavior of the drive e.g. enabling, disabling, resetting, etc. Table 9-2 describes the format of the control word. The individual bits are used in combinations (see Table 9-4) to sequence the drive through the state machine described in Figure 9-1.

Table 9-2 Controlword structure

0x6040		Controlword													
Access: RW				Range: 0 to 65535				Size: 2 bytes				Unit: N/A			
Default: N/A								Type: UINT							
Description: Provides the primary method of controlling the behavior of the drive.															
15	14	13	12	11	10	9	8	7	6	5	4	3	2	1	0
ms				r	oms	h	fr	oms				eo	qs	ev	so

LEGEND: ms = manufacturer-specific; r = reserved; oms = operation mode specific; h = halt; fr = fault reset; eo = enable operation; qs = quick stop; ev = enable voltage; so = switch on

Table 9-3 Controlword bits description

Bit	Name	Description
7, 3, 2, 1, 0	Command	These bits encode the commands used to sequence the drive through the CiA402 state machine.
4, 5, 6, 9	Operatin mode specific	Please refer to the operating modes description.
8	Halt	If this bit is set, the motion in progress is interrupted according to the behaviour specified by the halt option code (object 0x605D). If the pp or pv profiles are active, the interrupted movement is resumed after the releasing the halt function.
10	Reserved	These bits are ignored: they may be used for future development and they should be always set to zero.
10 to 15	Manufacturer specific	

Table 9-4 Command coding

Command	Bits of the controlword				
	Bit 7	Bit 3	Bit 2	Bit 1	Bit 0
Shutdown	0	X	1	1	0
Switch on	0	0	1	1	1
Switch on + enable operation	0	1	1	1	1
Disable voltage	0	X	X	0	X
Quick stop	0	X	0	1	X
Disable operation	0	0	1	1	1
Enable operation	0	1	1	1	1
Fault reset		X	X	X	X

9.1.3 0x6041 Statusword

This provides feedback about the current operating state of the drive. Table 9-6 describes the format of the status word and illustrates how the individual statusword bits are combined to represent the current state of the drive.

Table 9-5 Statusword description

0x6041		Statusword	
Access: RW		Range: 0 to 65535	Size: 2 bytes
Unit: N/A			
Default:	N/A	Type:	UINT
Description:	This provides feedback about the current operating state of the drive.		

Table 9-6 Statusword structure

15	14	13	12	11	10	9	8	7	6	5	4	3	2	1	0
ms		oms		ila	tr	rm	ms	w	sod	qs	ve	f	oe	so	rtso

LEGEND: ms = manufacturer-specific; oms = operation mode specific; ila = internal limit active; tr = target reached; rm = remote; w = warning; sod = switch on disabled; qs = quick stop; ve = voltage enabled; f = fault; oe = operation enabled; so = switched on; rtso = ready to switch on

Table 9-7 Status word bits description

Statusword	State
xxxx xxxx x0xx 0000b	Not ready to switch on
xxxx xxxx x1xx 0000b	Switch on disabled
xxxx xxxx x01x 0001b	Ready to switch on
xxxx xxxx x01x 0011b	Switched on
xxxx xxxx x01x 0111b	Operation enabled
xxxx xxxx x00x 0111b	Quick stop active
xxxx xxxx x0xx 1111b	Fault reaction active
xxxx xxxx x0xx 1000b	Fault

Safety information
Introduction
Mechanical installation
Electrical installation
Getting started
Supported Objects
PDO, SDO & POWERLINK Modes
Object descriptions
Drive profile modes
Parameter descriptions
Diagnostics
Glossary of terms
Index

Table 9-8 State coding

Bit	Name	Description
0, 1, 2, 3, 5, 6	State	The current CiA402 state is encoded in these bits
4	Voltage enabled	The main voltage is present
7	Warning	A drive warning is active; the error cause can be obtained reading the object 0x603F
9	Remote	This bit is cleared when the control word is not processed: <ul style="list-style-type: none"> The network state is not NMT_CS_READY_TO_OPERATE or NMT_CS_OPERATIONAL The CiA402 profiles are disabled by Pr.S.00.034.
10	Target reached	Set-point reached: the set-point is operation mode specific, see the modes description for more information. This bit is also set to 1, independently to the operating mode in the following cases: <ul style="list-style-type: none"> The operating mode is change The motor stopped after a halt or quick stop operation
11	Internal limit reached	One hardware limit switch is active, or the target position is limited by the 0x607D object. This bit is valid only if the pp, ip, csp and csv modes are selected.
12, 13	Operation mode specific	Please refer to the operating modes description.
8, 15, 14	Manufacturer specific	All manufacturer specific bits are always set to zero.

9.1.4 0x6044 VI Velocity Actual Value

0x6044		VI Velocity Actual Value								
Supported modes		pp	pv	vl	lp	hm	csp	csv	cst	
Sub-index		Range: -2 ¹⁵ to 2 ¹⁵ -1								
Access: RO		Data type: INTERGER16					Unit: UU			
		Update rate: 250 µs					Default: 0			
Description:		Actual velocity feedback								

The object 0x6044 is defined by the EN61800 specifications only in the velocity mode; the option module however updates it independently to the active operating mode. The object value is calculated from a parameter dependent on the drive type and mode.

9.1.5 Quick stop option code

This object indicates what action is performed when the quick stop function is executed. The slow down ramp is the deceleration value of the used mode of operations.

Table 9-9 Quick stop option code

0x605A		Quick stop option code				
Sub-index 0						
Access: RW		Range: 0 to 6		Size: 2 bytes		Unit: N/A
Default: 2		Type: INT				
Description:		Specifies what action is performed in the event of a quick stop function.				

Table 9-10 Quick stop value definitions

Value	Definition
0	Disable drive function
1	Slow down on slow down ramp and transit into Switch on disabled
2	Slow down on quick stop ramp and transit into Switch on disabled
5	Slow down on slow down ramp and stay in Quick stop active
6	Slow down on quick stop ramp and stay in Quick stop active

9.1.6 0x605B Shutdown option code

This object is used to control what action is performed if there is a transition from the Operation Enabled state to the Ready To Switch On state.

Table 9-11 Shutdown option code

0x605B		Shutdown option code	
Sub-index 0			
Access: RW	Range: -1 to 1	Size: 2 bytes	Unit: N/A
Default: N/A	Type: INT		
Description:	Used to control what action is performed if there is a transition from the Operation Enabled state to the Ready To Switch On state.		

Table 9-12 Shutdown option code values

Value	Definition
0	Disable drive function (switch off the drive power stage)
1	Slow down with slow down ramp; disable the drive function
-1	Slow down with slow down ramp, wait for brake to be fully applied (by waiting for Zero Hold (Pr 6.008) to clear); then disable the drive

9.1.7 0x605C Disable operation option code

Disable drive function (switch off the drive power stage).

This object is used to control what action is performed if there is a transition from the 'Operation Enabled' state to the 'Switched On' state.

Table 9-13 Disabled operation option code

0x605C		Disable operation option code	
Sub-index 0			
Access: RW	Range: 0 to 1	Size: 2 bytes	Unit: N/A
Default: N/A	Type: INT		
Description:	This object is used to control what action is performed if there is a transition from the Operation Enabled state to the Switched On state.		

Table 9-14 Disable operation option code values

Value	Definition
0	Disable drive function (switch off the drive power stage)
1	Slow down with slow down ramp; disable the drive function

9.1.8 0x605D Halt option code

This object shall indicate what action is performed when the halt function is executed.

Fault reaction option code

0x605D	Halt option code		
Sub-index 0			
Access: RW	Range: 0 to 2	Size: Signed 16	Unit: N/A
Default: 0	Type: INT		
Description: This object is used to control what action is performed if a Halt is called.			

Fault reaction option code values

Value	Definition
0	Reserved (no action)
1	Slow down with slow down ramp; stay in Operation enabled
2	Slow down with quick stop ramp; stay in Operation enabled

9.1.9 0x605E Fault reaction option code

This object is used to control what action is performed when a fault is detected (PDO loss).

This object is ignored if the drive is tripped.

Table 9-15 Fault reaction option code

0x605E	Fault reaction option code		
Sub-index 0			
Access: RW	Range: 0 to 2	Size: 2 bytes	Unit: N/A
Default: N/A	Type: INT		
Description: This object is used to control what action is performed when a fault is detected.			

Table 9-16 Fault_reaction_option_code values

Value	Definition
0	Disable drive function, motor is free to rotate
1	Slow down on slow down ramp
2	Slow down on quick stop ramp

9.1.10 0x6060 Modes of operation

This object is used to request a change in the mode of operation.

Table 9-17 Modes of operation

0x6060	Modes of operation		
Sub-index 0			
Access: RW	Range: 0 to 10	Size: 1 byte	Unit: N/A
Default: 2	Type: SINT		
Description: This object is used to request a change in the mode of operation.			

NOTE The default for this object is dependent on the drive operating mode. In Open-loop the default is 2. In RFC-S the default is 8.

Table 9-18 Modes of operation values

Value	Definition	Supported drives	Supported modes
0	No mode change		
1	Profile position mode	M70x, M75x	RFC-A, RFC-S
2	vl velocity mode	C200/C300, M400, M600/M70x, M75x	OL, RFC-A, RFC-S
6	Homing mode	M70x, M75x	RFC-A, RFC-S
8	Cyclic sync position mode	M70x, M75x	RFC-A, RFC-S
9	Cyclic sync velocity mode	M70x, M75x	RFC-A, RFC-S
10	Cyclic sync torque mode	M600/M70x, M75x	RFC-A, RFC-S

The change of the active operating mode can be requested by writing the value corresponding to the new mode in the 0x6060 object. If the motor is moving, this object is not evaluated until the speed is below the Zero Speed Threshold (Pr.03.005). The supported modes depend on the drive type and mode.

9.1.11 0x6061 Modes of operation display

This read only object indicates the active mode of operation.

Table 9-19 Modes of operation display

0x6061		Modes of operation display			
Sub-index 0					
Access: RO	Range: 0 to 10	Size: 1 byte	Unit: N/A		
Default: N/A	Type: SINT				
Description: Used to provide the active mode of operation.					

Table 9-20 Modes of operation display values

Value	Definition	Supported drives	Supported modes
0	No mode change		
1	Profile position mode	M70x, M75x	RFC-A, RFC-S
2	vl velocity mode	C200/C300, M400, M600/M70x, M75x	OL, RFC-A, RFC-S
6	Homing mode	M70x, M75x	RFC-A, RFC-S
8	Cyclic sync position mode	M70x, M75x	RFC-A, RFC-S
9	Cyclic sync velocity mode	M70x, M75x	RFC-A, RFC-S
10	Cyclic sync torque mode	M600/M70x, M75x	RFC-A, RFC-S

9.1.12 0x6064 Position Actual Value

0x6064		PositionActualValue I32							
Supported modes	pp	pv	vl	lp	hm	csp	csv	cst	
Sub-index0		Range: -2 ³¹ to 2 ³¹ -1							
Access: RO	PDO Map:TPDO	Data type: INTERGER32				Unit: UU			
		Update rate: 250 μs				Default: N/A			
Description:		Actual position feedback							

The 0x6064 object is updated in all operating modes, provided that the feedback source is configured via the object 0x3000 and that it is supported by the drive

9.1.13 0x6080 Maximum Motor Speed

0x6080		Maximum Motor Speed							
Supported modes		pp	pv	vl	lp	hm	csp	csv	cst
Sub-index0		Range: 0 to 0xFFFFFFFF							
Access: RW		Data type: UDINT					Unit: UU/s		
		Handling rate: 40 ms					Default: N/A		
Description:	Maximum velocity for profiled motion								

This object indicates the configured maximum allowed speed for the motor in either direction, to protect the motor from damages. It is automatically initialized with the value from Pr.01.006 after the proper conversion is applied in the following cases:

- Startup
- The CiA402 profiles are reenabled
- The operating mode is changed

When the object is written, a copy of the value is converted applying the appropriate scaling, then it is copied to Pr.01.006 (Maximum Reference Clamp) and Pr.39.011 (AMC Output Speed Clamp), within 40 ms. Please note that except when the object is initialized, any user change to the parameters have no effect on it: the user should not change the parameters when the CiA402 profiles are enabled.

9.1.14 0x606C Velocity Actual Value

0x606C		Velocity Actual Value							
Supported modes		pp	pv	vl	lp	hm	csp	csv	cst
Sub-index0		Range: -2^{31} to $2^{31}-1$							
Access: RO		Data type: INTEGER32					Unit: UU/s		
		Handling rate: 250 μ s					Default: N/A		
Description:	Actual velocity feedback								

The velocity actual value is not available on drives without position feedback inputs or if the drive is configured in the Open Loop mode.

9.1.15 0x6073 Maximum Current

0x6073		Max Current							
Supported modes		pp	pv	vl	lp	hm	csp	csv	cst
Sub-index0		Range: 0 to $2^{16}-1$							
Access: RW		Data type: UNSIGNED16					Unit: 0.1 % rated motor current		
		Handling rate: 40 ms					Default: N/A		
Description:	Maximum current value								

The maximum output current is limited by the value specified by the 0x6073 object via Pr.04.007 parameter (Symmetrical Current Limit). The object is automatically initialized with the parameter value in the following cases:

- Startup
- The CiA402 profiles are re-enabled
- The operating mode is changed

When the object is written, the new value is copied to Pr.04.007 within 40 ms. The user should not change the parameter when the CiA402 profiles are enabled.

9.1.16 0x6075 Motor Rated Current

0x6075		Motor Rated Current							
Supported modes	pp	pv	vl	lp	hm	csp	csv	cst	
Sub-index0		Range: 0 to 999999							
Access: RO		Data type: UNSIGNED32					Unit: mA		
		Update rate: 40 ms					Default: Pr.11.060		
Description:		Motor rated current							

This object indicates the configured motor rated current; all relative current data refers to this value, expressed in mA. The object value is updated with the Pr.05.007 value in background.

9.1.17 0x6077 Torque Actual Value

0x6077		Torque Actual Value							
Supported modes	pp	pv	vl	lp	hm	csp	csv	cst	
Sub-index0		Range: 0 to 999999							
Access: RO		Data type: UNSIGNED16					Unit: 0.1 % rated motor torque		
		Update rate: 250 µs					Default: N/A		
Description:		Torque actual value feedback							

This object reports the estimated torque at the shaft, it is obtained from the torque producing current represented as a percentage of the rated value for the motor. If the option module is fitted on a Unidrive M600/M70x or Digitax HD drive, the value is directly copied from Pr.04.026 (Percentage torque). If the module is fitted on Unidrive M400 or a Commander drive, the value is instead copied from Pr.04.020 (Percentage load), provided that the output frequency (Pr.05.001) is below the motor rated frequency (Pr.05.006), else the value is adjusted as follows:

$$Obj_{6077} = Pr.04.020x \frac{Pr.05.006 (Motor\ rated\ frequency)}{Pr.05.001 (Output\ frequency)}$$

9.1.18 0x6078 Current Actual Value

0x6078		Current Actual Value								
Supported modes	pp	pv	vl	lp	hm	csp	csv	cst		
Sub-index0		Range: 0 to 999999								
Access: RO		PDO Map: TPDO		Data type: INTEGER16					Unit: 0.1 % rated motor current	
		Update rate: 250 µs					Default: N/A			
Description:		Current actual value feedback								

The current actual value is directly copied from Pr.04.020 (Percentage Load): it represents the percentage ratio between the actual torque producing current (Pr.04.002) and the rated value for the motor

9.1.19 0x6084 Profile deceleration

This object is used to configure the deceleration rate used to stop the motor when the quick stop function is activated and the quick stop code object (0x605A) is set to 1 or 5. This object is also used for shutdown when shutdown option code (0x605B) is set to 1, and for disable operation when disable operation option code (0x605C) is set to 1. It is also used if the fault reaction code object (0x605E) is 1. The value is given in user defined acceleration units. This object will not be used for vl velocity mode.

Table 9-21 Profile deceleration

0x6084		Profile Deceleration							
Supported modes	pp	pv	vl	lp	hm	csp	csv	cst	
Sub-index0		Range: 0 to $2^{32}-1$							
Access: RW			Data type: UNSIGNED32				Unit: UU/s ²		
		Handling rate: 250 µs				Default: 65535			
Description:	Normal deceleration ramp								

9.1.20 0x6085 Quick stop deceleration

This object is used to configure the deceleration rate used to stop the motor when the quick stop function is activated and the quick stop code object (0x605A) is set to 2 or 6. The quick stop deceleration is also used if the fault reaction code object (0x605E) is 2. The value is given in user-defined acceleration units. This object will not be used for vl velocity mode.

Table 9-22 Quick stop deceleration

0x6085		Quick Stop Deceleration							
Supported modes	pp	pv	vl	lp	hm	csp	csv	cst	
Sub-index0		Range: 0 to $2^{32}-1$							
Access: RW			Data type: UNSIGNED32				Unit: UU/s ²		
		Handling rate: 40 ms				Default: 65535			
Description:	Quick stop deceleration ramp								

9.1.21 0x60B2 Torque Offset

The torque offset is applied setting Pr.0.04.008 (Torque Reference), provided that a supported operating mode is selected.

0x60B2		TorqueOffset I32							
Supported modes	pp	pv	vl	lp	hm	csp	csv	cst	
Sub-index0		Range: -2^{15} to $2^{15}-1$							
Access: RW			Data type: INTEGER16				Unit: N/A		
		Read rate: 250 µs				Default: 0			
Description:	Offset added to the target torque or to the torque setpoint.								

9.1.22 Profile units

The SI-POWERLINK implementation provides a means to convert profile units into position controller and drive units. All scaling values are standard profile objects. The following objects are supported:

Table 9-23 Supported profile units

Index	Name
0x608F	<i>position_encoder_resolution</i>
0x6091	<i>gear_ratio</i>
0x6092	<i>feed_constant</i>

The initial value of the feed constant object (0x6092) shall be calculated from the normalization turns parameter of the associated encoder channel if the default values have not been modified. If either value is non default the values will be taken as is.

For positions, the scaling control will include a feed constant, a gear ratio and an encoder resolution. These values will be combined together to scale the drive position (i.e. encoder increments) to position in user-defined unit by the following formula.

$$\text{user defined unit position} = \frac{\text{drive position} \cdot \text{feed constant}}{\text{position encoder resolution} \cdot \text{gear ratio}}$$

It will be possible to change these values non-cyclically (i.e. using SDOs), It will not, however, be possible to change these values cyclically (i.e. by mapping PDOs to them).

These scaling objects will be combined together to scale drive velocities (i.e. encoder increments per second) to velocity in user-defined unit by the following formula.

$$\text{user defined unit velocity} = \frac{\text{drive velocity} \cdot \text{feed constant}}{\text{position encoder resolution} \cdot \text{gear ratio}}$$

It will be possible to change these values non-cyclically (i.e. using SDOs). It will also be necessary to re-scale velocity limit values with the new factor. It will not be possible to change these values cyclically (i.e. by mapping PDOs to them)

The position encoder resolution object 0x608F will be read-only and its value will be derived from drive parameter values. The numerator of 0x608F will be derived from the normalization turns parameter of the associated encoder channel. The denominator of 608F will be always 1.

The user-defined position and velocity values will be handled in signed 32-bit values. The scaled position will rollover the boundary if it is too large.

When the gear ratio or the feed constant is applied, the combination of

$\frac{\text{feed constant}}{\text{position encoder resolution} \cdot \text{gear ratio}}$ will be calculated and simplified. The result will be applied

to the AMC slave user unit's ratio and its inverse value will be put in the AMC output user unit's ratio. To prevent the overflow risk of AMC ratio parameters, before being applied, the size will be checked to make sure the numerator and the denominator of the combined results are within 1 to $2^{31}-1$ range. If not, the module will trip with 'Scaling failure' and the AMC scaling ratios will stay previous value.

NOTE The Gear ratio object will not be used for Homing mode.

9.1.23 0x608F Position encoder resolution

This read only object indicates the configured encoder increments per number of motor revolutions. The information is read from the drive's encoder configuration.

Table 9-24 Position encoder resolution

0x608F Position encoder resolution			
Sub-index 0			
Access: RO	Range: N/A	Size: 1 byte	Unit: N/A
Default: 2	Type: USINT		
Description:			
Sub-index 1			
Access: RO	Range: 0 to 0xFFFFFFFF	Size: 4 bytes	Unit: N/A
Default: 65536	Type: UDINT		
Description: Encoder increments, derived from the normalization turns of the associate encoder channel			
Sub-index 2			
Access: RO	Range: N/A	Size: 4 bytes	Unit: N/A
Default: 1	Type: UDINT		
Description: Motor revolutions, always 1			

This read only object indicates the configured encoder increments per number of motor revolutions. The value is calculated from the normalization turns parameter as $2^{NormTurnsParam}$. The used parameter depends on the feedback source selected by the 0x3000 object and Pr.0.03.026 (Motor Control Feedback Select), as in Table 9-25. If the drive is set in Open Loop mode, or the encoder less mode is selected, both the encoder increments, and the motor revolutions values are set equal to 1.

The object is updated during the operating mode change. The update of the encoder resolution whilst a profile mode is in operational state is not supported and therefore advised against.

Table 9-25 Object 0x608F Normalization turns source parameter

Object 0x3000	Pr.0.03.026	Description	Normalized turns	
			Menu	Parameter
0	0	Drive P1 Source	3	57
	1	Drive P2 Source	3	157
	2	Option in slot 1 (P1)	15	57
	3	Option in slot 1 (P2)	25	157
	4	Option in slot 2 (P1)	16	57
	5	Option in slot 2 (P2)	26	157
	6	Option in slot 3 (P1)	17	57
	7	Option in slot 3 (P2)	27	157
1	-	Drive P1 Source	3	57
2		Drive P2 Source	3	157
3		Option in slot 1 (P1)	15	57
4		Option in slot 1 (P2)	25	157
5		Option in slot 2 (P1)	16	57
6		Option in slot 2 (P2)	26	157
7		Option in slot 3 (P1)	17	57
8		Option in slot 3 (P2)	27	157
11		Encoder less	-	

9.1.24 0x6091 Gear ratio

This object is used to apply scaling. When configured, appropriate user units can be used to control the position of the shaft beyond a gearbox. The gear ratio is calculated using the following formula:

$$\text{gear ratio} = \text{motor shaft revolutions} / \text{driving shaft revolutions}$$

Table 9-26 Gear ratio

0x6091		Gear ratio	
Sub-index 0			
Access: RO	Range: N/A	Size: 1 byte	Unit: N/A
Default: 2	Type: USINT		
Description:			
Sub-index 1			
Access: RW	Range: 0 to 0xFFFFFFFF	Size: 4 bytes	Unit: N/A
Default: 1	Type: UDINT		
Description: Motor revolutions			
Sub-index 2			
Access: RW	Range: 0 to 0xFFFFFFFF	Size: 4 bytes	Unit: N/A
Default: 1	Type: UDINT		
Description: Shaft revolutions			

9.1.25 0x6092 Feed constant

This is used to configure a feed constant. This is the measurement distance per one revolution of the output shaft of the gearbox. The feed constant is calculated using the following formula:

$$\text{feed constant} = \text{feed} / \text{driving shaft revolutions}$$

Table 9-27 Feed constant

0x6092		Feed constant	
Sub-index 0			
Access: RO	Range: N/A	Size: 1 byte	Unit: N/A
Default: 2	Type: USINT		
Description:			
Sub-index 1			
Access: RW	Range: 0 to 0xFFFFFFFF	Size: 4 bytes	Unit: N/A
Default: 65536	Type: UDINT		
Description: Feed			
Sub-index 2			
Access: RW	Range: 0 to 0xFFFFFFFF	Size: 4 bytes	Unit: N/A
Default: 1	Type: UDINT		
Description: Shaft revolutions			

9.1.26 0x60E3 Supported Homing Methods

0x60E3	Supported Homing Methods						Object type: ARRAY		
							Data type: INTEGER8		
Supported modes	pp	pv	vl	lp	hm	csp	csv	cst	
Sub-index 0	Name: NumberOf Entries								
Access: Const				Range: N/A			Unit: N/A		
				Data type: UNIIGNED8			Default: 32		
Description:	Highest sub-index supported								
Sub-index 1	Name: SupportedHomingMethod_1								
Access: Const				Range: N/A			Unit: N/A		
				Data type: INTEGER8			Default: 1		
Sub-index 2	Name: SupportedHomingMethod_2								
Access: Const				Range: N/A			Unit: N/A		
				Data type: INTEGER8			Default: 2		
To									
Sub-index N	Name: SupportedHomingMethod_N								
Access: Const				Range: N/A			Unit: N/A		
				Data type: INTEGER8			Default: 37		

Each sub index of the object 0x60E3 describes a supported homing method. See Homing section for further details.

9.1.27 0x60FB Profile Version

0x60FB	Position Control Par Set						Object type: RECORD		
Supported modes	pp	pv	vl	lp	hm	csp	csv	cst	
Sub-index 0	Name: NumberOf Entries								
Access: Const	PDO Map: No			Range: N/A			Unit: N/A		
				Data type: UNIIGNED8			Default: 2		
Description:	Highest sub-index supported								
Sub-index 1	Name: Kp								
Access: RW	PDO Map: RPDO			Range: 0 to 500000			Unit: see Pr.39.007		
				Data type: INTEGER8			Default: from see Pr.39.007		
				Handling rate: 40 ms					
Description:	Position controller proportional gain								
Sub-index 2	Name: Kvff								
Access: RW	PDO Map: RPDO			Range: 0 to 2000			Unit: See Pr.39.010		
				Data type: UNSIGNED			Default: from see Pr.39.010		
				Handling rate: 40 ms					
Description:	Position controller speed forward gain								

The sub index 1 and 2 of this object are used to configure the Pr.39.010 (AMC Position Control Loop Kp Gain) and 39.007 (AMC Speed Feed-forwards Gain) respectively. The parameters values are used to initialize the object on start-up, if the operating mode is changed or if the CiA402 profiles are re-enabled.

When the object is written by the user, the change is reflected in the parameters within 40 ms. Note that except when the object is initialized, any user change to the parameter have no effect on it: the user should not change the parameters when the CiA402 profiles are enabled.

9.1.28 0x67FE Supported Homing Methods

0x67FE	Profile Version					Object type: RECORD		
Supported modes	pp	pv	vl	lp	hm	csp	csv	cst
Sub-index 0			Range: N/A					
Access: Const			Data type: UNIIGNED32			Unit: N/A		
			Handling rate: N/A			Default: 0x03010000		
Description:	Version of the CiA402 profile							

This object provides the version number of the CiA402, which is implemented in the device, according to the format described by Table 9-28.

Table 9-28 Profile version data format

Byte	Definition		
MSB	3	0x03	Major version number for this profile specification version
	2	0x01	Minor version number for this profile specification version
	1	0x00	Minor version number for this profile specification version
LSB	0	0x00	Reserved

9.1.29 Supported drive modes

This object provides information on the supported drive modes.

Each bit of the 0x6502 object represent the support to a specific operating mode: if a bit value is 1 the relative mode is supported. This value is set only on reset, depending on the drive type and mode as it is specified by Table 9-30.

The reserved bits (4 and 11 to 15) and the manufacturer specific bits (16 to 31) are unused and they are always set to zero.

Table 9-29 Supported drive modes value definition

31-16	15-11	10	9	8	7	6	5	4	3	2	1	0
ms	r	csta	cst	csv	csp	ip	hm	r	tq	pv	vl	pp

Table 9-30 Supported drive modes depending on the drive type and value

Bit	Op. Mode	Drive type / mode							
		M600			M70x, M75x			C200, C300	
		RFC-S RFC-A	OL	Regen	RFC-S RFC-A	OL	Regen	RFC-A	OL
10	csta	0	0	0	0	0	0	0	0
9	cst	1	1	0	1	1	0	0	0
8	csv	0	0	0	1	0	0	0	0
7	csp	0	0	0	1	0	0	0	0
6	ip	0	0	0	1	0	0	0	0
5	hm	0	0	0	1	0	0	0	0
3	tq	0	0	0	0	0	0	0	0
2	pv	1	0	0	1	0	0	1	0
1	vl	1	1	0	1	1	0	1	1
0	pp	0	0	0	1	0	0	0	0
	Obj. value (hex)	00000204	00000202	00000000	00000000	00000202	00000000	00000004	00000002

9.2 vl velocity mode

The velocity mode is supported on all drive types and modes, except in regen modes. The drive's speed handling and ramps are always used; the data flow partially depends however on the drive type and mode, and the configured position feedback source where available

Figure 9-2 VL velocity mode (Open loop mode or C200, C300, M400 drives)

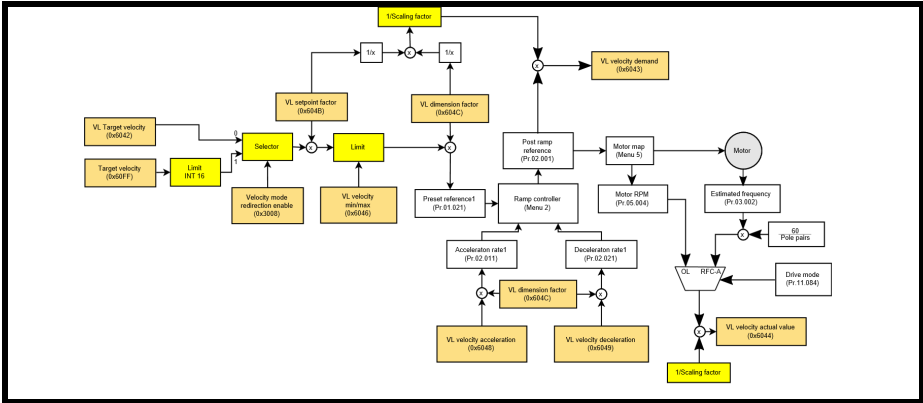

Figure 9-3 VL velocity mode (M600, M70x, M75x drives RFC-A, RFC-S modes)

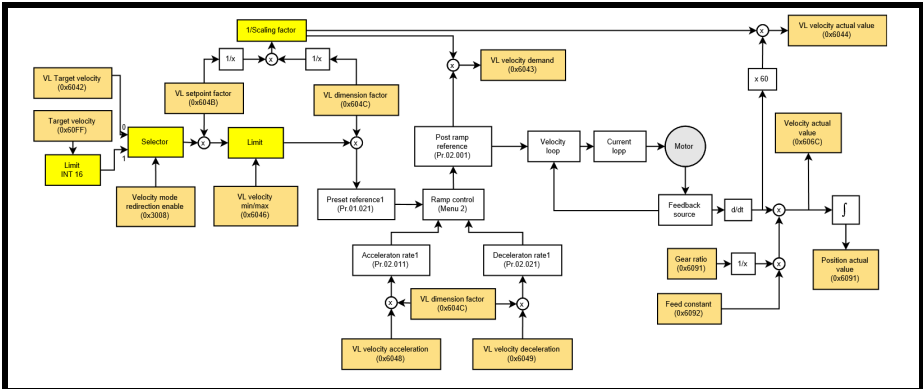

Table 9-31 lists the objects that are supported:

Table 9-31 vl velocity mode supported objects

Index	Name
0x3008	<i>Active velocity mode redirection</i>
0x6042	<i>vl_target_velocity</i>
0x6043	<i>vl_velocity_demand</i>
0x6044	<i>vl_velocity_actual_value</i>
0x6046	<i>vl_velocity_min_max_amount</i>
0x6048	<i>vl_velocity_accleration</i>
0x6049	<i>vl_velocity_deceleration</i>
0x604A	<i>vl_velocity_quick_stop</i>
0x604B	<i>vl_setpoint_factor</i>
0x604C	<i>vl_dimension_factor</i>

9.2.1 Activate velocity mode redirection

This object provides the facility to redirect the velocity mode reference from the normal velocity mode object (0x6042) to the cyclic sync velocity mode object (0x60FF).

Table 9-32 Activate velocity mode redirection

0x3008	Activate velocity mode redirection		
Sub-index 0			
Access: RW	Range: 0 to 1	Size: 1 byte	Unit: N/A
Default: 0	Type: USINT		
Description:	Redirects the velocity mode reference from object 0x6042 to object 0x60FF. Normally object 0x60FF is the reference for csv mode and object 0x6042 is the reference for velocity mode. Activating this object means that object 0x60FF will be used as the reference for velocity mode. Units are RPM in the range -32768 to 32767. This object value change will take effect on a CiA402 transition from "Ready to switch on" to "Switched on".		

9.2.2 0x6042 vl target velocity

This object is used to set the required velocity of the system. It is multiplied by the *vl_dimension_factor* and the *vl_setpoint_factor*. The value is given in rpm, if the *vl_dimension_factor* has the value of 1, otherwise the value is in user units. Positive values indicate forward direction and negative values indicate reverse direction.

Table 9-33 vl target velocity

0x6042	vl target velocity		
Sub-index 0			
Access: RW	Range: -32768 to +32767	Size: 2 bytes	Unit: rpm
Default: 0	Type: INT		
Description:	Used to set the required velocity of the system.		

9.2.3 0x6043 vl velocity demand

This read only object provides the instantaneous velocity demand generated by the drive ramp function. The value is given in rpm if the *vl_dimension_factor* and the *vl_setpoint_factor* have the value 1, otherwise the value is in user units. Positive values indicate forward direction and negative values indicate reverse direction.

Table 9-34 vl velocity demand

0x6043		vl velocity demand	
Sub-index 0			
Access: RO	Range: -32768 to +32767	Size: 2 bytes	Unit: rpm
Default: 0	Type: INT		
Description: Provides the instantaneous velocity demand generated by the drive ramp function.			

9.2.4 0x6044 vl velocity actual value

This read only object provides the velocity at the motor spindle or load. In a closed loop system this is determined from the motor feedback device and in an open loop system it is derived from the drive's estimated velocity.

The value is given in rpm if the *vl_dimension_factor* has the value of 1, otherwise the value is in user units. Positive values indicate forward direction and negative values indicate reverse direction.

Table 9-35 velocity actual value

0x6044		vl velocity actual value	
Sub-index 0			
Access: RO	Range: -32768 to +32767	Size: 2 bytes	Unit: N/A
Default: 0	Type: INT		
Description: Provides the velocity at the motor spindle or load.			

9.2.5 0x6046 vl velocity min max amount

This object is used to configure the minimum and maximum velocity.

The value is given in rpm if the *vl_dimension_factor* has the value of 1, otherwise the value is in user units.

Table 9-36 vl velocity min max amount

0x6046		vl velocity min max amount	
Sub-index 0			
Access: RO	Range: N/A	Size: 1 byte	Unit: N/A
Default: 2	Type: USINT		
Description: The number of sub-indices in this object.			
Sub-index 1			
Access: RW	Range: 0 to 40000	Size: 4 bytes	Unit: rpm
Default: 0	Type: UDINT		
Description: Used to configure the minimum velocity (both in the forward and reverse direction) that the system can operate at. Writing to this sub index will overwrite <i>vl_velocity_min</i> positive and <i>vl_velocity_min</i> negative.			
Sub-index 2			
Access: RW	Range: 0 to 40000	Size: 4 bytes	Unit: rpm
Default: 40000	Type: UDINT		
Description: Used to configure the maximum velocity (both in the forward and reverse direction) that the system can operate at. Writing to this sub index will overwrite <i>vl_velocity_max</i> positive and <i>vl_velocity_max</i> negative.			

9.2.6 0x6048 vl velocity acceleration

This object is used to configure the delta speed and delta time of the slope of the acceleration ramp.

Example: To ramp to 1000 rpm in 5 s, possible values for delta speed and delta time are 10000 and 50 respectively.

$$vl_velocity_acceleration = \text{delta speed} / \text{delta time}$$

Table 9-37 0x6048 vl velocity acceleration

0x6048		vl velocity acceleration	
Sub-index 0			
Access: RO	Range: N/A	Size: 1 byte	Unit: N/A
Default: 2	Type: USINT		
Description: The number of sub-indices in this object.			
Sub-index 1			
Access: RW	Range: 0 to 0xFFFFFFFF	Size: 4 bytes	Unit: rpm
Default: 1000	Type: UDINT		
Description: The value of delta speed is given in rpm if the <i>vl_dimension_factor</i> and the <i>vl_setpoint_factor</i> have the value 1, otherwise the value is in user units.			
Sub-index 2			
Access: RW	Range: 0 to 65535	Size: 2 bytes	Unit: s
Default: 2	Type: UINT		
Description: The value of delta time is given in seconds.			

9.2.7 0x6049 vl velocity deceleration

This object is used to configure the delta speed and delta time of the slope of the deceleration ramp.

Example: To decelerate by 800 rpm in 10 s, possible values for delta speed and delta time are 8000 and 100 respectively.

$$vl_velocity_deceleration = \text{delta speed} / \text{delta time}$$

Table 9-38 0x6049 vl velocity deceleration

0x6049		vl velocity deceleration	
Sub-index 0			
Access: RO	Range: N/A	Size: 1 byte	Unit: N/A
Default: 2	Type: USINT		
Description: The number of sub-indices in this object.			
Sub-index 1			
Access: RW	Range: 0 to 0xFFFFFFFF	Size: 4 bytes	Unit: rpm
Default: 1000	Type: UDINT		
Description: The value of delta speed is given in rpm if the <i>vl_dimension_factor</i> and the <i>vl_setpoint_factor</i> have the value 1, otherwise the value is in user units.			
Sub-index 2			
Access: RW	Range: 0 to 65535	Size: 2 bytes	Unit: s
Default: 2	Type: UINT		
Description: The value of delta time is given in seconds.			

9.2.8 0x604A vl velocity quick stop

This object is used to configure the delta speed and delta time of the slope of the deceleration ramp for quick stop.

Example: To decelerate by 800 rpm in 10 s, possible values for delta speed and delta time are 8000 and 100 respectively.

$$\text{vl velocity deceleration} = \text{delta speed} / \text{delta time}$$

Table 9-39 0x604A vl velocity quick stop

0x604A		vl velocity quick stop	
Sub-index 0			
Access: RO	Range: N/A	Size: 1 byte	Unit: N/A
Default:	2	Type: USINT	
Description:	The number of sub-indices in this object.		
Sub-index 1			
Access: RW	Range: 0 to 0xFFFFFFFF	Size: 4 bytes	Unit: rpm
Default:	1000	Type: UDINT	
Description:	The value of delta speed is given in rpm if the <i>vl_dimension_factor</i> and the <i>vl_setpoint_factor</i> have the value 1, otherwise the value is in user units.		
Sub-index 2			
Access: RW	Range: 0 to 65535	Size: 2 bytes	Unit: s
Default:	2	Type: UINT	
Description:	The value of delta time is given in seconds.		

9.2.9 0x604B vl setpoint factor

This object is used to configure the numerator and denominator of the *vl_setpoint_factor*. The *vl_setpoint_factor* modifies the resolution or directing range of the specified setpoint. It does not influence the velocity limit function and the ramp function. A value of 0 must not be used.

Table 9-40 0x604B vl setpoint factor

0x604B		vl setpoint factor	
Sub-index 0			
Access: RO	Range: N/A	Size: 1 byte	Unit: N/A
Default:	2	Type: USINT	
Description:	The number of sub-indices in this object.		
Sub-index 1			
Access: RW	Range: -32768 to +32767	Size: 2 bytes	Unit: N/A
Default:	1	Type: INT	
Description:	<i>vl_setpoint_factor</i> numerator (a value of 0 is not valid).		
Sub-index 2			
Access: RW	Range: -32768 to +32767	Size: 2 bytes	Unit: N/A
Default:	1	Type: INT	
Description:	<i>vl_setpoint_factor</i> denominator (a value of 0 is not valid).		

9.2.10 0x604C vl dimension factor

This object is used to configure the numerator and denominator of the *vl_dimension_factor*. The *vl_dimension_factor* is used to scale the user units so that they can be used in a way that relates to the specific application.

Calculating the vl dimension factor:

Every user-specific velocity consists of a specific unit referred to as a specific unit of time (e.g. 1/s, bottles/min, m/s,...). The purpose of the *vl_dimension_factor* is to convert this specific unit to the revolutions/minute unit. A value of 0 must not be used.

$$\text{Velocity [user-defined unit] / Dimension factor [rpm/user-defined unit]} = \text{Velocity [rpm]}$$

Table 9-41 0x604C vl dimension factor

0x604C		vl dimension factor	
Sub-index 0			
Access: RO	Range: N/A	Size: 1 byte	Unit: N/A
Default: 2		Type: USINT	
Description: The number of sub-indices in this object.			
Sub-index 1			
Access: RW	Range: -32768 to +32767	Size: 2 bytes	Unit: N/A
Default: 1		Type: INT	
Description: <i>vl_dimension_factor</i> numerator (a value of 0 is not valid).			
Sub-index 2			
Access: RW	Range: -32768 to +32767	Size: 2 bytes	Unit: N/A
Default: 1		Type: INT	
Description: <i>vl_dimension_factor</i> denominator (a value of 0 is not valid).			

The *vl_target_velocity* object is re-read every new profile cycle. It is scaled to appropriate units using the *vl_dimension_factor* and *vl_setpoint_factor* objects and then written to the drive preset reference 1 parameter (Pr **01.021**).

The object *vl_velocity_min_max* is handled every profile cycle. The *vl_target_velocity* is limited according to the values set in the object *vl_velocity_min_max*, which is read every profile cycle. The object *vl_velocity_min_max_amount* is mapped to *vl_velocity_min_max*.

The value of the *vl_velocity_demand* object is calculated in the background. The option reads the value of parameter Pr **02.001** (post ramp reference), scaled from RPM to user units using *vl_dimension_factor* and *vl_setpoint_factor*, and writes the value to the *vl_velocity_demand* object.

On a closed-loop drive, the speed feedback is calculated internally every profile cycle, scaled to the same units as *vl_target_velocity* and written to the *vl_velocity_actual_value* object. On an open-loop drive, the estimated motor speed is read from Pr **05.004** (motor RPM) in the background, scaled to the units of *vl_target_velocity* and written to the *vl_velocity_actual_value* object.

The *vl_velocity_acceleration* and *vl_velocity_deceleration* objects are handled in the background. They are read, scaled to drive acceleration units (depending on the drive operating mode), and written to the drive acceleration rate and deceleration rate presets. In addition, if the drive acceleration rate preset is changed, the *vl_velocity_acceleration* object is updated, and if the drive deceleration rate preset is changed (Pr **02.021**), the *vl_velocity_deceleration* object is updated.

9.3 Homing mode

This section describes the method by which a drive seeks the home position (also called, the datum, reference point or zero point).

Figure 9-4 shows the defined input objects as well as the output objects. The user may specify the speeds, acceleration and the method of homing. There is a further object named home offset, which allows the user to displace zero in the user's coordinate system from the home position.

There is no output data except for those bits in the statusword, which return the status or result of the homing process and the demand to the position control loops.

Figure 9-4 Homing mode function

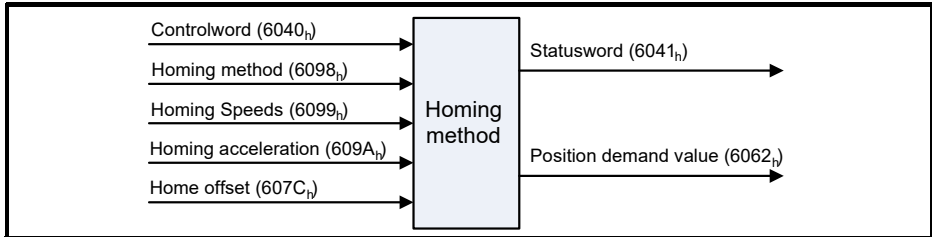

By choosing a homing method the following behavior is determined: The homing signal (home switch), the direction of actuation and where appropriate the position of the index pulse.

An encircled number in Figure 9-5 to Figure 9-10 indicates the code for selection of this homing position. The direction of movement is also indicated.

There are two sources of homing signal available: These are the home switch and the index pulse from an encoder.

9.3.1 General homing definitions

Method 3 and 4: Homing on positive home switch and index pulse

Using these methods as shown in Figure 9-5 *Homing on positive home switch and index pulse* on page 70, the initial direction of movement shall be dependent on the state of the home switch.

The home position shall be at the index pulse either to the left or the right of the point where the home switch changes state. If the initial position is sited so that the direction of movement shall reverse during homing, the point at which the reversal takes place is anywhere after a change of state of the home switch.

Figure 9-5 Homing on positive home switch and index pulse

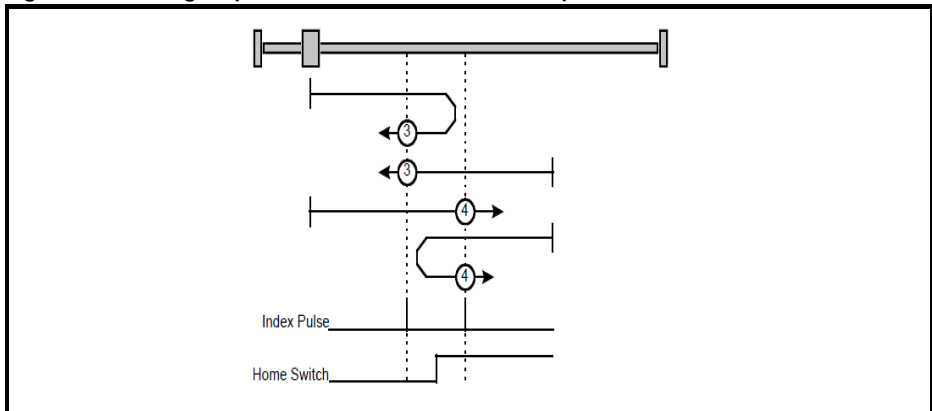

Method 5 and 6: Homing on negative home switch and index pulse

Using these methods as shown in Figure 9-6 *Homing on negative home switch and index pulse* on page 71, the initial direction of movement shall be dependent on the state of the home switch. The home position shall be at the index pulse either to the left or the right of the point where the home switch changes state. If the initial position is sited so that the direction of movement shall reverse during homing, the point at which the reversal takes place is anywhere after a change of state of the home switch.

Figure 9-6 Homing on negative home switch and index pulse

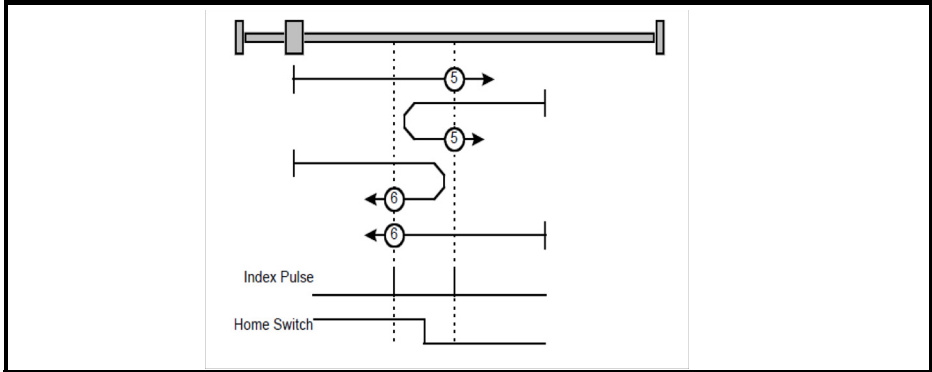

Method 7 to 14: Homing on home switch and index pulse

These methods use a home switch, which is active over only a portion of the travel; in effect the switch has a 'momentary' action as the axis's position sweeps past the switch. Using the methods 7 to 10, the initial direction of movement shall be to the right, and using methods 11 to 14 the initial direction of movement shall be to the left except if the home switch is active at the start of the motion. In this case the initial direction of motion shall be dependent on the edge being sought. The home position shall be at the index pulse on either side of the rising or falling edges of the home switch, as shown in Figure 9-7 *Homing on home switch and index pulse - positive initial motion* on page 72 and Figure 9-8 *Homing on home switch and index pulse - negative initial motion* on page 72. If the initial direction of movement leads away from the home switch, the drive shall reverse on encountering the relevant limit switch.

Figure 9-7 Homing on home switch and index pulse - positive initial motion

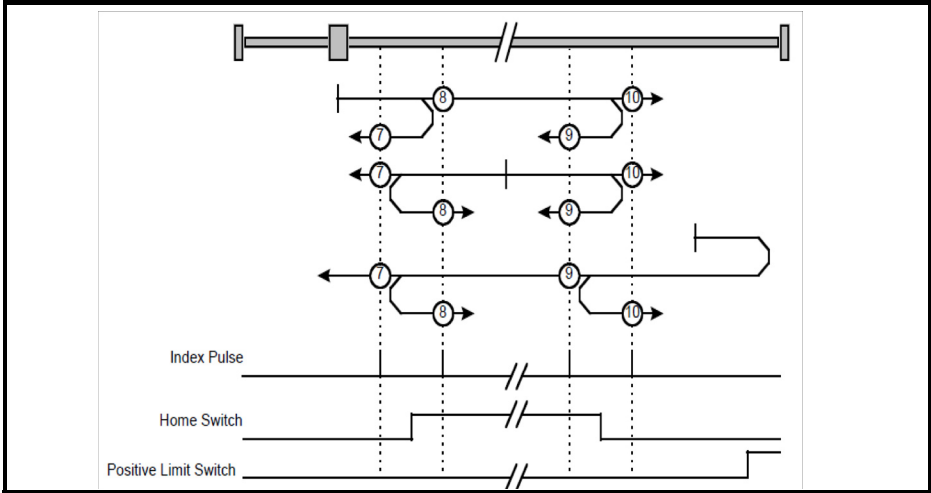
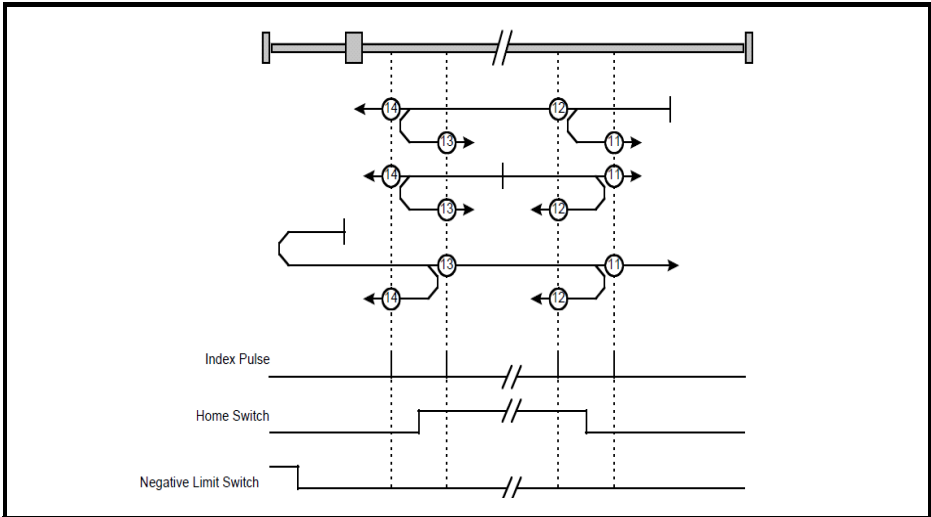

Figure 9-8 Homing on home switch and index pulse - negative initial motion



Method 15 and 16: Reserved

These methods are reserved.

Method 17 to 30: Homing without index pulse

These methods are similar to methods 3 to 14 except that the home position is not dependent on the index pulse but only dependent on the relevant home transitions. For example methods 19 and 20 are similar to methods 3 and 4 as shown in Figure 9-9 *Homing on positive home switch* on page 73.

Figure 9-9 Homing on positive home switch

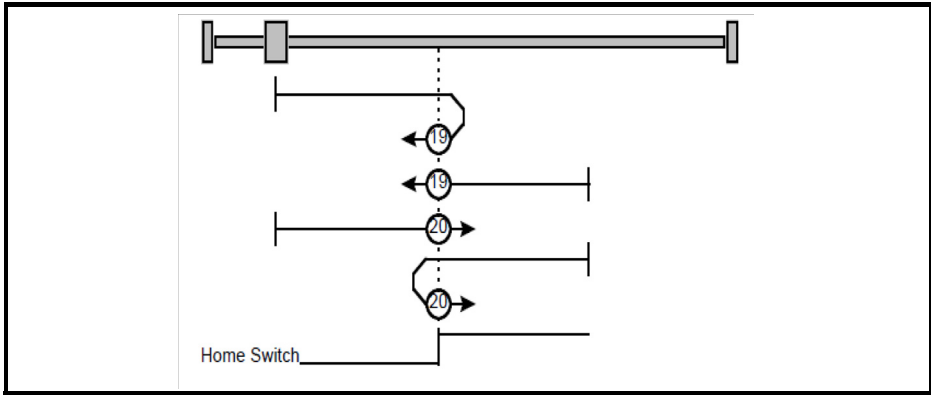

Method 31 and 32: Reserved

These methods are reserved.

Method 33 and 34: Homing on index pulse

Using these methods, the direction of homing is negative or positive respectively. The home position shall be at the index pulse found in the selected direction as shown in Figure 9-10 *Homing on index pulse* on page 73.

Figure 9-10 Homing on index pulse

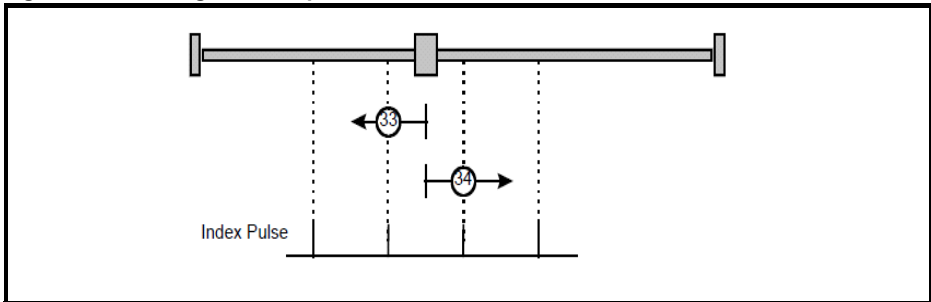

Method 35: Homing on the current position

In this method, the current position shall be taken to be the home position. This method does not require the drive device to be in operational enabled state.

Use of controlword and statusword

The homing mode uses some bits of the controlword and the statusword for mode-specific purposes. Table 9-42 *Definition of bits 4 and 8 of the controlword* on page 73 defines the values for bits 4 and 8 of the controlword.

Table 9-42 Definition of bits 4 and 8 of the controlword

Bit	Value	Definition
4	0	Do not start homing procedure.
	1	Start or continue homing procedure.
8	0	Enable bit 4.
	1	Stop Axis according to the configured Slow down or Quick stop ramp

Table 9-43 Definition of bits 10 and 12 of the statusword

Bit 12	Bit 10	Definition
0	0	Homing procedure is in progress.
0	1	Homing procedure is interrupted or not started.
1	0	Homing is attained, but target is not reached.
1	1	Homing procedure was completed successfully.
0	0	Homing error occurred, velocity is not 0.
0	1	Homing error occurred, velocity is 0.
1	X	Reserved.

9.3.2 Homing mode object definitions

0x3003 Homing source

This object indicates the configured source of the homing switch used during the homing procedure. Table 9-44 *Homing source REC* on page 74 specifies the object description.

Table 9-44 Homing source REC

0x3003		Homing source REC	
Sub-index 0			
Access: RO	Range: N/A	Size: 1 byte	Unit: N/A
Default:	2	Type: USINT8	
Description: The number of the last sub-index in this object.			
Sub-index 1			
Access: RW	Range: 1 to 6	Size: 1 byte	Unit: N/A
Default:	5	Type: USINT8	
Description: The source of homing switch. This will specify the number of a drive digital input/output; the selected DIO also needs to be configured as an input. This value will be read when CiA402 homing operation mode is selected.			
Sub-index 2			
Access: RW	Range: 0 to 2	Size: 1 byte	Unit: N/A
Default:	0	Type: USINT8	
Description: Freeze or marker source for homing; this value will be read when CiA402 homing operation mode is selected. This will have a value as follows: 0 - Use the marker of the feedback source selected for position feedback (see object 0x3000) 1 - Use the F1 freeze of the selected feedback source (drive or numbered option module). 2 - Use the F2 freeze of the selected feedback source (drive or numbered option module).			

0x607C Home offset

This object indicates the configured difference between the zero position for the application and the machine home position (found during homing). During homing the machine home position is found and once the homing is completed, the zero position is offset from the home position by adding the home offset to the home position. All subsequent absolute moves shall be taken relative to this new zero position. This is illustrated in Figure 9-11 *Home offset definition* on page 75. The value of this object shall be given in user-defined position units. Negative values indicate the opposite direction.

Figure 9-11 Home offset definition



Table 9-45 Home offset

0x607C		Home offset	
Sub-index 0			
Access: RW	Range: 0x80000000 to 0x7FFFFFFF	Size: 4 bytes	Unit: User-defined position units
Default: 0	Type: DINT		
Description: Homing offset value.			

0x6098 Homing method

This object indicates the configured homing method that shall be used. Table 9-46 *Homing method* on page 75 specifies the object description, and Table 9-47 *Homing method values* on page 75 specifies the value ranges for this object.

Table 9-46 Homing method

0x6098		Homing method	
Sub-index 0			
Access: RW	Range: 0 - 37	Size: 1 byte	Unit: N/A
Default: 0	Type: USINT		
Description: The homing method that shall be used.			

Table 9-47 Homing method values

Value	Definition
0	No homing method assigned
3	Method 3 shall be used
to	
34	Method 34 shall be used
35	Method 35 shall be used

0x6099 Homing speeds

This object indicates the configured speeds used during the homing procedure. The values shall be given in user-defined velocity units. Table 9-48 *Homing speeds* on page 76 specifies the object description.

Table 9-48 Homing speeds

0x6099 Homing speeds			
Sub-index 0			
Access: RO	Range: 2	Size: 1 byte	Unit: N/A
Default: 2		Type: USINT	
Description: The number of the last sub-index in this object.			
Sub-index 1			
Access: RW	Range: 0 to 0xFFFFFFFF	Size: 4 bytes	Unit: N/A
Default: 0		Type: UDINT	
Description: Speed during search for a switch.			
Sub-index 2			
Access: RW	Range: 0 to 0xFFFFFFFF	Size: 4 bytes	Unit: N/A
Default: 0		Type: UDINT	
Description: Speed during search for a zero.			

0x609A Homing acceleration

This object indicates the configured acceleration and deceleration to be used during the homing operation. The value shall be given in user-defined acceleration units. Table 9-49 *Homing acceleration* on page 76 specifies the object description.

Table 9-49 Homing acceleration

0x609A Homing acceleration			
Sub-index 0			
Access: RW	Range: 0 to 0xFFFFFFFF	Size: 4 bytes	Unit: User-defined acceleration units
Default: 65536		Type: UDINT	
Description: Indicates the configured acceleration and deceleration to be used during homing operation.			

9.4 Cyclic synchronous position mode (CSP)

The target position is fed through a linear interpolator to calculate a new position every 250 us; the obtained value can be then optionally filtered by a configurable moving average filter, by the setting of a not null value in the manufacturer specific object 0x300A. The interpolator is bypassed if the interpolation time period (0x60C2) is set equal to one network cycle but the filter, if enabled, remains in use. The new target position is applied to the interpolator input synchronous to the network cycle, so the interpolation period shall be equal to the network cycle or a multiple of it.

The linear interpolator, when enabled causes a delay of one operating mode cycle; an additional delay, depending on the window size is also introduced by the filter when enabled.

The data flow diagram of the internal implementation is represented in Figure 9-12. The AMC functionality is used to implement the CSP mode via the EGB block: the user can set the EGB ratio (Pr.37.002 and Pr.37.003) to provide an additional scaling. The EGB lock bands are set to the maximum allowed values to force the profile generator to be bypassed.

The AMC internal units correspond by default to the user units according to the scaling factor specified by the gear ratio and the feed constant (the 0x6091 and 0x6092 objects respectively); an additional power of 2 scaling can be however applied setting the 0x3009 object. The CSP mode is available only if the option module is fitted on a Unidrive M70x or Digitax M75x and they are configured in the RFC-A or RFC-S mode.

Figure 9-12 Cyclic synchronous position data flow

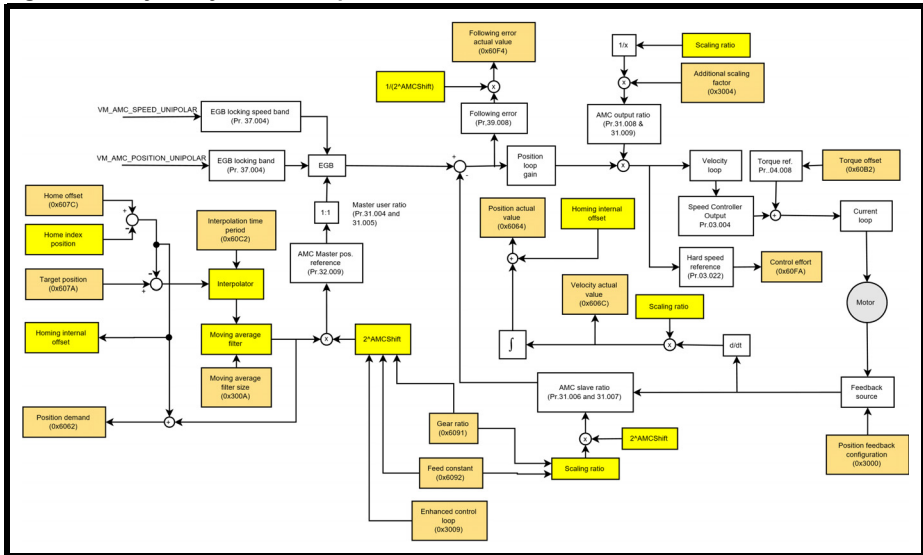

Table 9-50 Cyclic synchronous position statusword usage

Bit	Value	Definition
10	0	Reserved (always 0)
12	0	The drive does not follow the command value: the target position is ignored
	1	The drive follows the command value: the target position is used as input to position control loop
13	0	Following error lower than the threshold
	1	Following error above the threshold

Table 9-51 Cyclic sync position mode

Index	Name
0x607A	target_position
0x60C0	Interpolation sub-mode select
0x60C2	interpolation_time_period

9.4.1 0x607A Target_position

This object indicates the commanded position that the drive should move to in cyclic sync position mode using the current settings of motion control parameters such as velocity, acceleration, deceleration, motion profile type etc. The value of this object is given in user-defined position units.

Table 9-52 Target position

0x607A		TargetPosition I32						
Supported modes	pp	pv	vl	lp	hm	csp	csv	cst
Sub-index 0	Range: -2^{31} to $2^{31}-1$							
Access: RW	PDO Map: RPDO		Data type: INTEGER32			Unit: UU		
	Read rate: 250 μ s			Default: 0				
Description:	Indicates the command positions that the drive should move to in the cyclic sync position							

Table 9-53 Interpolation sub-mode select

0x60C0		Interpolation sub-mode select		
Sub-index 0				
Access: RW	Range: 0 to 0		Size: 2 bytes	Unit: N/A
Default:	0 (Linear Interpolation)		Type: INT	
Description:	This will specify the interpolation type. The values have the following meanings: 0 = Linear Interpolation.			

Table 9-54 Interpolation time period

0x60C2 Interpolation time period			
Sub-index 0			
Access: RO	Range: N/A	Size: 1 byte	Unit: N/A
Default: 2	Type: USINT		
Description: The number of the last sub-index in this object.			
Sub-index 1			
Access: RW	Range: 0 to 255	Size: 1 byte	Unit: (sub-index 2)
Default: 250	Type: USINT		
Description: The number of time units between interpolator restarts. A time unit is defined by sub-index 2. The interpolator time period value will be checked to ensure that it is valid. Valid values are 250 μ s, 500 μ s or any multiple of 1 ms. Selecting other values will result in an error indication.			
Sub-index 2			
Access: RW	Range: -6 to 0	Size: 1 byte	Unit: N/A
Default: -6 (a time unit of 1 μ s)	Type: SINT		
Description: This specifies the time unit for the interpolation time period. Sub-index 2 specifies the unit exponent. The time unit, therefore, is $10^{(\text{sub-index } 2)}$. The range of values allows for the shortest time unit to be 1 μ s, and the longest to be 1 s.			

Safety information
Introduction
Mechanical installation
Electrical installation
Getting started
Supported Objects
PDO, SDO & POWERLINK Modes
Object descriptions
Drive profile modes
Parameter descriptions
Diagnostics
Glossary of terms
Index

9.5 Cyclic synchronous velocity mode (CSV)

Cyclic Synchronous Velocity mode will be supported on Unidrive M600 and above in RFC-A and RFC-S operating modes.

The target velocity and the offset velocity (objects 0x60FF and 0x60B1) respectively are summed to provide the input of the linear interpolator that outputs a new setpoint velocity every 250 μ s. The output of the interpolator can be then optionally filtered by a configurable moving average filter, if a not null value is set in the manufacturer specific object 0x300A (see 4.3.2.7). The interpolator is bypassed if the interpolation time period (0x60C2) is set equal to one network cycle but the filter, if enabled, remains in use. The new velocity value is sampled by the interpolator every network cycle.

The linear interpolator, when enabled causes a delay of one operating mode cycle; an additional delay, depending on the window size is also introduced by the filter when enabled.

The data flow diagram of the internal implementation is represented in Figure 9-13. The AMC functionality is used to implement the CSV mode via the AMC speed reference. The AMC module is configured in speed mode (Pr.31.014 and Pr.34.007 are set to on and 2 respectively); in this configuration the AMC position error is forced to zero. The AMC acceleration and deceleration are set to the maximum allowed value to force the AMC output to follow the speed reference without ramp.

The AMC internal units correspond to the user units according to the scaling factor specified by the gear ratio and the feed constant (the 0x6091 and 0x6092 objects respectively). An additional scaling can be performed on the AMC output by the object 0x3004.

The CSV mode is available only if the option module is fitted on a Unidrive M70x or Digitax M75x and they are configured in the RFC-A or RFC-S mode.

Figure 9-13 Cyclic synchronous velocity mode data flow

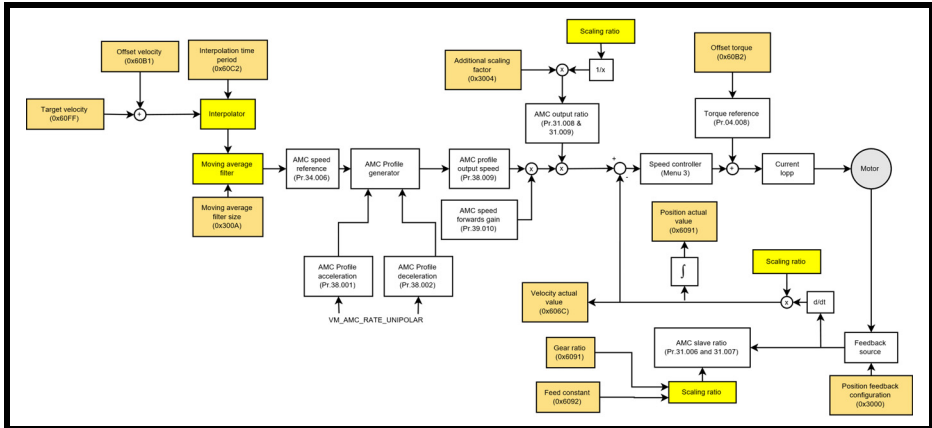

The CSV mode uses no mode-specific bits of the controlword and one bit of the statusword for mode-specific purposes (see Table 9-55).

Table 9-55 Cyclic synchronous velocity statusword usage

Bit	Value	Definition
10	0	Reserved (always 0)
12	0	The drive does not follow the command value: the target velocity is ignored
	1	The drive follows the command value: the target velocity is used as input to position control loop
13	0	Reserved (always 0)

Index	Name
606C	Velocity actual value
60B1	Velocity Offset
60C2	interpolation_time_period
60FF	target_velocity

The target_velocity object will be re-read every new profile cycle (as specified by the interpolation_time_period. This velocity demand will be scaled appropriately and written to the drive; interpolation will be used to generate additional intermediate values if the interpolation_time_period is greater than the interval at which the drive will read the hard speed reference parameter.

9.5.1 Velocity actual value

This object provides the facility to read the actual velocity feedback value.

Table 9-56 Velocity actual value

0x606C	Velocity actual value		
Sub-index 0			
Access: RO	Range: -2^{31} to $+2^{31}-1$	Size: 4 bytes	Unit: N/A
Default: 0	Type: DINT		
Description:	Indicates the actual velocity feedback value. Value is given in user-defined velocity unit.		

9.5.2 Target velocity

This object is used to specify the target velocity value. The value is given in user-defined units.

Table 9-57 Target velocity

0x60FF	Target velocity		
Sub-index 0			
Access: RW	Range: -2^{31} to $+2^{31}-1$	Size: 4 bytes	Unit: N/A
Default: 0	Type: DINT		
Description:	Specifies the target velocity value in user-defined velocity units.		

9.5.3 Velocity offset

This object is used to specify the velocity offset value. The value is given in user-defined units.

Table 9-58 Velocity offset

0x60B1		Velocity offset	
Sub-index 0			
Access: RW	Range: -2^{31} to $+2^{31}-1$	Size: 4 bytes	Unit: N/A
Default: 0	Type: DINT		
Description:	Specifies the velocity offset value in user-defined velocity units. The target velocity value is added to the velocity offset value to give the final velocity reference value.		

9.6 Cyclic synchronous torque mode (CST)

The CST mode is only available if the option module is fitted on a drive with synchronization capability (Unidrive M600, M70x or Digitax M75x).

The target torque is fed through a linear interpolator to calculate a torque set point every 250 μ s; the obtained value can be then optionally filtered by a configurable moving average filter, by the setting of a not null value in the manufacturer specific object 0x300A. The interpolator is bypassed if the interpolation time period (0x60C2) is set equal to one network cycle but the filter, if enabled, remains in use.

Figure 9-14 Cyclic synchronous torque data flow

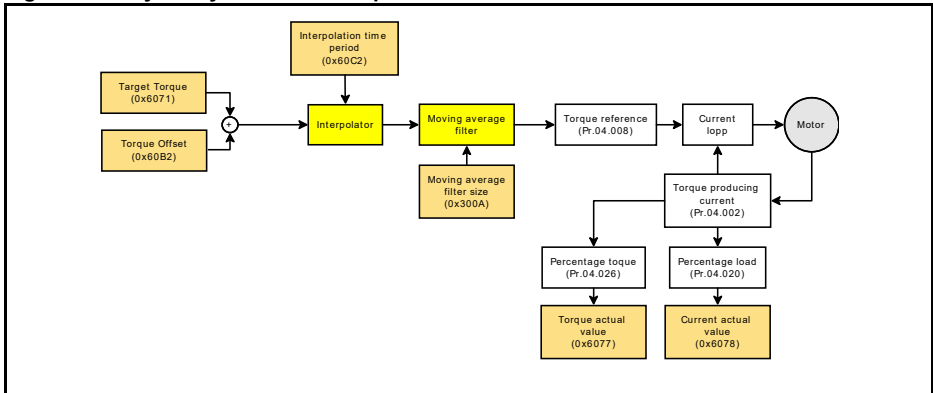

The CST mode uses no mode-specific bits of the controlword and one bit of the statusword for mode-specific purposes (see Table 9-59)

Table 9-59 Cyclic synchronous torque statusword usage

Bit	Value	Definition
10	0	Reserved (always 0)
12	0	The drive does not follow the command value: the target torque is ignored
	1	The drive follows the command value: the target torque is used as input to position control loop
13	0	Reserved (always 0)

The following objects will be supported:

Index	Name
6071	target_torque
6073	max_current
6075	motorRatedCurrent
6077	torqueActualValue
6078	Current actual value
60B2	Torque Offset
60C2	Interpolation_time_period

9.6.1 Target torque

This object is used to specify the target torque value. The value is given in user-defined units.

Table 9-60 Target torque

0x6071		Target torque	
Sub-index 0			
Access: RW	Range: -32768 to 32767	Size: 2 bytes	Unit: N/A
Default:	0	Type: INT	
Description:	Specifies the target torque value. Value is in 0.1 % units. (e.g. A value of 1000 equates to 100.00 % in Pr 04.008)		

9.6.2 Maximum current

This object is used to specify the maximum current value. The value is given in user-defined units.

Table 9-61 Maximum current

0x6073		Maximum current	
Sub-index 0			
Access: RW	Range: 0 to 65535	Size: 2 bytes	Unit: N/A
Default:	0	Type: UINT	
Description:	Specifies the maximum current value. Value is in 0.1 % units. (e.g. A value of 1000 equates to 100.0 % in Pr 04.007) This value is also changed when Pr 04.007 is written to.		

Safety information
Introduction
Mechanical installation
Electrical installation
Getting started
Supported Objects
PDO, SDO & POWERLINK Modes
Object descriptions
Drive profile modes
Parameter descriptions
Diagnostics
Glossary of terms
Index

9.6.3 Torque actual value

This object provides the actual instantaneous torque value. The value is given in user-defined units.

Table 9-62 Torque actual value

0x6077		Torque actual value	
Sub-index 0			
Access: RO	Range: -32768 to 32767	Size: 2 bytes	Unit: N/A
Default: 0	Type: INT		
Description:	Indicates the actual instantaneous torque value. Value is in 0.1 % units. (e.g. A value of 1000 equates to 100.0 % in Pr 04.003) For open-loop drives, this value is taken from Pr 04.026 , on closed-loop drives this value is taken from Pr 04.003 .		

9.6.4 Current actual value

This object provides the actual instantaneous current value. The value is given in user-defined units.

Table 9-63 Current actual value

0x6078		Current actual value	
Sub-index 0			
Access: RO	Range: -32768 to 32767	Size: 2 bytes	Unit: N/A
Default: 0	Type: INT		
Description:	Indicates the actual instantaneous current value. Value is in 0.1 % units. (e.g. A value of 1000 equates to 100.0 % in Pr 04.004)		

9.6.5 Torque offset

This object is used to specify the torque offset value. The value is given in user-defined units.

Table 9-64 Torque offset

0x60B2		Torque offset	
Sub-index 0			
Access: RW	Range: -32768 to 32767	Size: 2 bytes	Unit: N/A
Default: 0	Type: INT		
Description:	The torque offset is applied setting Pr. 0.04.008 (Torque Reference), provided that a supported operating mode is selected.		

9.7 Error Handling

The following objects will be provided to indicate an error condition:

Index	Name
1001	error_register
603F	error_code

Table 9-65 Error register

0x1001	Error register
Sub-index 0	
Access: RO	Range: 0 to 255
Size: 1 byte	Unit: N/A
Default: 0	Type: USINT
Description:	<p>A non-zero value in this object indicates that an error has occurred. The bit(s) set indicate the type of error present. The following bits will be supported:</p> <ul style="list-style-type: none"> 0: Generic error 1: Current 2: Voltage 3: Temperature <p>When an error is indicated in this object, the particular error code will be contained in object 0x603F (Error code).</p>

Table 9-66 Error code

0x603F	Error code
Sub-index 0	
Access: RO	Range: 0x0 to 0xFFFF
Size: 2 bytes	Unit: N/A
Default: 0	Type: UINT
Description:	<p>A non-zero value in this object indicates that an error has occurred. The value will be one of the codes described in the Error code table below.</p>

When the fault state is activated because of a drive trip, the error cause is reported in the 0x603F object. Table provides the correspondence between the error codes and the drive trips: each drive trip corresponds to only one error code, although one error code can represent multiple trip codes. The object 0x603F is automatically cleared when the fault condition is reset.

Safety information
Introduction
Mechanical installation
Electrical installation
Getting started
Supported Objects
PDO, SDO & POWERLINK Modes
Object descriptions
Drive profile modes
Parameter descriptions
Diagnostics
Glossary of terms
Index

Table 9-67 Error code definitions

Error code	Meaning	Corresponding drive trip code (if available)
0x0000	Error reset / No error	0 – None
0xFF01	Generic error	(Any trip code not elsewhere in table)
0x2300	Current, device output side	3 – OI ac
0x3130	Phase failure	32 – Phase Loss 98 - Out Phase Loss
0x2230	Short circuit/ground leakage (device internal)	5 – PSU 9 – PSU 24V 92 - Snubber OI
0x3210	DC link over-voltage	2 – Over Volts
0x3230	Load error	38 - Low Load
0x4310	Excess temperature drive	21 – OHT Inverter 22 – OHT Power 23 – OHT Control 27 – OHT dc bus 101 - OHT Brake
0x5112	"Supply low voltage" and "U2 = supply +24 V"	91 - User 24V
0x5200	Control device hardware	200 - Slot 1 Hardware Fault 203 - Slot 1 Not Fitted 204 - Slot 1 Different 205 - Slot 2 Hardware Fault 208 - Slot 2 Not Fitted 209 - Slot 2 Different 210 - Slot 3 Hardware Fault 213 - Slot 3 Not Fitted 214 - Slot 3 Different 250 - Slot 4 Hardware Fault 253 - Slot 4 Not Fitted 254 - Slot 4 Different 221 - Stored HF
0x5400	Power section	111 - Config P 220 - Power Data 223 - Rating Mismatch
0x5510	RAM	227 - Sub Array RAM Allocation
0x5530	Data storage (Non-volatile data memory)	31 – EEPROM Fail 36 – User Save 37 – Power Down Save
0x5430	Input stages	94 - Rectifier set up
0x5440	Contacts	226 - Soft Start
0x6010	Software reset (watchdog)	30 – Watchdog
0x6320	Parameter Error	199 - Destination 216 - Slot App Menu Crash 217 - App menu changed
0x7112	Brake chopper (over current brake chopper)	4 – OI Brake 19 – Brake R Too Hot
0x7113	Protective circuit break chopper	10 - Th Brake Res
0x7120	Motor	11 - Autotune 1 12 - Autotune 2 13 - Autotune 3 20 - Motor Too Hot

Error code	Meaning	Corresponding drive trip code (if available)
0x7122	Motor error or commutation malfunction	14 – Autotune 4 15 – Autotune 5 16 – Autotune 6 24 - Thermistor 25 - Th Short Circuit 33 - Resistance
0x7300	Sensor	17 - Autotune 7 162 to 163 – Encoder 12 to Encoder 13 176 – Name Plate 189 to 198 – Encoder 1 to Encoder 10 218 - Temp Feedback
0x7310	Speed	7 - Over speed
0x7500	Communication	90 - Power Comms 103 - Interconnect
0x7600	Data storage (external)	174 - Card Slot 175 – Card Product 177 – Card Boot 178 – Card Busy 179 – Card Data Exists 180 – Card Option 181 – Card Read Only 182 – Card Error 183 – Card No Data 184 – Card Full 185 – Card Access 186 – Card Rating 187 – Card Drive Mode 188 – Card Compare

9.8 Abort connection option code

Table 9-68 Abort connection option code

0x6007	Abort connection option code		
Sub-index 0	Range: 0...3		
Access: RW	Data type: INTEGER	Unit: N/A	
	Handling rate: 40 ms	Default: 1	
Description:	Configure the CiA402 behaviour on NMT state changes		

The user can configure the CiA402 behaviour when the NMT state is switched out the NMT_CS_OPERATIONAL state because of a direct request or a network error.

Table 9-69

Value	Definition
0	No action
1	Fault reaction according to the fault reaction option code (object 0x605E)
2	Immediate drive disable (disable voltage command)
3	Quick stop according to the quick stop option code (object 0x605A)

10 Parameter descriptions

It is intended that it is not necessary to use many option module parameters for POWERLINK setup or control of a drive; parameters are mostly provided for status and information. This means that a user will configure the motor and feedback in the usual way, using parameters, install an SI-POWERLINK option, and use CiA402 objects to control the drive from that point onwards. Although, with objects which correspond to drive parameters, it should be possible to perform all drive/motor/feedback configuration using the POWERLINK interface. The Node ID parameter S.00.031 will need to be set unless a default of 1 is used on a single CN network.

In the following descriptions, S means the option module slot number.

10.1 Internal menus

SI-POWERLINK provides parameters for configuration and information, these parameters are grouped into menus as shown in Table 10-1.

Table 10-1 SI-POWERLINK internal menus

Menu	Name	Description
S.0	Setup	Provides module information such as firmware version and serial number
S.1	POWERLINK	Provides information about the module's POWERLINK stack
S.9	Diagnostics	Provides general diagnostic parameters related to the hardware and the internal software status of the option module.

10.2 Parameter type codes

Table 10-2 lists the coding used for the parameter type in the subsequent parameter description tables.

Table 10-2 Parameter type codes

RW	Read / Write	RO	Read-only	Bit	Bit parameter	Txt	Text string	Date	Date parameter	Time	Time parameter
Chr	Character parameter	Bin	Binary parameter	IP	IP address	Mac	MAC address	Ver	Version number	SMP	Slot, menu, parameter
Num	Number parameter	DE	Destination	ND	No default value	RA	Rating dependant	NC	Non-copyable	PT	Protected
Fl	Filtered	US	User save	PS	Power-down save	BU	Bit default or unipolar				

10.3 Parameter descriptions

10.3.1 Menu 0 (Setup)

Table 10-3 Pr.S.00.001 Module ID

S.00.001	Module ID		
Short Description	Module identification		
Minimum	0	Maximum	65535
Default	436	Units	N/A
Type	16 bits volatile	Update Rate	Once on power up
Display Format	Standard	Decimal Places	0
Coding	BU, PT, NC, ND		

Table 10-4 Pr.S.00.002 Application Version

S.00.002		Application version	
Short Description	Application firmware version		
Minimum	0	Maximum	99999999
Default	N/A	Units	N/A
Type	32 bits volatile	Update Rate	Once on power up
Display Format	Version	Decimal Places	0
Coding	BU, PT, NC, ND		

Table 10-5 Pr.S.00.003 Hardware version

S.00.003		Hardware version	
Short Description	Hardware version		
Minimum	0	Maximum	655.35
Default	N/A	Units	N/A
Type	16 bits volatile	Update Rate	Once on power up
Display Format	Standard	Decimal Places	2
Coding	BU, PT, NC, ND		

Table 10-6 Pr.S.00.004 Serial number LS

S.00.004		Serial number LS	
Short Description	Least significant part of the serial number		
Minimum	0	Maximum	99999999
Default	N/A	Units	N/A
Type	32 bits volatile	Update Rate	Once on power up
Display Format	Lead zero pad	Decimal Places	2
Coding	BU, PT, NC, ND		

The module serial number is available as a pair of 32 bits values where Serial Number LS (S.MM.004) provides the least significant 8 decimal digits and Serial Number MS (S.MM.005) provides the most significant 8 decimal digits. The reconstructed serial number is ((MM.005* 10000000) + MM.004). For example, the serial number "0001234567898765" is stored as S.MM.005 = 12345 and S.MM.004 = 67898765.

Table 10-7 Pr.S.00.005 Serial number MS

S.00.005		Serial number MS	
Short Description	Most significant part of the serial number		
Minimum	0	Maximum	99999999
Default	N/A	Units	N/A
Type	32 bits volatile	Update Rate	Once on power up
Display Format	Standard	Decimal Places	2
Coding	BU, PT, NC, ND		

Table 10-8 Pr.S.00.006 Module status

S.00.006		Module status	
Short Description	Status of the option module		
Minimum	-2	Maximum	3
Default	0	Units	N/A
Type	8 bits volatile	Update Rate	Background
Display Format	Standard	Decimal Places	0
Coding	PT, NC, ND, TE		

Value	Text	Description
-2	Bootldr - Update	The bootloader is updating the flash memory
-1	Bootldr - Idle	The bootloader is waiting for commands
0	Initializing	The firmware is initializing
1	Ok	The firmware initialized, and no errors have been detected
2	Config	Reserved code for future use
3	Error	An error has occurred preventing the firmware from running correctly, a power cycle or a reset is required to attempt to restore the normal functionalities

Table 10-9 Pr.S.00.007 Reset

S.00.007		Reset	
Short Description	Perform a warm reset		
Minimum	0	Maximum	1
Default	0	Units	N/A
Type	1 bit volatile	Update Rate	Read in background Written to 0 on start-up
Display Format	Standard	Decimal Places	0
Coding	W, NC		

A warm reset is performed when this parameter is set; after the reset and it is cleared to zero during the initialization routines. The drive, and any other modules fitted to the drive are not be affected by the reset. If motion is currently be performed, and it is possible, the motor is ramped to a stop before the reset occurs.

Table 10-10 Pr.S.00.008 Default

S.00.008		Default	
Short Description	Restore the factory default		
Minimum	0	Maximum	1
Default	0	Units	N/A
Type	1 bit volatile	Update Rate	Read and cleared on reset
Display Format	Standard	Decimal Places	0
Coding	W, NC		

The parameter is set to "ON" when the module is reset, it causes the option module to return to its "Out of Box configuration" any settings stored on the module will be returned to their default values, including the object dictionary, if it is saved. This parameter is automatically cleared after the reset and the revert to the default values is completed.

Table 10-11 Pr.S.00.031 Node ID

S.00.031		Node ID	
Short Description	Configured Powerlink node ID		
Minimum	0	Maximum	239
Default	1	Units	N/A
Type	8 bits user save	Update Rate	Read on NMT_GS_RESET_CONFIGURATION
Display Format	Standard	Decimal Places	0
Coding	BU, W, PT		

The parameter configures the Powerlink node ID of the option module: the value shall be unique in the network, if not data error may occur and the network will fail to enter in the operating state.

This parameter is evaluated only during the start-up: to make effective the changed, the option module shall be reset. The handling depends on the drive where the option module is fitted. On Unidrive and Commander drives the value is directly applied the Powerlink stack and it is copied to **Pr.S.00.032** (4.9.1.10) and the 0x1F93:01 object (4.3.1.3.1).

According to the EPSG DS301 specifications, the node ID valid range is between 1 and 239; for compatibility with all drive types, the parameter can be however set to zero: this value shall be set only if the option module is fitted on a Digitax HD drive (see below), else the "Invalid node ID" trip will be signalled on reset.

If the option module is fitted on a Digitax HD drive, the behaviour depends on the parameter value:

- If a not null value is set, the same behaviour as for the Unidrive and Commander drives applies
- If a null value is set, the node ID is defined using the KI-Compact rotary switches (**Pr.11.017**): the selected ID is copied to **Pr.S.00.032** and the 0x1F93:01 object. If an invalid node ID (outside the 1 to 239 range) is selected or the KI-Compact display is not available, the drive is tripped with the "Invalid node ID" code and the corresponding state is set in **Pr.S.01.010** (4.9.2.6).

Table 10-12 Pr.S.00.032 Active node ID

S.00.032		Active node ID	
Short Description	Active node ID used by the Powerlink stack		
Minimum	1	Maximum	239
Default	N/A	Units	N/A
Type	8 bits volatile	Update Rate	Set on reset
Display Format	Standard	Decimal Places	0
Coding	BU, PT, NC, ND		

The value specified by **Pr.S.00.031** or the 0x1F93:02, or the KI-Compact rotary switches where available, is applied on reset to the Powerlink stack as unique node ID in the network. Then it is copied to this parameter during. See also 4.3.1.3.1 and 4.9.1.9.

Safety Information
Introduction
Mechanical Installation
Electrical Installation
Getting started
Supported Objects
PDO, SDO & POWERLINK Modes
Object descriptions
Drive profile modes
Parameter descriptions
Diagnostics
Glossary of terms
Index

Table 10-13 Pr.S.00.033 Disable motion profiles

S.00.033	Disable motion profiles		
Short Description	Prevent the option from controlling the drive motion functions		
Minimum	1	Maximum	1
Default	0	Units	N/A
Type	1-bit user save	Update Rate	Read every 40 ms
Display Format	Standard	Decimal Places	0
Coding	W		

To use the CiA402 motion profiles, this parameter shall be set to "OFF"; in this case the drive controlword and many other drive parameters related to the motor control are controlled by the option module and they should not be modified by the user. If this parameter is set to "ON", all drive parameters can be freely changed but the CiA402 specific objects will not be handled even if they are still mappable and accessible via SDO requests.

If the motor is running when the profiles are disabled, the fault reaction is activated: the profiles will be deactivated as soon the motor stops or immediately if the immediate disable fault reaction is configured.

Please note that the motion profiles are also disabled if the network state is not operational; in this condition, the **Pr.S.00.33** has no effects until the network returns in the operational state.

10.3.2 Menu 1 Powerlink

This menu provides information about the Powerlink and the parameters to control it.

Table 10-14 Pr.S.01.001 NMT state

S.01.001	NMT state		
Short Description	Actual Powerlink NMT state		
Minimum	0	Maximum	12
Default	0	Units	N/A
Type	8 bits volatile	Update Rate	Background
Display Format	Standard	Decimal Places	0
Coding	PT, NC, TE		

Displays the actual NMT state of the device according to Table 10-15

Table 10-15 NMT state coding

Value	Display String	Corresponding Powelink NMT State
0	"Stack Init"	Not available: the stack is initializing
1	"Off"	NMT_GS_OFF
2	"Init"	NMT_GS_INITIALISING
3	"Reset App"	NMT_GS_RESET_APPLICATION
4	"Reset Comm"	NMT_GS_RESET_COMMUNICATION
5	"Reset Cfg"	NMT_GS_RESET_CONFIGURATION
6	"Not Active"	NMT_CS_NOT_ACTIVE
7	"PreOp1"	NMT_CS_PRE_OPERATIONAL_1
8	"PreOp2"	NMT_CS_PRE_OPERATIONAL_2
9	"ReadyToOp"	NMT_CS_READY_TO_OPERATE
10	"Op"	NMT_CS_OPERATIONAL
11	"Stop"	NMT_CS_STOPPED
12	"BasicETH"	NMT_CS_BASIC_ETHERNET

Table 10-16 Pr.S.01.002 PDO accesses per second

S.01.002		PDO accesses per second	
Short Description	Number of PDO handled per second		
Minimum	0	Maximum	65535
Default	0	Units	N/A
Type	16 bits volatile	Update Rate	Every 2s in background
Display Format	Standard	Decimal Places	0
Coding	BU, PT, NC		

The parameter counts the number of the handled PDO second, in both directions. For example, if there are two active RPDOs with valid mappings, the TPDO contains at least one mapping and the network cycle time is set to 250 μ s, this parameter will contain a value of 12000; the value may fluctuate slightly because it is not updated synchronously with the accesses.

Table 10-17 Pr.S.01.005 Mapped parameter xx.00

S.01.005		Mapped Parameter xx.000	
Short Description	Value which is mapped to parameter mm.000		
Minimum	0	Maximum	65535
Default	0	Units	N/A
Type	16 bits volatile	Update Rate	Background
Display Format	Standard	Decimal Places	0
Coding	BU, PT, NC		

The drive or options parameters can be accessed via the objects in the 0x2000 to 0x24FF range via SDO or PDO mappings. The subindex number normally correspond to a parameter number in a menu; it is however reserved to specify the highest parameter number in the menu (highest subindex number) so the mm.000 would be not accessible. The **Pr.S.01.003** mirrors the mm.000 to allow also the parameter 0 to be accessed via Powerlink. The **Pr.00.000** and **Pr.S.01.005** are checked in background for changes: if one value is changed, it is copied to the other; the 00.000 is evaluated first to be prioritized over the **Pr.01.004** changes.

Table 10-18 Pr.S.01.010 Status

S.01.010		Status	
Short Description	Current status of the Powerlink stack		
Minimum	-4	Maximum	5
Default	0	Units	N/A
Type	8 bits volatile	Update Rate	Background
Display Format	Standard	Decimal Places	0
Coding	PT, NC, ND, TE		

S.01.010 is a diagnostic parameter to indicate the actual state of the Powerlink application: no network functionalities are available if the status is not between "PreOperational" and "Run".

If an error is detected (the parameter value is negative, the Powerlink functionalities are not available: a reset is required to attempt to restore them.

Value	Display String	Description
-3	"Internal error"	Unexpected error detected
-2	"FPGA fail"	Communication hardware failure
-1	"Invalid node ID"	The selected node ID is invalid (only Digitax HD drives)

Value	Display String	Description
0	"Init"	Initialization in progress
1	"PreOperational"	Cyclic data exchange disabled
2	"Sync"	Drive synchronization in progress (only on Unidrive M600/M70x and Digitax HD drives)
3	"Ready"	Ready to handle cyclic data
4	"Run"	Cyclic data exchange is running
5	"Off"	The network functionalities are stopped

11 Diagnostics

11.1 Diagnostic parameters

11.1.1 Menu 9 Diagnostics

This menu contains general diagnostic parameters related to the hardware and the internal software status of the option module.

Table 11-1 Pr.S.09.001 SoC loss counter

S.09.001	SoC loss counter		
Short Description	SoC frame loss cumulative error counter		
Minimum	0	Maximum	$2^{32}-1$
Default	0	Units	N/A
Type	32 bits volatile	Update Rate	Background
Display Format	Standard	Decimal Places	0
Coding	BU, PT, NC		

This parameter displays the number of the SoC lost frames: it is a copy of the value in the 0x1C0B:01 object (see 4.3.1.9.1). It can be reset setting Pr.S.09.008 to "On" or setting the object 0x1C0B:01 to zero.

Table 11-2 Pr.S.09.002 PReq loss counter

S.09.002	PReq loss counter		
Short Description	PReq frame loss cumulative error counter		
Minimum	0	Maximum	$2^{32}-1$
Default	0	Units	N/A
Type	32 bits volatile	Update Rate	Background
Display Format	Standard	Decimal Places	0
Coding	BU, PT, NC		

This parameter displays the number of the PReq lost frames: it is a copy of the value in the 0x1C0D:01 object (see 04.3.1.9.1). It can be reset setting Pr.S.09.008 to "On" or setting the object 0x1C0D:01 to zero.

Table 11-3 Pr.S.09.003 CRC errors

S.09.003	CRC errors		
Short Description	Invalid frame CRC cumulative error counter		
Minimum	0	Maximum	$2^{32}-1$
Default	0	Units	N/A
Type	32 bits volatile	Update Rate	Background
Display Format	Standard	Decimal Places	0
Coding	BU, PT, NC		

This parameter displays the number of the discarded Powerlink frames because of an invalid CRC frames is received: it is a copy of the value in the 0x1C0F:01 object (see 4.3.1.9.3). It can be reset setting Pr.S.09.008 to "On" or setting the object 0x1C0F:01 to zero.

Table 11-4 Pr.S.09.004 Invalid frame error counter

S.09.004	CRC errors		
Short Description	Invalid Powerlink frames counter		
Minimum	0	Maximum	$2^{32}-1$
Default	0	Units	N/A
Type	32 bits volatile	Update Rate	Background
Display Format	Standard	Decimal Places	0
Coding	BU, PT, NC		

This parameter displays the number the received Powerlink frames with an invalid format. According to the EPSG DS301 specifications, this error causes an immediate NMT transition to the NMT_GS_RESET_COMMUNICATION state. The counter can be reset setting the Pr.S.09.008 to "On".

Table 11-5 Pr.S.09.005 Sync loss error counter

S.09.005	Sync loss error counter		
Short Description	Sync loss cumulative counter		
Minimum	0	Maximum	232-1
Default	0	Units	N/A
Type	32 bits volatile	Update Rate	Background
Display Format	Standard	Decimal Places	0
Coding	BU, PT, NC		

This parameter displays the number of times synchronisation of the module with the Powerlink network has been lost. The counter can be reset setting the Pr.S.09.009 to "On".

Table 11-6 Pr.S.09.006 SoC loss error level

S.09.006	SoC loss error level		
Short Description	SoC frame loss error level		
Minimum	0	Maximum	100
Default	0	Units	%
Type	8 bits volatile	Update Rate	Background
Display Format	Standard	Decimal Places	0
Coding	BU, PT, NC		

This parameter displays the percentage ratio between the SoC frame loss events counted by the 0x1C0B:02 object and the relative threshold set by the 0x1C0B:03 object (see 4.3.1.9.1). The NMT state is forced to NMT_CS_PRE_OPERATIONAL_1 when the threshold is reached (the parameter value is 100), according to the EPSG DS301 specifications.

Table 11-7 Pr.S.09.007 PReq loss error level

S.09.007		PReq loss error level	
Short Description	PReq frame loss error level		
Minimum	0	Maximum	100
Default	0	Units	%
Type	8 bits volatile	Update Rate	Background
Display Format	Standard	Decimal Places	0
Coding	BU, PT, NC		

This parameter is like Pr.S.09.001 but it refers to the PReq frames loss events, and it is calculated from the values of the 0x1C0D:02 and 0x1C0D:03 objects.

Table 11-8 Pr.S.09.008 CRC error level

S.09.008		CRC error level	
Short Description	Invalid frame CRC error level		
Minimum	0	Maximum	100
Default	0	Units	%
Type	8 bits volatile	Update Rate	Background
Display Format	Standard	Decimal Places	0
Coding	BU, PT, NC		

This parameter is similar to Pr.S.09.001 but it refers to the discarded frames loss due to an invalid CRC is received, and it is calculated from the values of the 0x1C0F:02 and 0x1C0F:03 objects.

Table 11-9 Pr.S.09.009 Reset error counters

S.09.009		CRC error level	
Short Description	Reset the Powerlink cumulative error counters		
Minimum	0	Maximum	1
Default	0	Units	
Type	1 bit volatile	Update Rate	Background Auto reset
Display Format	Standard	Decimal Places	0
Coding	BU, PT, NC, W		

This parameter resets all Powerlink cumulative error counters (Pr.S.09.001, Pr.S.09.002, Pr.S.09.003 and the sub index 1 of the objects 0x1C0B, 0x1C0D, 0x1C0F).

Table 11-10 Pr.S.09.025 Synchronization error

S.09.025		Synchronization error	
Short Description	Actual synchronization error		
Minimum	-32768	Maximum	32767
Default	N/A	Units	ns
Type	16 bits volatile	Update Rate	Background
Display Format	Standard	Decimal Places	0
Coding	PT, NC, ND		

This parameter is available only on Unidrive M600/M70x and Digitax HD M75x; it reports the synchronization error expressed in nanoseconds, between the drive control cycle and the Powerlink sync signal, corresponding to the Start of Cycle (SoC) frame sent by the MN.

Table 11-11 S.09.026 Maximum synchronization error

S.09.026		Maximum synchronization error	
Short Description	Maximum synchronization error		
Minimum	-32768	Maximum	32767
Default	-32768	Units	ns
Type	16 bits volatile	Update Rate	Background
Display Format	Standard	Decimal Places	0
Coding	PT, NC, ND		

This parameter shows the worst maximum synchronization error expressed in nanoseconds; it is reset to the minimum representable value (-32768) during the device start-up and when the NMT state switches to NMT_GS_RESET_APPLICATION. The parameter value is always zero if the option module is fitted on the Unidrive M400 and Commander C200/C300 drives.

Table 11-12 S.09.027 Minimum synchronization error

S.09.027		Minimum synchronization error	
Short Description	Maximum synchronization error		
Minimum	-32768	Maximum	32767
Default	32768	Units	ns
Type	16 bit volatile	Update Rate	Background
Display Format	Standard	Decimal Places	0
Coding	PT, NC, ND		

This parameter shows the worst minimum synchronization error expressed in nanoseconds; it is reset to the maximum representable value (32767) during the device start-up and when the NMT state switches to NMT_GS_RESET_APPLICATION. The parameter value is always zero if the option module is fitted on the Unidrive M400 and Commander C200/C300 drives.

Table 11-13 Pr.S.09.030 PCB temperature

S.09.030		PCB temperature	
Short Description	Measured temperature		
Minimum	-128	Maximum	127
Default	N/A	Units	°C
Type	8 bits volatile	Update Rate	Background
Display Format	Standard	Decimal Places	0
Coding	PT, NC, ND		

This parameter shows the temperature measured on the PCB surface, expressed in Celsius degrees.

11.2 Error handling

The following objects are provided to indicate an error condition

Table 11-14 Error handling objects

Index	Name
0x1001	Error_register
0x603F	Error_code

11.2.1 Error register

Table 11-15 Error register

0x1001		Error register		
Sub-index 0	Range: 0 to 255	Size: Unsigned 8	Unit: N/A	
Access: RO	Data type: UNSIGNED8		Unit: 0 -> 255	
	Handling rate: 40 ms		Default: 0	
Description: Active errors bitmask				

If a drive trip condition occurs, the error is notified in this object setting the bits described in Table 11-16. The error register can be reset by clearing the CiA402 fault condition. A more detailed error code can be read from the 0x603F .

No errors are signalled by this object if the CiA402 profiles are disable by Pr.S.00.034.

Table 11-16 0x1001 Error register bits

ERR-ErrorRegister_U8 value		Drive trip	
Bit	Description	Code	Name
0	Generic error	-	Any other not listed trip
1	Current	3	OI ac
		4	OI Brake
		5	PSU
		8	User OI ac (C200, C300, M400 only)
		9	PSU 24V (M600, M70x, M75x only)
		26	I/O overload
		28	An Input 1 Loss
		29	An Input 2 Loss
		38	Low Load (M600, M70x, M75x only)
		92	OI Snubber
		109	OI dc (M600, M70x, M75x only)
		189	An Input 1 OI (C200, C300, M400 only)
		190	An Input 2 OI (C200, C300, M400 only)
		191	An Input 3 OI (C200, C300, M400 only)
2	Voltage	225	Current Offset (M600, M70x, M75x only)
		2	Over Volts
		91	User 24 V
		169	Voltage Range

ERR-ErrorRegister_U8 value		Drive trip	
Bit	Description	Code	Name
3	Temperature	10	Th Brake Res
		19	Brake R Too Hot
		20	Motor Too Hot
		21	OHT Inverter
		22	OHT Power
		23	OHT Control (M600, M70x, M75x only)
		24	Thermistor
		25	Th Short Circuit
		27	OHT dc bus
		93	Inductor Too Hot (M600, M70x, M75x only)
		101	OHT Brake (M600, M70x, M75x only)
		102	OHT rectifier
		218	Temp Feedback (C200, C300, M400 only)
		219	OHT Control (C200, C300, M400 only)
250	Hot Rect/Brake		
20	Motor Too Hot		
4	Communication error (unused)	-	-
5	Device profile specific (unused)	-	-
6	Reserved (always 0)	-	-
7	Manufacturer specific (unused)	-	-

11.2.2 Error code

Table 11-17 Error code

0x603F	Error code		
Access: RO	Range: 0 to 0xFFFF	Size: 2 bytes	Unit: N/A
Default:	0		
Description:	A non-zero value in this object indicates that an error has occurred. The value will be one of the codes described in Table 11-18 below.		

11.3 Drive trip display codes

Table shows the possible trip codes that will be displayed on the drive when SI-POWERLINK initiates a drive trip.

Table 11-18 Trip errors

Code	Display text	Description
101	FPGA	Unexpected FPGA reset
102	Invalid FPGA Ver	The FPGA version is not compatible with the software
104	PLnk Stack Err	An internal Powerlink stack error has occurred
105	PLnk CRC Err	The invalid CRC counter has reached the limit threshold
106	PLnk PReq Loss	The PReq frames loss counter has reached the limit threshold
107	PLnk SoC Loss	The SoC frames loss counter has reached the limit threshold
108	PLnk Frame Err	Invalid Powerlink frame received
110	NMT No Op	The managing node switched the NMT state to a not Operative state
115	Sync Fail	Drive synchronisation lost
116	FPGA update	FPGA update failed
213	Over Temperature	The device is overheated
221	Factory settings	The factory setting file is missing

Table 11-19 Warning errors

Code	Display text	Description
1	Too hot	The temperature is over the warning limit
3	Sync Fail	Drive synchronisation lost
4	NMT No Op	The managing node switched the NMT state to a not Operative state
5	PLnk CRC Err	The invalid CRC counter has reached the limit threshold
6	PLnk PReq Loss	The PReq frames loss counter has reached the limit threshold
7	PLnk SoC Loss	The SoC frames loss counter has reached the limit threshold
8	PLnk Frame Err	Invalid Powerlink frame received

11.4 Updating SI-POWERLINK firmware

The latest SI-POWERLINK firmware is available from your local Control Techniques Drive Centre or supplier. To upload firmware to SI-POWERLINK a copy of the Control Techniques PC tool Connect and a suitable communications lead for the option module's host drive is required.

Safety information
Introduction
Mechanical installation
Electrical installation
Getting started
Supported Objects
PDO, SDO & POWERLINK Modes
Object descriptions
Drive profile modes
Parameter descriptions
Diagnostics
Glossary of terms
Index

11.5 Switching frequency

In applications where greater synchronization is required, it is suggested that the drive's automatic switching frequency option is switched off. If automatic frequency switching is required, then the network will continue to operate, however the synchronization jitter may increase for a short time when the switching frequency changes. To disable the drive's automatic switching frequency control, set the drive Pr **05.035** to Disabled (1)

11.6 SDO abort codes

SDO messages use a request-response mechanism and POWERLINK Managing Node (Master) will always expect a response from the Controlled Node (Slave) device. If an error occurs with an SDO transfer SI-POWERLINK will return an SDO abort code to indicate the reason for the failure, the SDO abort codes are listed in Table 11-20.

Table 11-20 SDO abort codes

Abort code (in hex.)	Description
0x05030000	Toggle bit not alternated
0x05040000	SDO protocol timed out
0x05040001	Client/server command specifier not valid or unknown
0x05040002	Invalid block size (block mode only)
0x05040003	Invalid sequence number (block mode only)
0x05040004	CRC error (block mode only)
0x05040005	Out of memory
0x06010000	Unsupported access to an object
0x06010001	Attempt to read a write only object
0x06010002	Attempt to write a read only object
0x06020000	Object does not exist in the object dictionary
0x06040041	Object cannot be mapped to the PDO
0x06040042	The number and length of the objects to be mapped would exceed PDO length
0x06040043	General parameter incompatibility
0x06040047	General internal incompatibility in the device
0x06060000	Access failed due to a hardware error
0x06070010	Data type does not match, length of service parameter does not match
0x06070012	Data type does not match, length of service parameter too high
0x06070013	Data type does not match, length of service parameter too low
0x06090011	Sub-index does not exist
0x06090030	Value range of parameter exceeded (only for write access)
0x06090031	Value of parameter written too high
0x06090032	Value of parameter written too low
0x06090036	Maximum value is less than minimum value
0x08000000	General error
0x08000020	Data cannot be transferred or stored to the application
0x08000021	Data cannot be transferred or stored to the application because of local control
0x08000022	Data cannot be transferred or stored to the application because of the present device state
0x08000023	Object dictionary dynamic generation fails or no object dictionary is present

12 Glossary of terms

Address: This is the unique network identification given to a networked device to allow communication on a network. When a device sends or receives data the address is used to determine the source and the destination of the message.

AMC: Advanced Motion Controller. Control Technique's parametrised motion controller integrated within the M70x and M75x drives.

Bit: A binary digit, this may have the value of 1 or 0.

Byte: A collection of eight binary digits that collectively store a value. This may be signed or unsigned.

CN: Controlled Node. A POWERLINK device such as SI-POWERLINK that acts as a "slave".

Control word: A collection of binary digits that are used to control the drive. Features typically include directional controls, run controls and other similar functions.

Cyclic: Data that is transmitted at regular intervals over the network.

Data rate: Determines the communication speed of the network, the higher the value the more data can be sent across the network in the same time period.

Device: A piece of equipment connected to a network, this may be any type of equipment including repeaters, hubs, masters (Managing Node) or slaves (Controlled Nodes).

Double word: A 32-bit word, this may be signed or unsigned.

EPSC: Ethernet POWERLINK Standardization Group

Grounding / Earthing: Describes the electrical safety or shielding connections for the module.

LED: Light emitting diode.

Long word: A 32-bit data word that may be signed or unsigned.

LSB: Least significant bit/byte.

MN: Managing Node: A POWERLINK "master" device.

MSB: Most significant bit/byte.

Note: A device on the network. This may be either a device such as a drive or part of the network such as a repeater.

Non cyclic data: Data that is requested or sent as required and not on a regular basis.

Octet: A collection of eight binary digits which form a byte.

PC: Personal computer.

Safety information
Introduction
Mechanical installation
Electrical installation
Getting started
Supported Objects
PDO, SDO & POWERLINK Modes
Object descriptions
Drive profile modes
Parameter descriptions
Diagnostics
Glossary of terms
Index

PLC: Programmable logic controller.

Poll rate: The rate at which cyclic data is sent and received on the network.

Polled data: See *Cyclic data*.

Scan rate: See *Poll rate*.

Shielding: A connection to provide additional immunity to noise used on a network cable.

Status word: A value that denotes the status of the drive. Each bit within the word will have a specific meaning.

Word: A collection of sixteen binary digits.

Index

A	
Address	103
B	
Bit	103
Byte	103
C	
Cautions	6
Control word	103
Cyclic data	103
Cyclic sync position mode	77
Cyclic Synchronous Velocity Mode	80
D	
Data rate	103
Device	103
Diagnostics	95
Double word	103
E	
Earthing / grounding	103
Electrical installation	16
Electrical safety	6
Error handling	98
F	
Features	11
G	
Getting started	21
Glossary of terms	103
H	
Homing mode	69
I	
Installation	13
Introduction	10
L	
LED	103
Long word	103
LSB	103
M	
Mechanical installation	13
MSB	103
N	
Node	103
Non cyclic data	103

Safety information
Introduction
Mechanical installation
Electrical installation
Getting started
Supported Objects
PDO, SDO & POWERLINK Modes
Object descriptions
Drive profile modes
Parameter descriptions
Diagnostics
Glossary of terms
Index

O	
Octet	103
Option module	11
P	
Parameter descriptions	88
PC	103
PLC	104
Poll rate	104
Polled data	104
Products covered by this User Guide	10
Q	
Quick start guide	21
S	
Safety information	6
Scan rate	104
Shielding	104
SI-POWERLINK Object Dictionary	28
Status word	104
Supported objects	27
V	
vI velocity mode	64
W	
Word	104



0478-0617-01