

Unidrive M600-M70X, F300, H300, E200 & E300 Size 3 Braking Resistor Installation Sheet

1 Safety information



Stored charge

The drive contains capacitors that remain charged to a potentially lethal voltage after the AC supply has been disconnected. If the drive has been energized, the AC supply must be isolated at least ten minutes before work may continue. Refer to section 3.1 Safety information in the User Guide.



The heatsink and heatsink mounted braking resistor can reach temperatures in excess of 70 °C (158 °F). Human contact with the heatsink and heatsink braking resistor should be restricted.



To avoid the risk of fire when the drive is surface mounted with the braking resistor installed, the backplate should be made from a non-flammable material.

2 Introduction

This braking resistor has been especially designed to be mounted within the heatsink of the Unidrive M600 / M70X, F300, H300, E200 & E300 size 3. The design of the resistor is such that no thermal protection circuit is required, as the device will fail safely under fault conditions. The in built software overload protection is set-up at default to protect the braking resistor.

Contents of the box (1220-2752-01)

The following items are supplied in the box:

- 1 x 75 Ω Brake resistor assembly
- 2 x Cable crimps
- 1 x Installation sheet

3 Installation

Step 1: Removing the terminal covers

Figure 1-1 Removing the AC and DC terminal covers

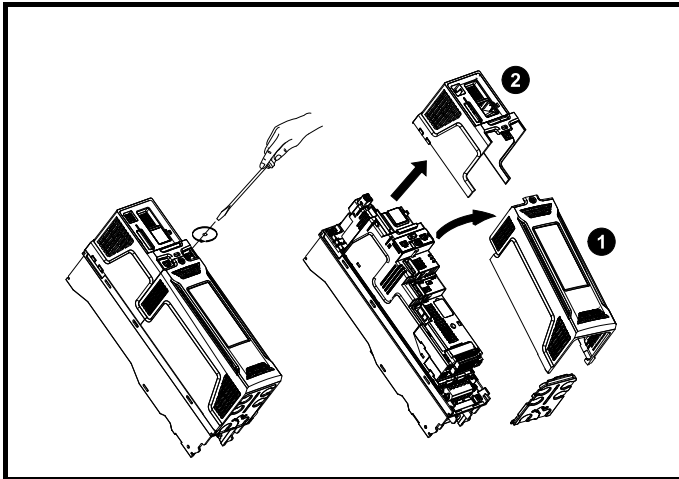

- To remove the terminal covers, undo the screw and remove the covers in direction shown above (Figure 1-1).
- The AC terminal cover (1) must be removed prior to the DC terminal cover (2).
- When replacing the terminal covers the screw should be tightened to a maximum torque of 1 N m (9 lb in).

Step 2: Removing the internal EMC filter

Figure 1-2 Removing the internal EMC filter

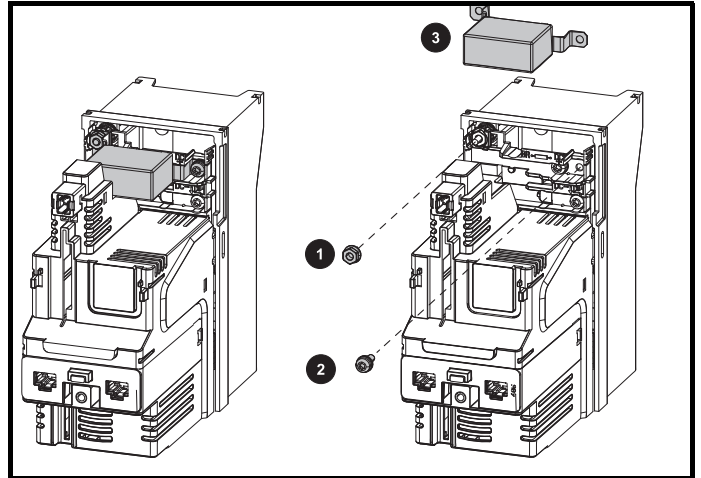

The internal EMC filter needs to be removed to establish brake resistor electrical connections. To remove the internal EMC filter:

- Loosen / remove the screw and nut as shown (1) and (2)
 - Lift away from securing points and then rotate away from the drive (3).
- Ensure the screw and nut are replaced and re-tightened with a maximum torque of 2 N m (18 lb in).

Step 3: Preparing for installation

Figure 1-3 Removing the brake resistor bung

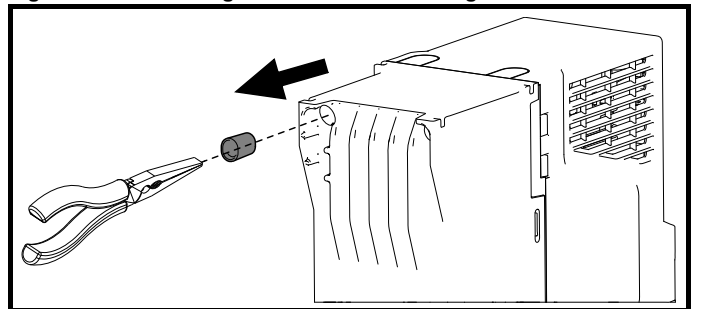

Remove the brake resistor bung from the hole in the chassis as shown above. The cap at the closed end of the bung will need to be removed, see Figure 1-4.

Figure 1-4 Removing the bung cap (end with lug on)

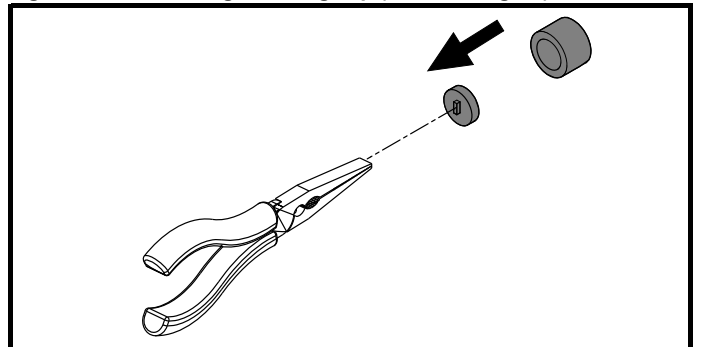

Remove the end of the bung with the lug on by piercing with a pair of long nose pliers and pulling out in the direction shown above to leave a hollow bung so that the cable can be routed through.



0478-0015-05

Figure 1-5 Inserting the brake resistor cable through the bung

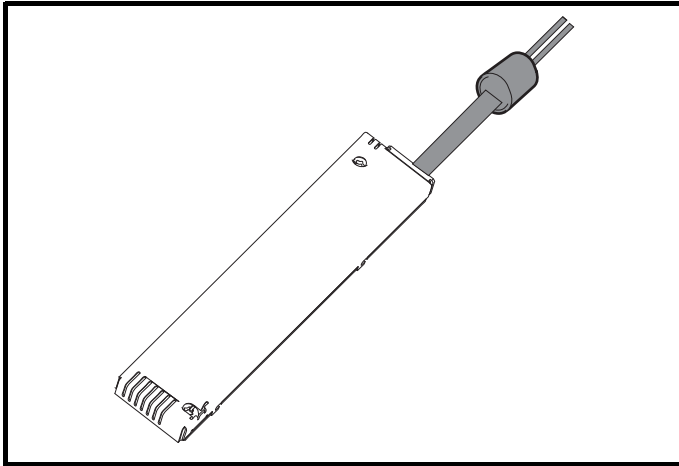

- Feed the brake resistor bung on to the outer insulation of the brake resistor cable. The wider end of the bung should be inserted first. The narrow end should then align with the end of insulation.

Step 4: Secure the braking resistor

Figure 1-6 Installing the brake resistor

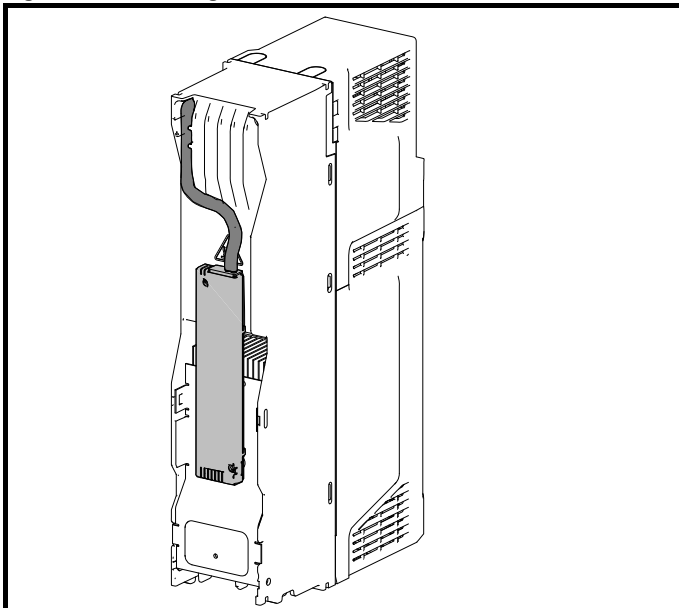

- Secure the braking resistor using captive M4 (x2) screws as shown above. The screws should be tightened to a maximum torque of 2 N m (18 lb in).
- Route the brake resistor cable and bung through the hole on the top left corner of the drive as shown above (Figure 1-6). The bung should penetrate as far as possible into the hole. Ensure the cables are routed between the fins of the heatsink, and the cables are not trapped between the heatsink fins and the resistor.
- Cut 70 mm (2.76 in) length off from one of the cables. Strip about 10 mm (0.39 in) of insulation from both of the cables and terminate the cables with the crimps provided.

Step 5: Establishing brake resistor electrical connections

Figure 1-7 Electrical connections

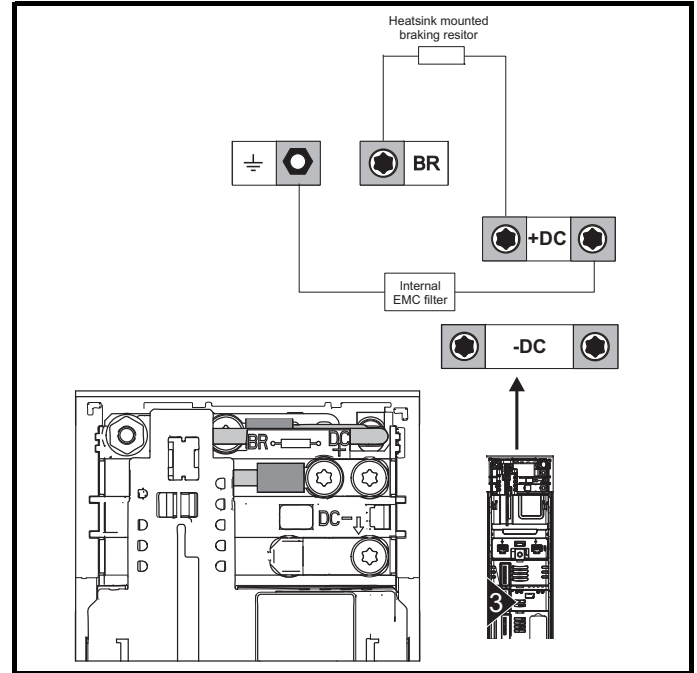

- Connect the brake resistor cables to BR and +DC terminals as shown above. Tighten the screw terminals to a maximum torque of 1.5 N m (13.5 lb in).
- Replace the internal EMC Filter. When replacing the EMC filter the screw and nut should be tightened to a maximum torque of 1.5 N m (13.5 lb in).
- Replace both terminal covers. When replacing the terminal covers the screw should be tightened to a maximum torque of 1 N m (9 lb in).



Failure to observe the following information may damage the resistor.

Parameter settings

Fan speed should be set to a maximum (Pr 06.045 to 11). The drive software contains an overload protection function for a braking resistor. On size 3 this function is enabled at default to protect the heatsink mounted braking resistor. Below are the parameter settings.

Parameter		Size 3	
		200V Drive	400V Drive
Braking Resistor Rated Power	Pr 10.030	50 W	
Braking Resistor Thermal Time Constant	Pr 10.031	3.3 s	
Braking Resistor Resistance	Pr 10.061	75 Ω	

For more information on the braking resistor software overload protection, see the *Parameter Reference Guide*.

Resistor specification

Parameter	Value
DC resistance at 25 °C	75 Ω
Peak instantaneous power over 1 ms at nominal resistance	8 kW
Average power over 60 s	50 W
Ingress Protection (IP) rating	IP54
Maximum altitude	2000 m

