



All for dreams



Frame 3 to 4 ***Power Installation Guide***

Unidrive M600 to ***M702 and HS70 to*** ***HS72***

Part Number: 0478-0254-07
Issue: 7

Original Instructions

For the purposes of compliance with the EU Machinery Directive 2006/42/EC, the English version of this manual is the Original Instructions. Manuals in other languages are Translations of the Original Instructions.

Documentation

Manuals are available to download from the following locations: <http://www.drive-setup.com/ctdownloads>

The information contained in this manual is believed to be correct at the time of printing and does not form part of any contract. The manufacturer reserves the right to change the specification of the product and its performance, and the contents of the manual, without notice.

Warranty and Liability

In no event and under no circumstances shall the manufacturer be liable for damages and failures due to misuse, abuse, improper installation, or abnormal conditions of temperature, dust, or corrosion, or failures due to operation outside the published ratings. The manufacturer is not liable for consequential and incidental damages. Contact the supplier of the dive for full details of the warranty terms.

Environmental policy

Control Techniques Ltd operates an Environmental Management System (EMS) that conforms to the International Standard ISO 14001.

Further information on our Environmental Policy can be found at: <http://www.drive-setup.com/environment>

Restriction of Hazardous Substances (RoHS)

The products covered by this manual comply with European and International regulations on the Restriction of Hazardous Substances including EU directive 2011/65/EU and the Chinese Administrative Measures for Restriction of Hazardous Substances in Electrical and Electronic Products.

Disposal and Recycling (WEEE)



When electronic products reach the end of their useful life, they must not be disposed of along with domestic waste but should be recycled by a specialist recycler of electronic equipment. Control Techniques products are designed to be easily dismantled into their major component parts for efficient recycling. The majority of materials used in the product are suitable for recycling.

Product packaging is of good quality and can be re-used. Large products are packed in wooden crates. Smaller products are packaged in strong cardboard cartons which have a high recycled fibre content. Cartons can be re-used and recycled. Polythene, used in protective film and bags for wrapping the product, can be recycled. When preparing to recycle or dispose of any product or packaging, please observe local legislation and best practice.

REACH legislation

EC Regulation 1907/2006 on the Registration, Evaluation, Authorisation and restriction of Chemicals (REACH) requires the supplier of an article to inform the recipient if it contains more than a specified proportion of any substance which is considered by the European Chemicals Agency (ECHA) to be a Substance of Very High Concern (SVHC) and is therefore listed by them as a candidate for compulsory authorisation.

Further information on our compliance with REACH can be found at: <http://www.drive-setup.com/reach>

Registered Office

Nidec Control Techniques Ltd
The Gro
Newtown
Powys
SY16 3BE
UK

Registered in England and Wales. Company Reg. No. 01236886.

Copyright

The contents of this publication are believed to be correct at the time of printing. In the interests of a commitment to a policy of continuous development and improvement, the manufacturer reserves the right to change the specification of the product or its performance, or the contents of the guide, without notice.

All rights reserved. No parts of this guide may be reproduced or transmitted in any form or by any means, electrical or mechanical including photocopying, recording or by an information storage or retrieval system, without permission in writing from the publisher.

Copyright © December 2022 Nidec Control Techniques Ltd

Contents

1	Safety information	9
1.1	Warnings, Cautions and Notes	9
1.2	Important safety information. Hazards. Competence of designers and installers	9
1.3	Responsibility	9
1.4	Compliance with regulations	9
1.5	Electrical hazards	10
1.6	Stored electrical charge	10
1.7	Mechanical hazards	10
1.8	Access to equipment	10
1.9	Environmental limits	10
1.10	Hazardous environments	11
1.11	Motor	11
1.12	Mechanical brake control	11
1.13	Adjusting parameters	11
1.14	Electromagnetic compatibility (EMC)	11
2	Product information	12
2.1	Introduction	12
2.2	Model number	12
2.3	Nameplate description	13
2.4	Ratings	14
2.5	Drive features	16
2.6	Items supplied with the drive	17
3	Mechanical installation	18
3.1	Safety information	18
3.2	Planning the installation	19
3.3	Terminal cover removal	21
3.4	Dimensions and mounting methods	24
3.5	Enclosure for standard drives	28
3.6	Enclosure design and drive ambient temperature	33
3.7	Heatsink fan operation	33
3.8	Enclosing standard drive for high environmental protection	33
3.9	Installation of high IP insert for size 3 and 4	35
3.10	Size 3 and 4 internal braking resistor	38
3.11	External EMC filter	42
3.12	Terminal size and torque settings	44
3.13	Routine maintenance	45
4	Electrical installation	46
4.1	Power and ground connections	47
4.2	AC Supply requirements	49
4.3	Supplying the drive with DC	51
4.4	DC bus paralleling	52
4.5	24 Vdc supply	53
4.6	Low voltage operation	54
4.7	Fan power supply	54
4.8	Ratings	54
4.9	Output circuit and motor protection	55
4.10	Braking	58
4.11	Ground leakage	63
4.12	EMC (Electromagnetic compatibility)	64
5	Technical data	77
5.1	Drive technical data	77
5.2	Optional external EMC filters	97

6	UL Information	99
6.1	UL file reference	99
6.2	Option modules, kits and accessories	99
6.3	Enclosure ratings	99
6.4	Mounting	99
6.5	Environment	100
6.6	Electrical Installation	100
6.7	Motor overload protection and thermal memory retention	101
6.8	External Class 2 supply	101
6.9	Modular Drive Systems	101

Declaration of Conformity

Control Techniques Ltd
The Gro
Newtown
Powys
UK
SY16 3BE

This declaration applies to the Unidrive M/HS product range comprising model numbers listed below:

Model number	Interpretation	Nomenclature aaaa - bbc ddddde
X	Application	M = Manufacturing Automation, E = Elevator, F = Flow, H = HVAC, CSD = Compressor, EVC = Emerson Variable Scroll, HS = High Speed
aaaa	Basic series	M100, M101, M200, M201, M300, M400, M600, M700, M701, M702, F300, H300, E200, E300, CSD1, HS30, HS70, HS71, HS72, M000, RECT
bb	Frame size	01, 02, 03, 04, 05, 06, 07, 08, 09, 10, 11
c	Voltage rating	1 = 100 V, 2 = 200 V, 4 = 400 V, 5 = 575 V, 6 = 690 V
dddd	Current rating	Example 01000 = 100 A
e	Drive format	A = 6P Rectifier + Inverter (internal choke), D = Inverter, E = 6P Rectifier + Inverter (external choke), N = 18P Rectifier + Inverter, T = 12P Rectifier + Inverter

The model number may be followed by additional characters that do not affect the ratings.

The variable speed drive products listed above have been designed and manufactured in accordance with the following European harmonized standards:

EN 61800-5-1:2007	Adjustable speed electrical power drive systems - Part 5-1: Safety requirements - Electrical, thermal and energy
EN 61800-3: 2004	Adjustable speed electrical power drive systems - Part 3: EMC requirements and specific test methods
EN 61000-6-2:2005	Electromagnetic compatibility (EMC) - Part 6-2: Generic standards - Immunity for industrial environments
EN 61000-6-4:2007	Electromagnetic compatibility (EMC) - Part 6-4: Generic standards - Emission standard for industrial environments
EN 61000-3-2:2006	Electromagnetic compatibility (EMC) - Part 3-2: Limits for harmonic current emissions (equipment input current ≤ 16 A per phase)
EN 61000-3-3:2008	Electromagnetic compatibility (EMC) - Part 3-3: Limitation of voltage changes, voltage fluctuations and flicker in public, low voltage supply systems, for equipment with rated current ≤ 16 A per phase and not subject to conditional connection

EN 61000-3-2: 2006 Applicable where input current < 16 A. No limits apply for professional equipment where input power ≥ 1 kW.

These products comply with the Restriction of Hazardous Substances Directive - RoHS 2011/65/EU, the Low Voltage Directive - LVD 2006/95/EC and the Electromagnetic Compatibility Directive - EMC 2004/108/EC.



G Williams
Vice President, Technology
Date: 30th November 2015

These electronic drive products are intended to be used with appropriate motors, controllers, electrical protection components and other equipment to form complete end products or systems. Compliance with safety and EMC regulations depends upon installing and configuring drives correctly, including using the specified input filters. The drives must be installed only by professional installers who are familiar with requirements for safety and EMC. The assembler is responsible for ensuring that the end product or system complies with all the relevant laws in the country where it is to be used. Refer to the Product Documentation. An EMC data sheet is also available giving detailed EMC information.

Declaration of Conformity (including 2006 Machinery Directive)

Control Techniques Ltd
The Gro
Newtown
Powys
UK
SY16 3BE

This declaration applies to the Unidrive M/HS product range comprising model numbers listed below:

Model number	Interpretation	Nomenclature aaaa - bbc dddddd
X	Application	M = Manufacturing Automation, E = Elevator, F = Flow, H = HVAC, CSD = Compressor, EVC = Emerson Variable Scroll, HS = High Speed
aaaa	Basic series	M300, M400, M600, M700, M701, M702, F300, H300, E200, E300, CSD1, HS30, HS70, HS71, HS72, M000, RECT
bb	Frame size	01, 02, 03, 04, 05, 06, 07, 08, 09, 10, 11
c	Voltage rating	1 = 100 V, 2 = 200 V, 4 = 400 V, 5 = 575 V, 6 = 690 V
dddd	Current rating	Example 01000 = 100 A
e	Drive format	A = 6P Rectifier + Inverter (internal choke), D = Inverter, E = 6P Rectifier + Inverter (external choke), N = 18P Rectifier + Inverter, T = 12P Rectifier + Inverter

The model number may be followed by additional characters that do not affect the ratings.

This declaration relates to these products when used as a safety component of a machine. Only the Safe Torque Off function may be used for a safety function of a machine. None of the other functions of the drive may be used to carry out a safety function.

These products fulfil all the relevant provisions of the Machinery Directive 2006/42/EC and the EMC Directive 2014/108/EC.

EC type examination has been carried out by the following notified body:

TUV Rheinland Industrie Service GmbH
Am Grauen Stein
D-51105 Köln
Germany

Notified body identification number: 0035

The harmonized standards used are shown below:

EC type-examination certificate numbers:

01/205/5270.01/14 dated 2014-11-11

01/205/5387.01/15 dated 2015-01-29

01/205/5383.02/15 dated 2015-04-21

EN 61800-5-1:2007	Adjustable speed electrical power drive systems - Part 5-1: Safety requirements - Electrical, thermal and energy
EN 61800-5-2:2007	Adjustable speed electrical power drive systems - Part 5-2: Safety requirements - Functional
EN ISO 13849-1:2008	Safety of Machinery, Safety-related parts of control systems, General principles for design
EN ISO 13849-2:2008	Safety of machinery, Safety-related parts of control systems. Validation
EN 61800-3: 2004	Adjustable speed electrical power drive systems - Part 3: EMC requirements and specific test methods
EN 62061:2005	Safety of machinery, Functional safety of safety related electrical, electronic and programmable electronic control systems

Person authorised to complete the technical file:

C Hargis

Chief Engineer

Newtown, Powys, UK



G Williams
Vice President, Technology

Date: 30th November 2015

IMPORTANT NOTICE

These electronic drive products are intended to be used with appropriate motors, controllers, electrical protection components and other equipment to form complete end products or systems. It is the responsibility of the installer to ensure that the design of the complete machine, including its safety-related control system, is carried out in accordance with the requirements of the Machinery Directive and any other relevant legislation. The use of a safety-related drive in itself does not ensure the safety of the machine.

Compliance with safety and EMC regulations depends upon installing and configuring drives correctly, including using the specified input filters. The drive must be installed only by professional installers who are familiar with requirements for safety and EMC. The assembler is responsible for ensuring that the end product or system complies with all relevant laws in the country where it is to be used. For more information regarding Safe Torque Off, refer to the *Control User Guide*.

1 Safety information

1.1 Warnings, Cautions and Notes



A Warning contains information which is essential for avoiding a safety hazard.



A Caution contains information which is necessary for avoiding a risk of damage to the product or other equipment.

NOTE

A **Note** contains information, which helps to ensure correct operation of the product.

1.2 Important safety information. Hazards. Competence of designers and installers

This guide applies to products which control electric motors either directly (drives) or indirectly (controllers, option modules and other auxiliary equipment and accessories). In all cases the hazards associated with powerful electrical drives are present, and all safety information relating to drives and associated equipment must be observed.

Specific warnings are given at the relevant places in this guide.

Drives and controllers are intended as components for professional incorporation into complete systems. If installed incorrectly they may present a safety hazard. The drive uses high voltages and currents, carries a high level of stored electrical energy, and is used to control equipment which can cause injury. Close attention is required to the electrical installation and the system design to avoid hazards either in normal operation or in the event of equipment malfunction. System design, installation, commissioning/start-up and maintenance must be carried out by personnel who have the necessary training and competence. They must read this safety information and this guide carefully.

1.3 Responsibility

It is the responsibility of the installer to ensure that the equipment is installed correctly with regard to all instructions given in this guide. They must give due consideration to the safety of the complete system, so as to avoid the risk of injury both in normal operation and in the event of a fault or of reasonably foreseeable misuse.

The manufacturer accepts no liability for any consequences resulting from inappropriate, negligent or incorrect installation of the equipment.

1.4 Compliance with regulations

The installer is responsible for complying with all relevant regulations, such as national wiring regulations, accident prevention regulations and electromagnetic compatibility (EMC) regulations. Particular attention must be given to the cross-sectional areas of conductors, the selection of fuses or other protection, and protective ground (earth) connections.

This guide contains instructions for achieving compliance with specific EMC standards.

All machinery to be supplied within the European Union in which this product is used must comply with the following directives:

2006/42/EC Safety of machinery.

2014/30/EU: Electromagnetic Compatibility.

1.5 Electrical hazards

The voltages used in the drive can cause severe electrical shock and/or burns, and could be lethal. Extreme care is necessary at all times when working with or adjacent to the drive. Hazardous voltage may be present in any of the following locations:

- AC and DC supply cables and connections
- Output cables and connections
- Many internal parts of the drive, and external option units

Unless otherwise indicated, control terminals are single insulated and must not be touched.

The supply must be disconnected by an approved electrical isolation device before gaining access to the electrical connections.

The STOP and Safe Torque Off functions of the drive do not isolate dangerous voltages from the output of the drive or from any external option unit.

The drive must be installed in accordance with the instructions given in this guide. Failure to observe the instructions could result in a fire hazard.

1.6 Stored electrical charge

The drive contains capacitors that remain charged to a potentially lethal voltage after the AC supply has been disconnected. If the drive has been energized, the AC supply must be isolated at least ten minutes before work may continue.

1.7 Mechanical hazards

Careful consideration must be given to the functions of the drive or controller which might result in a hazard, either through their intended behaviour or through incorrect operation due to a fault. In any application where a malfunction of the drive or its control system could lead to or allow damage, loss or injury, a risk analysis must be carried out, and where necessary, further measures taken to reduce the risk - for example, an over-speed protection device in case of failure of the speed control, or a fail-safe mechanical brake in case of loss of motor braking.

With the sole exception of the Safe Torque Off function, none of the drive functions must be used to ensure safety of personnel, i.e. they must not be used for safety-related functions.

The Safe Torque Off function may be used in a safety-related application. The system designer is responsible for ensuring that the complete system is safe and designed correctly according to the relevant safety standards.

The design of safety-related control systems must only be done by personnel with the required training and experience. The Safe Torque Off function will only ensure the safety of a machine if it is correctly incorporated into a complete safety system. The system must be subject to a risk assessment to confirm that the residual risk of an unsafe event is at an acceptable level for the application.

1.8 Access to equipment

Access must be restricted to authorized personnel only. Safety regulations which apply at the place of use must be complied with.

1.9 Environmental limits

Instructions in this guide regarding transport, storage, installation and use of the equipment must be complied with, including the specified environmental limits. This includes temperature, humidity, contamination, shock and vibration. Drives must not be subjected to excessive physical force.

1.10 Hazardous environments

The equipment must not be installed in a hazardous environment (i.e. a potentially explosive environment).

1.11 Motor

The safety of the motor under variable speed conditions must be ensured.

To avoid the risk of physical injury, do not exceed the maximum specified speed of the motor.

Low speeds may cause the motor to overheat because the cooling fan becomes less effective, causing a fire hazard. The motor should be installed with a protection thermistor. If necessary, an electric forced vent fan should be used.

The values of the motor parameters set in the drive affect the protection of the motor. The default values in the drive must not be relied upon. It is essential that the correct value is entered in the Motor Rated Current parameter.

1.12 Mechanical brake control

Any brake control functions are provided to allow well co-ordinated operation of an external brake with the drive. While both hardware and software are designed to high standards of quality and robustness, they are not intended for use as safety functions, i.e. where a fault or failure would result in a risk of injury. In any application where the incorrect operation of the brake release mechanism could result in injury, independent protection devices of proven integrity must also be incorporated.

1.13 Adjusting parameters

Some parameters have a profound effect on the operation of the drive. They must not be altered without careful consideration of the impact on the controlled system. Measures must be taken to prevent unwanted changes due to error or tampering.

1.14 Electromagnetic compatibility (EMC)

Installation instructions for a range of EMC environments are provided in the relevant Power Installation Guide. If the installation is poorly designed or other equipment does not comply with suitable standards for EMC, the product might cause or suffer from disturbance due to electromagnetic interaction with other equipment. It is the responsibility of the installer to ensure that the equipment or system into which the product is incorporated complies with the relevant EMC legislation in the place of use.

2 Product information

2.1 Introduction

This guide provides the information necessary to install the following drive models:

Unidrive M600 to M702 frame 3 to 4

Unidrive HS70 to HS72 frame 3 to 4

This guide focuses on the drive power section, for example: electrical installation of the supply / motor cables and mechanical installation of the drive.

For information about the drive control section, for example: parameter set up information, control and encoder connections please refer to the *Control User Guide*.

2.2 Model number

The model numbers for the *Unidrive M/HS* product range are formed as illustrated below:

Figure 2-1 Model number

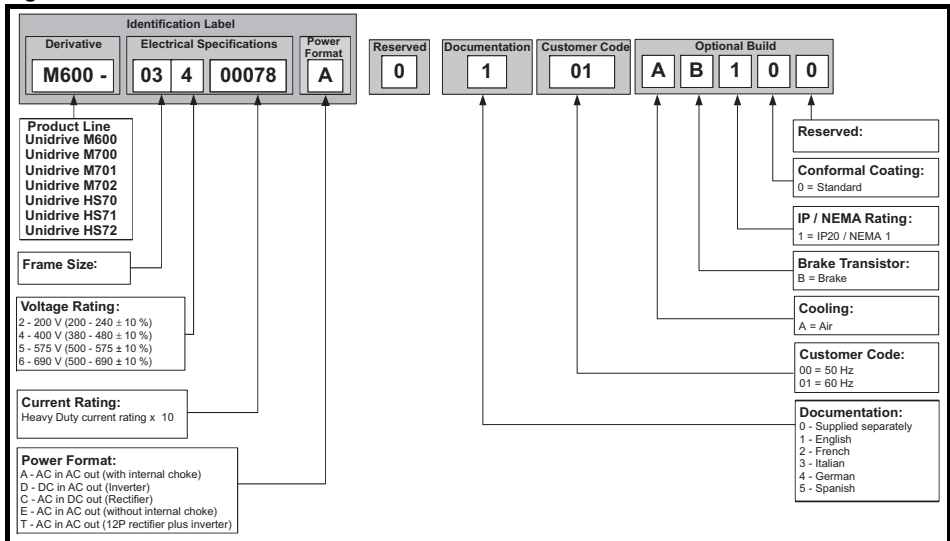

2.3 Nameplate description

Figure 2-2 Typical drive rating labels

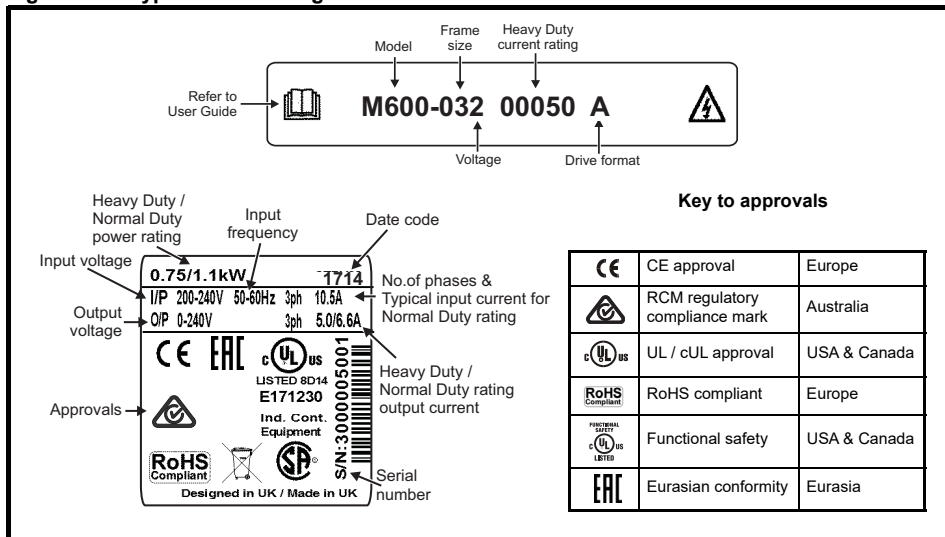

NOTE Date code format

The date code is four numbers. The first two numbers indicate the year and the remaining numbers indicate the week of the year in which the drive was built.

Example:

A date code of **1710** would correspond to week 10 of year 2017.

2.4 Ratings



Fuses

The AC supply to the drive must be installed with suitable protection against overload and short-circuits. The following section shows recommended fuse ratings. Failure to observe this requirement will cause risk of fire.

NOTE Nominal cables sizes below are based on the cable installation method B2 (ref: IEC60364-5-52:2001) unless otherwise specified, and are provided as a guide only. Ensure cables used suit local wiring regulations.

The continuous output current ratings given below are for maximum 40 °C (104 °F), 1000 m altitude and 3 kHz switching frequency. Derating is required for higher switching frequencies, ambient temperature >40 °C (104 °F) and high altitude. For further information, refer to Chapter 5 *Technical data* on page 77.

Table 2-1 200 V drive ratings, cable sizes and fuse ratings

Model	Max. cont. input current	Fuse					Nominal cable size				Normal Duty			Heavy Duty		
		IEC			UL		European		USA		Max. cont. output current	Nom power @ 230 V	Motor power @ 230 V	Max. cont. output current	Nom power @ 230 V	Motor power @ 230 V
		3ph	Nom	Class	Nom	Class	Input	Output	Input	Output						
03200050	10.7	16	gG	16	CC, J or T*	1.5	1.5	14	14	6.6	1.1	1.5	5	0.75	1	
03200066	13	20		20		1.5	1.5	14	14	8	1.5	2	6.6	1.1	1.5	
03200080	17.8	25		25		4	4	12	12	11	2.2	3	8	1.5	2	
03200106	20.6	25		25		4	4	12	12	12.7	3	3	10.6	2.2	3	
04200137	20.1	25	gG	25	CC, J or T*	6	6	10	10	18	4	5	13.7	3	3	
04200185	26.8	32		30		8	8	8	8	25	5.5	7.5	18.5	4	5	

Table 2-2 400 V drive ratings, cable sizes and fuse ratings

Model	Max. cont. input current	Fuse					Nominal cable size				Normal Duty			Heavy Duty		
		IEC			UL		European		USA		Max. cont. output current	Nom power @ 400 V	Motor power @ 460 V	Max. cont. output current	Nom power @ 400 V	Motor power @ 460 V
		3ph	Nom	Class	Nom	Class	Input	Output	Input	Output						
03400025	5	6	gG	10	CC, J or T*	1.5	1.5	18	18	3.4	1.1	1.5	2.5	0.75	1.0	
03400031	6.6	10		10		1.5	1.5	16	16	4.5	1.5	2	3.1	1.1	1.5	
03400045	9.1	10		10		1.5	1.5	14	14	6.2	2.2	3	4.5	1.5	2.0	
03400062	13.1	20		20		2.5	2.5	14	14	7.7	3	5	6.2	2.2	3.0	
03400078	13.4	20		20		2.5	2.5	14	14	10.4	4	5	7.8	3	5.0	
03400100	15.8	20		20		2.5	2.5	12	12	12.3	5.5	7.5	10	4	5.0	
04400150	18.7	25	gG	25	CC, J or T*	4	4	10	10	18.5	7.5	10	15	5.5	10.0	
04400172	24.3	32		30		6	6	8	8	24	11	15	17.2	7.5	10.0	

* These fuses are fast acting.

NOTE Refer to Chapter 5 *Technical data* on page 77 for maximum fuse rating, maximum cable size and peak currents.

Table 2-3 Protective ground cable ratings

Input phase conductor size	Minimum ground conductor size
$\leq 10 \text{ mm}^2$	Either 10 mm^2 or two conductors of the same cross-sectional area as the input phase conductor
$> 10 \text{ mm}^2$ and $\leq 16 \text{ mm}^2$	The same cross-sectional area as the input phase conductor
$> 16 \text{ mm}^2$ and $\leq 35 \text{ mm}^2$	16 mm^2
$> 35 \text{ mm}^2$	Half of the cross-sectional area of the input phase conductor

Typical short term overload limits

The maximum percentage overload limit changes depending on the selected motor. Variations in motor rated current, motor power factor and motor leakage inductance all result in changes in the maximum possible overload. Typical values are shown in the table below:

Table 2-4 Typical overload limits

Operating mode	RFC from cold	RFC from 100 %	Open loop from cold	Open loop from 100 %
Normal Duty overload with motor rated current = drive rated current	110 % for 165 s	110 % for 9 s	110 % for 165 s	110 % for 9 s
Heavy Duty overload with motor rated current = drive rated current	200 % for 28 s	200 % for 3 s	150 % for 60 s	150 % for 7 s

Generally the drive rated current is higher than the matching motor rated current allowing a higher level of overload than the default setting.

The time allowed in the overload region is proportionally reduced at very low output frequency on some drive ratings.

NOTE The maximum overload level which can be attained is independent of the speed.

Output current

The continuous output current ratings given on the rating label are for maximum $40 \text{ }^\circ\text{C}$ ($104 \text{ }^\circ\text{F}$), 1000 m altitude and 3 kHz switching frequency. Derating is required for higher switching frequencies, ambient temperatures $>40 \text{ }^\circ\text{C}$ ($104 \text{ }^\circ\text{F}$) and higher altitude. For derating information, refer to the Chapter 5 *Technical data* on page 77.

Input current

The input current is affected by the supply voltage and impedance. The input current given on the rating label is the typical input current and is stated for a balanced supply.

2.5 Drive features

Figure 2-3 Features of the drive power section

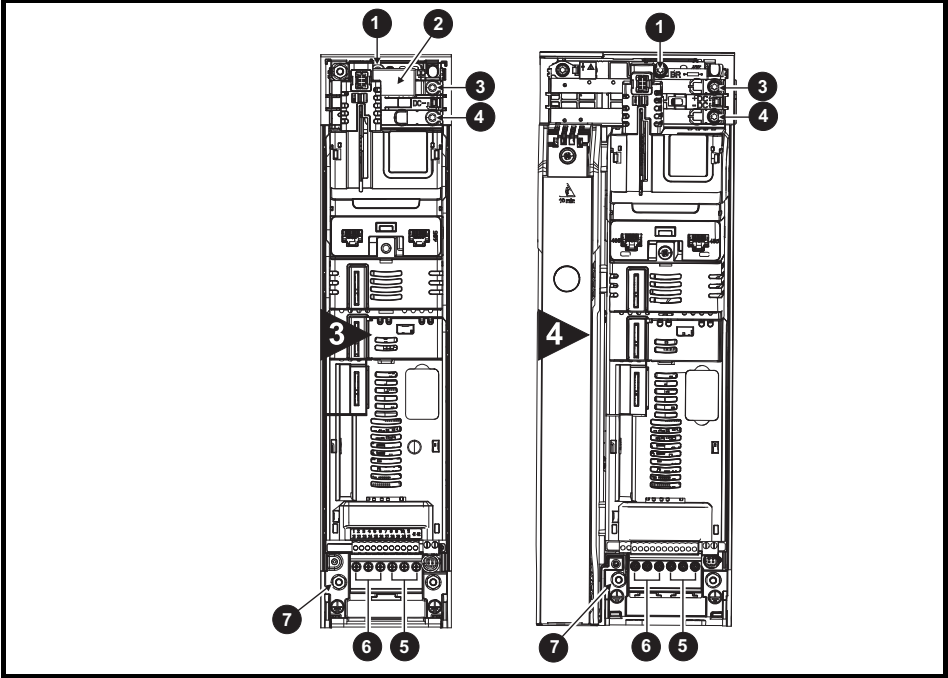







Key

- | | | | |
|----------------------|--------------------------|-----------------------|-------------|
| 1. Braking terminal | 2. Internal EMC filter | 3. DC bus + | 4. DC bus - |
| 5. Motor connections | 6. AC supply connections | 7. Ground connections | |

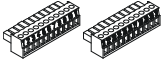
2.6 Items supplied with the drive

The drive is supplied with a copy of the *Power Installation Guide* and a copy of the *Control Getting Started Guide*, a safety information booklet, the Certificate of Quality and an accessory kit box including the items shown in Table 2-5.

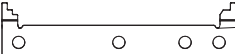
Table 2-5 Parts supplied with the drive

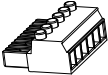
Description	Size 3	Size 4
Control connectors (1 to 11 way and 21 to 31 way)	 x 1* x 1*	
Control connectors (1 to 13)	 x 1**	
Relay connector	 x 1	
Grounding bracket	 x 1	
Surface mounting brackets	 x 2	 x 2
Grounding clamp	 x 1	
DC terminal cover grommets	 x 2	
Supply and motor connector	 x 1	

* Supplied with Unidrive M600 / M700 / M701 and HS70 / 71 only.

** Supplied with Unidrive M702 and HS72 only.

3 Mechanical installation

3.1 Safety information



Follow the instructions

The mechanical and electrical installation instructions must be adhered to. Any questions or doubt should be referred to the supplier of the equipment. It is the responsibility of the owner or user to ensure that the installation of the drive and any external option unit, and the way in which they are operated and maintained, comply with the requirements of the Health and Safety at Work Act in the United Kingdom or applicable legislation and regulations and codes of practice in the country in which the equipment is used.



Stored charge

The drive contains capacitors that remain charged to a potentially lethal voltage after the AC supply has been disconnected. If the drive has been energized, the AC supply must be isolated at least ten minutes before work may continue.

Normally, the capacitors are discharged by an internal resistor. Under certain, unusual fault conditions, it is possible that the capacitors may fail to discharge, or be prevented from being discharged by a voltage applied to the output terminals. If the drive has failed in a manner that causes the display to go blank immediately, it is possible the capacitors will not be discharged. In this case, consult Nidec Industrial Automation or their authorized distributor.



Competence of the installer

The drive must be installed by professional assemblers who are familiar with the requirements for safety and EMC. The assembler is responsible for ensuring that the end product or system complies with all the relevant laws in the country where it is to be used.



Enclosure

The drive is intended to be mounted in an enclosure which prevents access except by trained and authorized personnel, and which prevents the ingress of contamination. It is designed for use in an environment classified as pollution degree 2 in accordance with IEC 60664-1. This means that only dry, non-conducting contamination is acceptable.

3.2 Planning the installation

The following considerations must be made when planning the installation:

3.2.1 Access

Access must be restricted to authorized personnel only. Safety regulations which apply at the place of use must be complied with.

The IP (Ingress Protection) rating of the drive is installation dependent. For further information, refer to section 3.8 *Enclosing standard drive for high environmental protection* on page 33.

3.2.2 Environmental protection

The drive must be protected from:

- Moisture, including dripping water or spraying water and condensation. An anti-condensation heater may be required, which must be switched off when the drive is running.
- Contamination with electrically conductive material
- Contamination with any form of dust which may restrict the fan, or impair airflow over various components
- Temperature beyond the specified operating and storage ranges
- Corrosive gasses

NOTE During installation it is recommended that the vents on the drive are covered to prevent debris (e.g. wire off-cuts) from entering the drive.

3.2.3 Cooling

The heat produced by the drive must be removed without its specified operating temperature being exceeded. Note that a sealed enclosure gives much reduced cooling compared with a ventilated one, and may need to be larger and/or use internal air circulating fans.

For further information, refer to section 3.5 *Enclosure for standard drives* on page 28.

3.2.4 Electrical safety

The installation must be safe under normal and fault conditions. Electrical installation instructions are given in Chapter 4 *Electrical installation* on page 46.

3.2.5 Fire protection

The drive enclosure is not classified as a fire enclosure. A separate fire enclosure must be provided. For installation in the USA, a NEMA 12 enclosure is suitable.

For installation outside the USA, the following (based on IEC 62109-1, standard for PV inverters) is recommended.

Enclosure can be metal and/or polymeric, polymer must meet requirements which can be summarized for larger enclosures as using materials meeting at least UL 94 class 5VB at the point of minimum thickness.

Air filter assemblies to be at least class V-2.

The location and size of the bottom shall cover the area shown in Figure 3-1. Any part of the side which is within the area traced out by the 5° angle is also considered to be part of the bottom of the fire enclosure.

Figure 3-1 Fire enclosure bottom layout

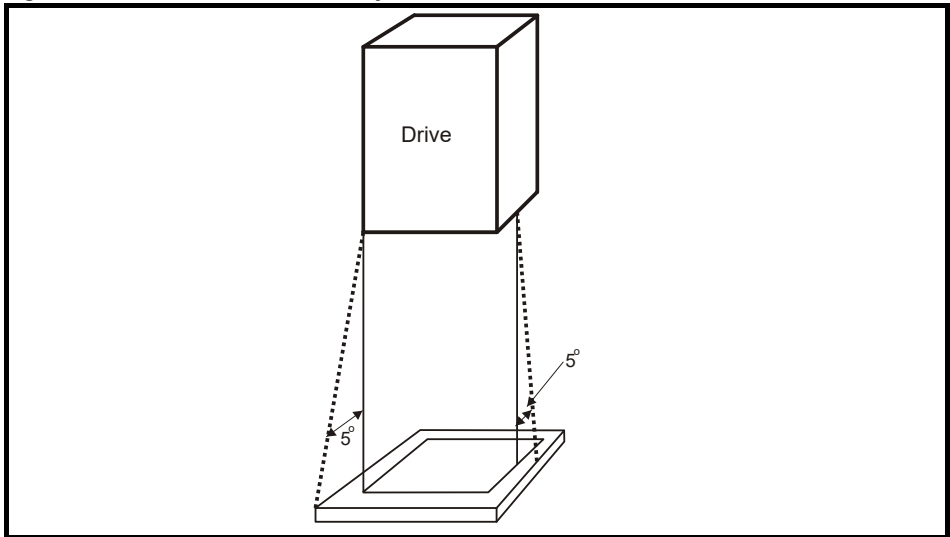

The bottom, including the part of the side considered to be part of the bottom, must be designed to prevent escape of burning material - either by having no openings or by having a baffle construction. This means that openings for cables etc. must be sealed with materials meeting the 5VB requirement, or else have a baffle above. See Figure 3-2 for acceptable baffle construction. This does not apply for mounting in an enclosed electrical operating area (restricted access) with concrete floor.

Figure 3-2 Fire enclosure baffle construction

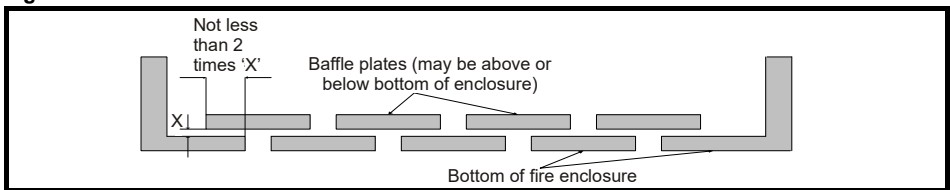

3.2.6 Electromagnetic compatibility

Variable speed drives are powerful electronic circuits which can cause electromagnetic interference if not installed correctly with careful attention to the layout of the wiring.

Some simple routine precautions can prevent disturbance to typical industrial control equipment.

If it is necessary to meet strict emission limits, or if it is known that electromagnetically sensitive equipment is located nearby, then full precautions must be observed. In-built into the drive, is an internal EMC filter, which reduces emissions under certain conditions. If these conditions are exceeded, then the use of an external EMC filter may be required at the drive inputs, which must be located very close to the drives. Space must be made available for the filters and allowance made for carefully segregated wiring. Both levels of precautions are covered in section 4.12 *EMC (Electromagnetic compatibility) on page 64.*

3.2.7 Hazardous areas

The drive must not be located in a classified hazardous area unless it is installed in an approved enclosure and the installation is certified.

3.3 Terminal cover removal



Isolation device

The AC and / or DC power supply must be disconnected from the drive using an approved isolation device before any cover is removed from the drive or before any servicing work is performed.



Stored charge

The drive contains capacitors that remain charged to a potentially lethal voltage after the AC and / or DC power supply has been disconnected. If the drive has been energized, the power supply must be isolated at least ten minutes before work may continue.

Normally, the capacitors are discharged by an internal resistor. Under certain, unusual fault conditions, it is possible that the capacitors may fail to discharge, or be prevented from being discharged by a voltage applied to the output terminals. If the drive has failed in a manner that causes the display to go blank immediately, it is possible the capacitors will not be discharged. In this case, consult Nidec Industrial Automation or their authorized distributor.

3.3.1 Removing the terminal covers

Figure 3-3 Location and identification of terminal covers (size 3 to 4)

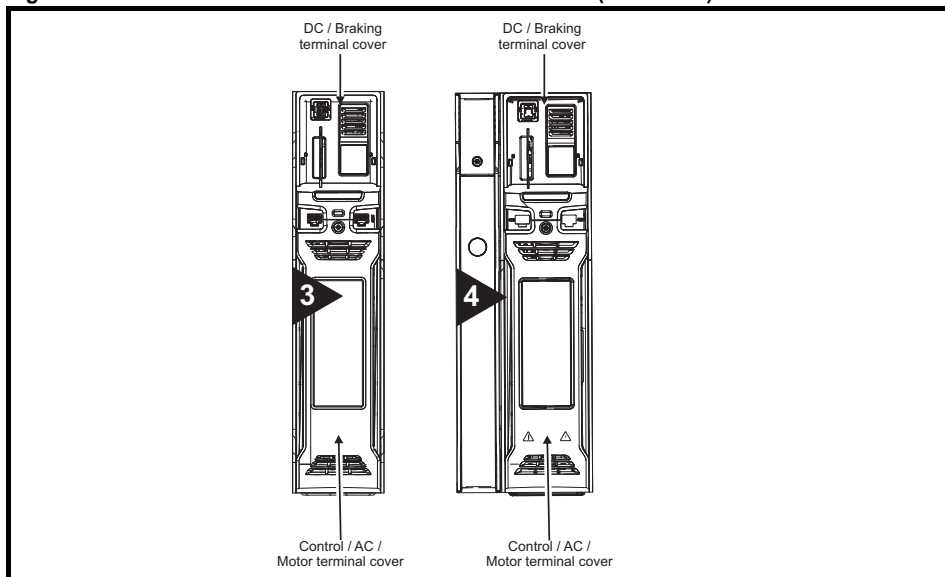
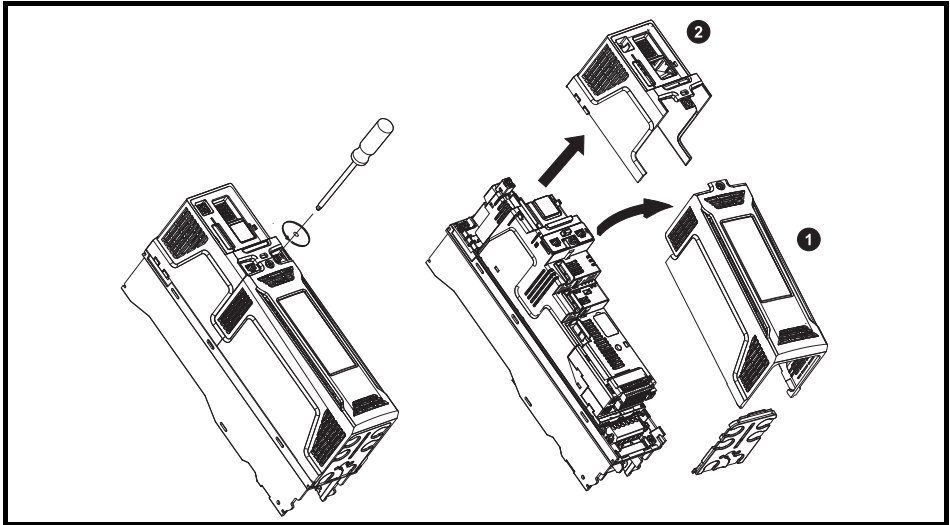

Figure 3-4 Removing the size 3 terminal covers



1. Control / AC / Motor terminal cover

2. DC / Braking terminal cover

The Control / AC / Motor terminal cover must be removed before removal of the DC / Braking terminal cover. When replacing the terminal covers, the screws should be tightened to a maximum torque of 1 N m (0.7 lb ft).

Figure 3-5 Removing the size 4 terminal covers

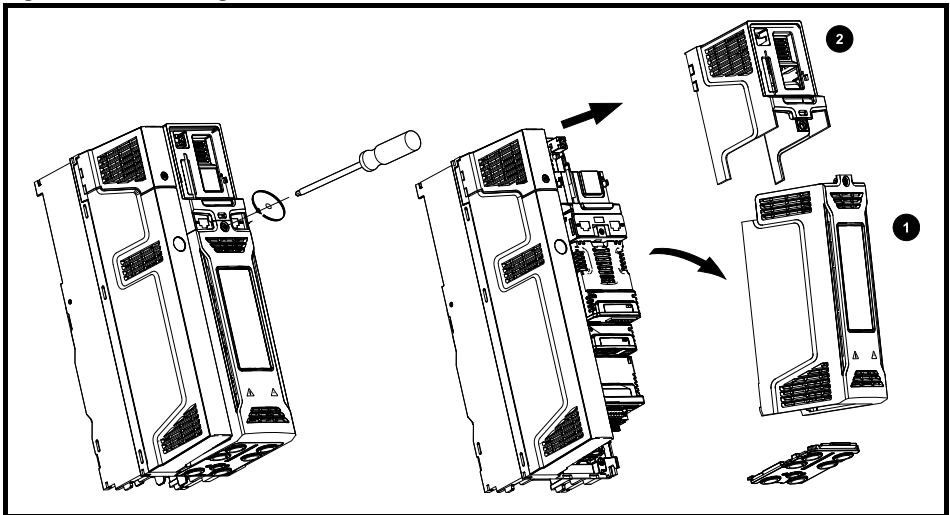

1. Control / AC / Motor terminal cover

2. DC / Braking terminal cover

The Control / AC / Motor terminal cover must be removed before removal of the DC / Braking terminal cover. When replacing the terminal covers, the screws should be tightened to a maximum torque of 1 N m (0.7 lb ft).

3.3.2 Removing the finger-guard and DC terminal cover break-outs

Figure 3-6 Removing the finger-guard break-outs

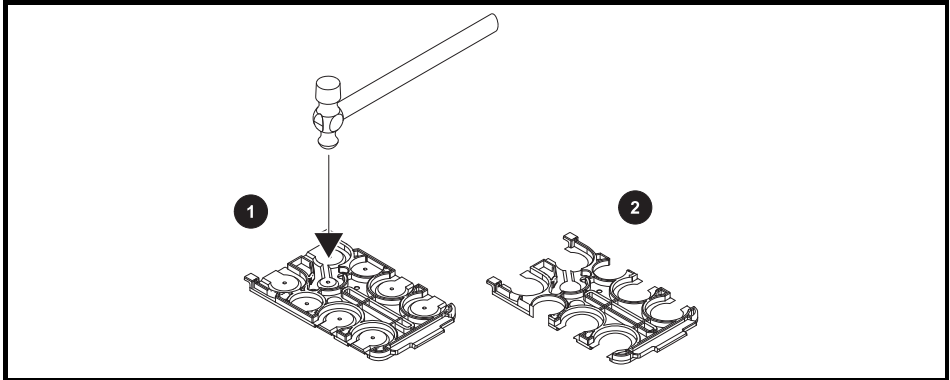

Place finger-guard on a flat solid surface and hit relevant break-outs with hammer as shown (1). Continue until all required break-outs are removed (2). Remove any flash / sharp edges once the break-outs are removed.

Figure 3-7 Removing the size 3 and 4 DC terminal cover break-outs

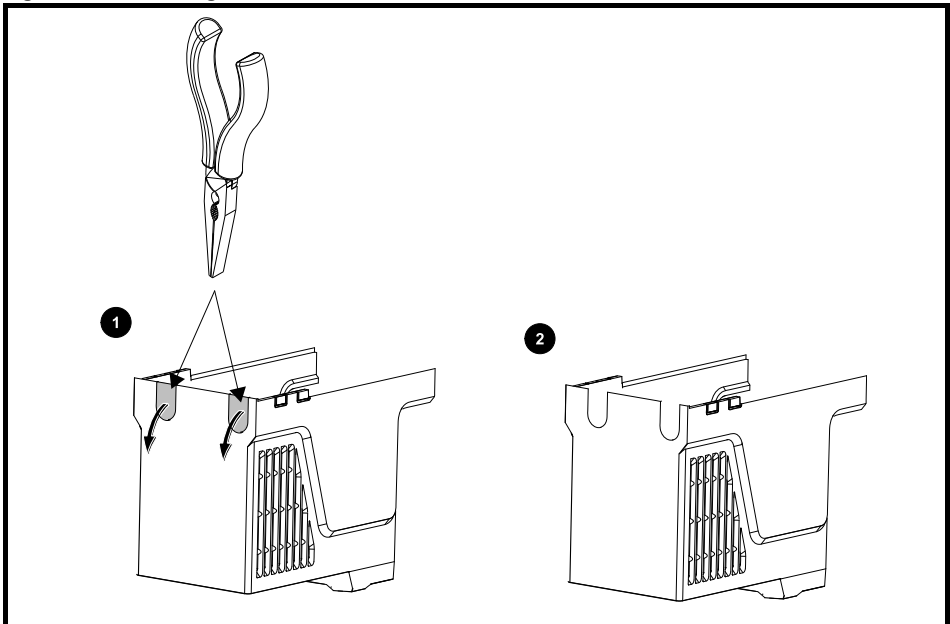

Grasp the DC terminal cover break-outs with pliers as shown (1) and pull down in the direction shown to remove. Continue until all required break-outs are removed (2). Remove any flash / sharp edges once the break-outs are removed. Use the DC terminal cover grommets supplied in the accessory box (Table 2-5 *Parts supplied with the drive* on page 17) to maintain the seal at the top of the drive.

3.4 Dimensions and mounting methods

Drive sizes 3 and 4 can be surface, through-panel or tile mounted using the appropriate brackets.



If the drive has been used at high load levels for a period of time, the heatsink can reach temperatures in excess of 70 °C (158 °F). Human contact with the heatsink should be prevented.

3.4.1 Drive dimensions

Figure 3-8 Drive dimensions (size 3 illustrated)

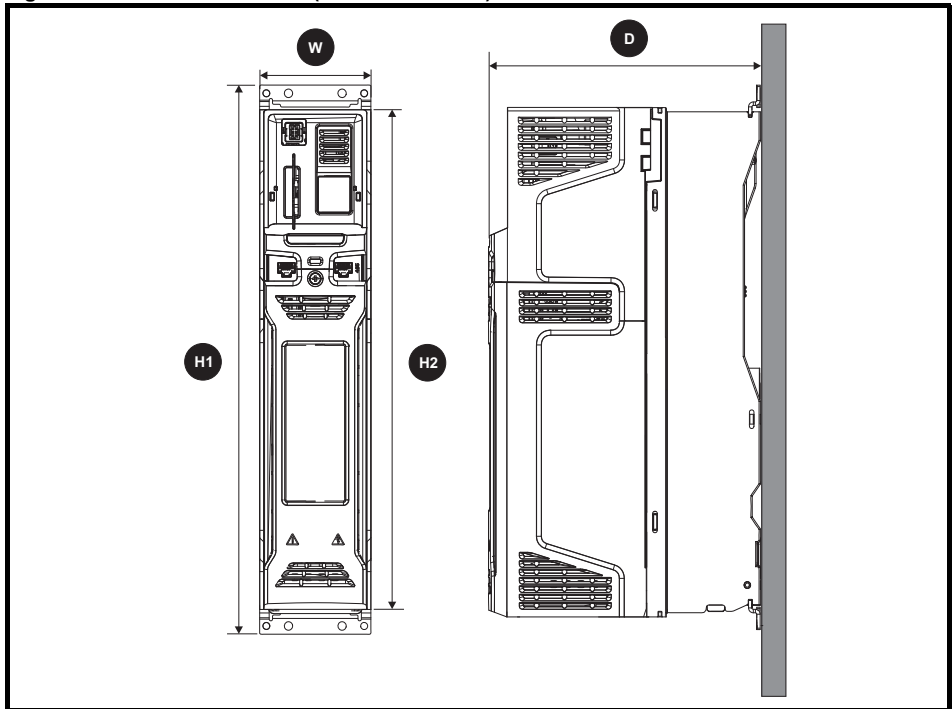

Size	H1		H2		W		D	
	mm	in	mm	in	mm	in	mm	in
3	382	15.04	365	14.37	83	3.27	200	7.87
4	391	15.39			124	4.88		

3.4.2 Surface mounting

Figure 3-9 Surface mounting dimensions

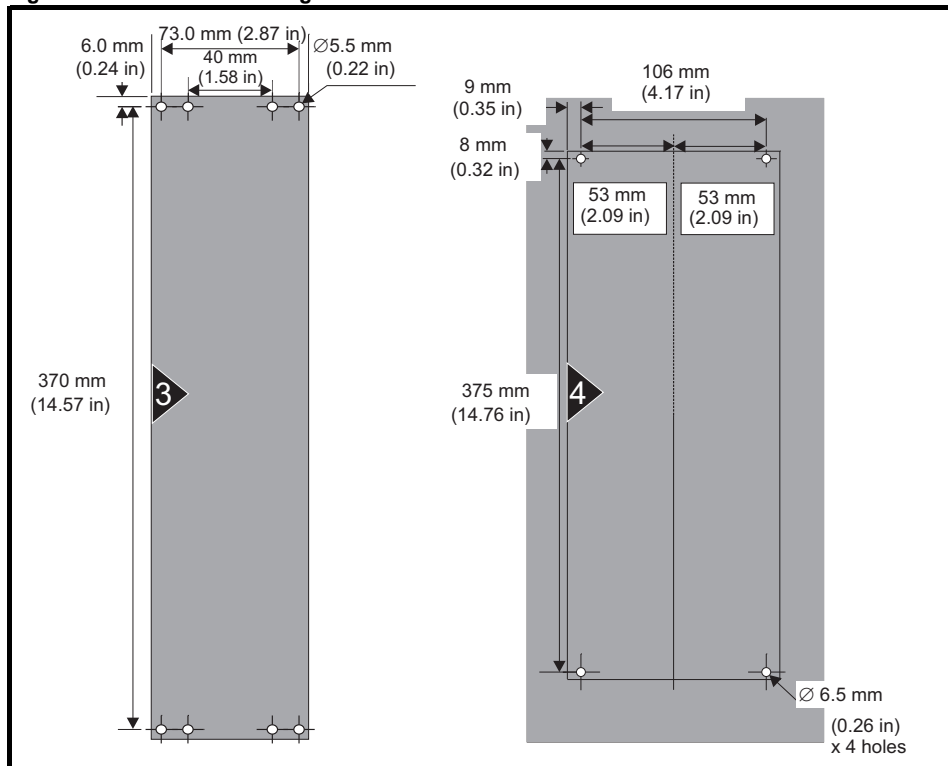

Surface mounting size 3

Each mounting bracket contains 5 mounting slots / holes, the outer holes (5.2 mm) x 2 should be used for mounting the drive to the backplate as this allows the heatsink fan to be replaced without removing the drive from the backplate. The inner slots / holes (6.2 mm) x 3 are used for Unidrive SP size 1 retrofit applications.

Surface mounting size 4

The outer holes in the mounting bracket (6.5 mm) x 2 are to be used for surface mounting.

3.4.3 Through-panel mounting

The drive can be through-panel mounted using the appropriate brackets, see section 3.8 *Enclosing standard drive for high environmental protection* on page 33 for further details.

The through-panel mounting kit is not supplied with the drive and can be purchased separately, below are the relevant part numbers:

Size	CT part number
3	3470-0053
4	3470-0056





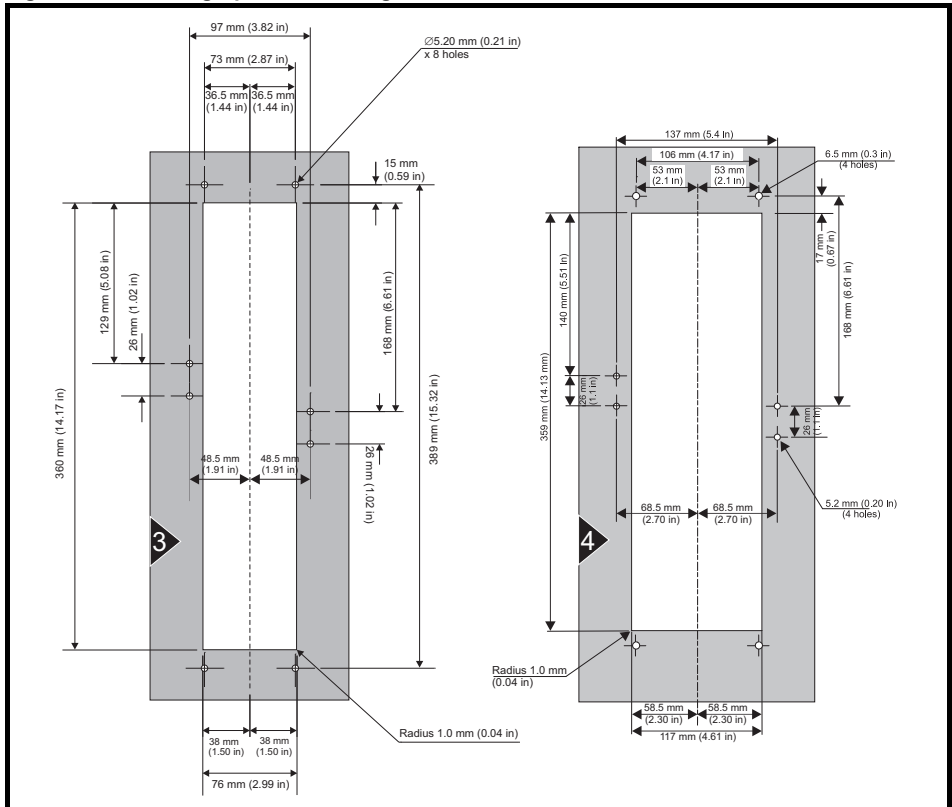

If the drive has been used at high load levels for a period of time, the heatsink can reach temperatures in excess of 70 °C (158 °F). Human contact with the heatsink should be prevented.

Figure 3-10 Through-panel mounting dimensions

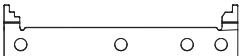

3.4.4 Mounting brackets

Table 3-1 Mounting brackets

Frame size	Surface	Qty	Through-panel*	Qty
3	 <p>Outer hole size: 5.2 mm (0.20 in) Centre hole / slot size: 6.2 mm (0.24 in)</p>	x 2	 <p>Hole size: 5.2 mm (0.21 in)</p>	x 2
				x 1
4	 <p>Hole size: 6.5 mm (0.26 in)</p>	x 2	 <p>Hole size: 5.2 mm (0.21 in)</p>	x 2
				x 1

* A gasket is supplied in the through-panel mounting kit, see section 3.8 *Enclosing standard drive for high environmental protection* on page 33 for further details.

NOTE

A retrofit kit is available for Unidrive M/HS size 4 that allows mounting of the drive in applications previously using Unidrive SP size 2, the part number of this kit is 3470-0062. A similar kit is not necessary for Unidrive M/HS size 3 because it has the same mounting hole positions as Unidrive SP size 1.

3.4.5 Tile mounting

Drive sizes 3 to 4 can be tile mounted where limited mounting space is available. The drive is mounted sideways with the side panel against the mounting surface as shown in Figure 3-11. The tile mounting kit is not supplied with the drive, it can be purchased separately using the following part numbers:

Size	CT part number
3	3470-0049
4	3470-0060

Figure 3-11 Tile mounting

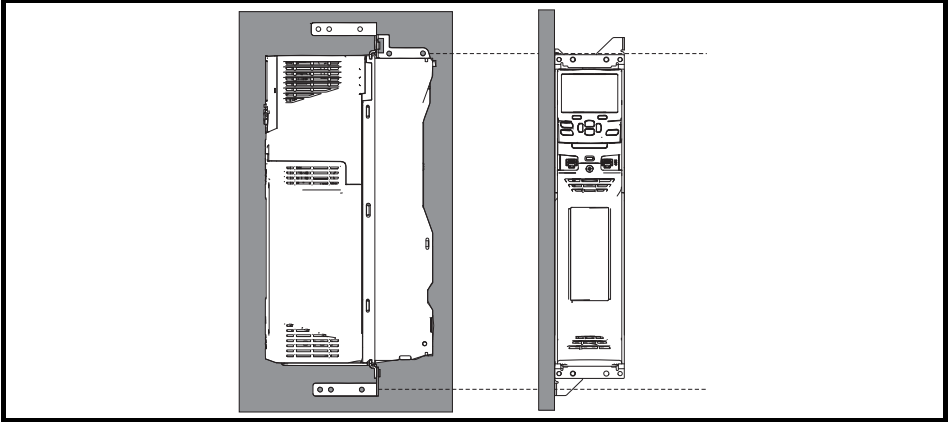

3.5 Enclosure for standard drives

Figure 3-12 Recommended spacing between the drives

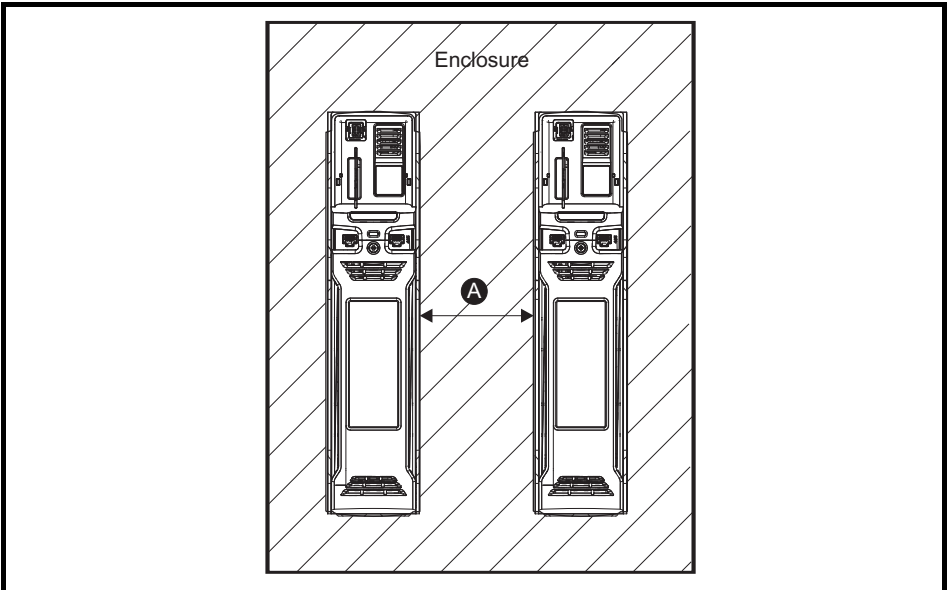

Table 3-2 Spacing required between the drives (without high IP insert)

Drive Size	Spacing (A)	
	40°C	50°C*
3	0 mm (0.00 in)	
4		

* 50 °C derating applies, refer to Table 5-5 *Maximum permissible continuous output current @ 50 °C (122 °F)* on page 80.

NOTE When through-panel mounted, ideally drives should be spaced 30 mm (1.18 in) to maximize panel stiffness.

3.5.1 Enclosure layout

Please observe the clearances in the diagram below taking into account any appropriate notes for other devices / auxiliary equipment when planning the installation.

Figure 3-13 Enclosure layout

Table 3-3 Spacing required between drive / enclosure and drive / EMC filter

Drive Size	Spacing (B)
3	0 mm (0.00 in)
4	30 mm (1.18 in)

NOTE For EMC compliance:

1. When using an external EMC filter, one filter is required for each drive.
2. Power cabling must be at least 100 mm (4 in) from the drive in all directions

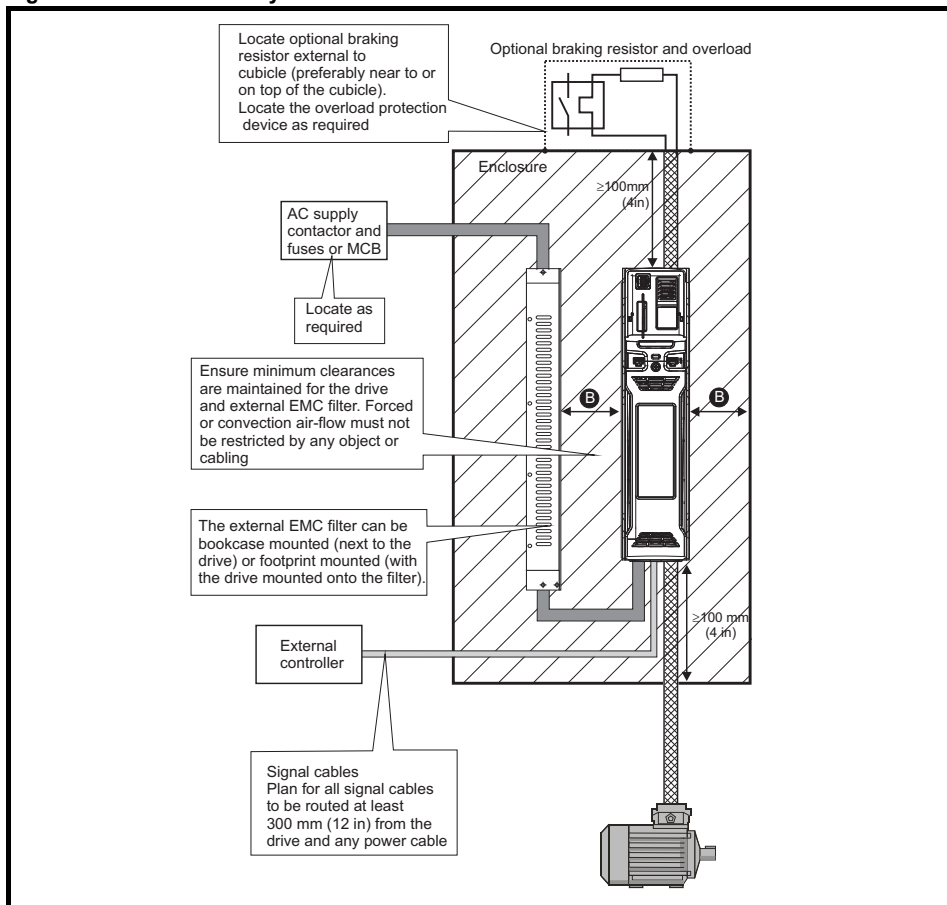
3.5.2 Enclosure sizing

1. Add the dissipation figures from section 5.1.3 *Power dissipation* on page 81 for each drive that is to be installed in the enclosure.
2. If an external EMC filter is to be used with each drive, add the dissipation figures from section 5.2.1 *EMC filter ratings* on page 97 for each external EMC filter that is to be installed in the enclosure.
3. If the braking resistor is to be mounted inside the enclosure, add the average power figures from for each braking resistor that is to be installed in the enclosure.
4. Calculate the total heat dissipation (in Watts) of any other equipment to be installed in the enclosure.
5. Add the heat dissipation figures obtained above. This gives a figure in Watts for the total heat that will be dissipated inside the enclosure.

Calculating the size of a sealed enclosure

The enclosure transfers internally generated heat into the surrounding air by natural convection (or external forced air flow); the greater the surface area of the enclosure walls, the better is the dissipation capability. Only the surfaces of the enclosure that are unobstructed (not in contact with a wall or floor) can dissipate heat.

Calculate the minimum required unobstructed surface area A_e for the enclosure from:

$$A_e = \frac{P}{k(T_{int} - T_{ext})}$$

Where:

- A_e Unobstructed surface area in m^2 ($1 m^2 = 10.9 ft^2$)
- T_{ext} Maximum expected temperature in $^{\circ}C$ *outside* the enclosure
- T_{int} Maximum permissible temperature in $^{\circ}C$ *inside* the enclosure
- P Power in Watts dissipated by *all* heat sources in the enclosure
- k Heat transmission coefficient of the enclosure material in $W/m^2/^{\circ}C$

Example

To calculate the size of an enclosure for the following:

- Two drives operating at the Normal Duty rating
- External EMC filter for each drive
- Braking resistors are to be mounted outside the enclosure
- Maximum ambient temperature inside the enclosure: $40^{\circ}C$
- Maximum ambient temperature outside the enclosure: $30^{\circ}C$

For example, if the power dissipation from each drive is 187 W and the power dissipation from each external EMC filter is 9.2 W.

Total dissipation: $2 \times (187 + 9.2) = 392.4 W$

NOTE

Power dissipation for the drives and the external EMC filters can be obtained from Chapter 5 *Technical data* on page 77.

The enclosure is to be made from painted 2 mm (0.079 in) sheet steel having a heat transmission coefficient of 5.5 W/m²/°C. Only the top, front, and two sides of the enclosure are free to dissipate heat.

The value of 5.5 W/m²/°C can generally be used with a sheet steel enclosure (exact values can be obtained by the supplier of the material). If in any doubt, allow for a greater margin in the temperature rise.

Figure 3-14 Enclosure having front, sides and top panels free to dissipate heat

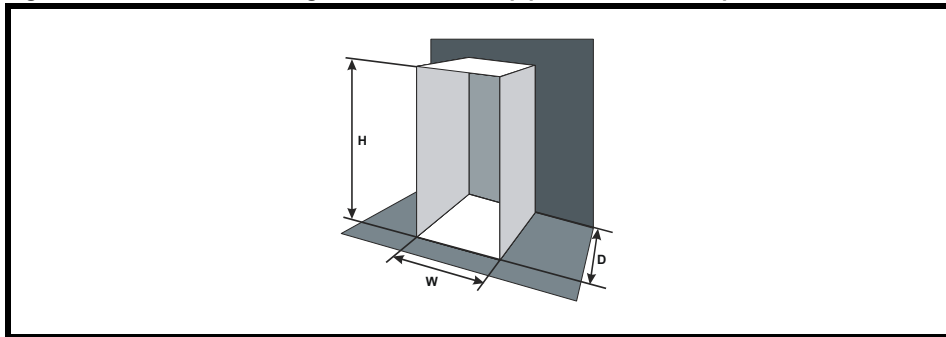

Insert the following values:

T_{int}	40 °C
T_{ext}	30 °C
k	5.5
P	392.4 W

The minimum required heat conducting area is then:

$$A_e = \frac{392.4}{5.5(40 - 30)}$$

$$= 7.135 \text{ m}^2 (77.8 \text{ ft}^2) \quad (1 \text{ m}^2 = 10.9 \text{ ft}^2)$$

Estimate two of the enclosure dimensions - the height (H) and depth (D), for instance. Calculate the width (W) from:

$$W = \frac{A_e - 2HD}{H + D}$$

Inserting $H = 2\text{m}$ and $D = 0.6\text{ m}$, obtain the minimum width:

$$W = \frac{7.135 - (2 \times 2 \times 0.6)}{2 + 0.6}$$

$$= 1.821 \text{ m (71.7 in)}$$

If the enclosure is too large for the space available, it can be made smaller only by attending to one or all of the following:

- Using a lower PWM switching frequency to reduce the dissipation in the drives
- Reducing the ambient temperature outside the enclosure, and/or applying forced-air cooling to the outside of the enclosure
- Reducing the number of drives in the enclosure
- Removing other heat-generating equipment

Calculating the air-flow in a ventilated enclosure

The dimensions of the enclosure are required only for accommodating the equipment. The equipment is cooled by the forced air flow.

Calculate the minimum required volume of ventilating air from:

$$V = \frac{3kP}{T_{\text{int}} - T_{\text{ext}}}$$

Where:

V	Air-flow in m ³ per hour (1 m ³ /hr = 0.59 ft ³ /min)
T_{ext}	Maximum expected temperature in °C <i>outside</i> the enclosure
T_{int}	Maximum permissible temperature in °C <i>inside</i> the enclosure
P	Power in Watts dissipated by <i>all</i> heat sources in the enclosure
k	Ratio of $\frac{P_o}{P_i}$

Where:

P₀	is the air pressure at sea level
P₁	is the air pressure at the installation

Typically use a factor of 1.2 to 1.3, to allow also for pressure-drops in dirty air-filters.

Example

To calculate the size of an enclosure for the following:

- Three drives operating at the Normal Duty rating
- External EMC filter for each drive
- Braking resistors are to be mounted outside the enclosure
- Maximum ambient temperature inside the enclosure: 40 °C
- Maximum ambient temperature outside the enclosure: 30 °C

For example, dissipation of each drive: 101 W and dissipation of each external EMC filter: 6.9 W (max).

Total dissipation: 3 x (101 + 6.9) = 323.7 W

Insert the following values:

T_{int}	40 °C
T_{ext}	30 °C
k	1.3
P	323.7 W

Then:

$$V = \frac{3 \times 1.3 \times 323.7}{40 - 30}$$

$$= 126.2 \text{ m}^3/\text{hr} \text{ (74.5 ft}^3/\text{min)} \quad (1 \text{ m}^3/\text{hr} = 0.59 \text{ ft}^3/\text{min)}$$

3.6 Enclosure design and drive ambient temperature

Drive derating is required for operation in high ambient temperatures

Totally enclosing or through panel mounting the drive in either a sealed cabinet (no airflow) or in a well ventilated cabinet makes a significant difference on drive cooling.

The chosen method affects the ambient temperature value (T_{rate}) which should be used for any necessary derating to ensure sufficient cooling for the whole of the drive.

The ambient temperature for the four different combinations is defined below:

1. Totally enclosed with no air flow (<2 m/s) over the drive
 $T_{rate} = T_{int} + 5\text{ }^{\circ}\text{C}$
2. Totally enclosed with air flow (>2 m/s) over the drive
 $T_{rate} = T_{int}$
3. Through panel mounted with no airflow (<2 m/s) over the drive
 $T_{rate} = \text{the greater of } T_{ext} + 5\text{ }^{\circ}\text{C}, \text{ or } T_{int}$
4. Through panel mounted with air flow (>2 m/s) over the drive
 $T_{rate} = \text{the greater of } T_{ext} \text{ or } T_{int}$

Where:

T_{ext} = Temperature outside the cabinet

T_{int} = Temperature inside the cabinet

T_{rate} = Temperature used to select current rating from tables in Chapter 5 *Technical data* on page 77.

3.7 Heatsink fan operation

The drive is ventilated by an internal heatsink mounted fan. The fan housing forms a baffle plate, channelling the air through the heatsink chamber. Thus, regardless of mounting method (surface mounting or through-panel mounting), the installing of additional baffle plates is not required.

Ensure the minimum clearances around the drive are maintained to allow air to flow freely.

The heatsink fan on all sizes is a variable speed fan. The drive controls the speed at which the fan runs based on the temperature of the heatsink and the drive's thermal model system. The maximum speed at which the fan operates can be limited in Pr **06.045**. This could incur an output current derating. Refer to section 3.13.1 *Fan removal procedure* on page 45 for information on fan removal.

3.8 Enclosing standard drive for high environmental protection

An explanation of environmental protection rating is provided in section 5.1.10 *IP / UL Rating* on page 86.

The standard drive is rated to IP20 pollution degree 2 (dry, non-conductive contamination only) (NEMA 1). However, it is possible to configure the drive to achieve IP65 rating (sizes 3 to 4) (NEMA 12) at the rear of the heatsink for through-panel mounting (some current derating is required). Refer to Chapter 5 *Technical data* on page 77.

This allows the front of the drive, along with various switchgear, to be housed in a high IP enclosure with the heatsink protruding through the panel to the external environment. Thus, the majority of the heat generated by the drive is dissipated outside the enclosure maintaining a reduced temperature inside the enclosure. This also relies on a good seal being made between the heatsink and the rear of the enclosure using the gaskets provided.

Figure 3-15 Example of IP65 (sizes 3 to 4) (NEMA 12) through-panel layout

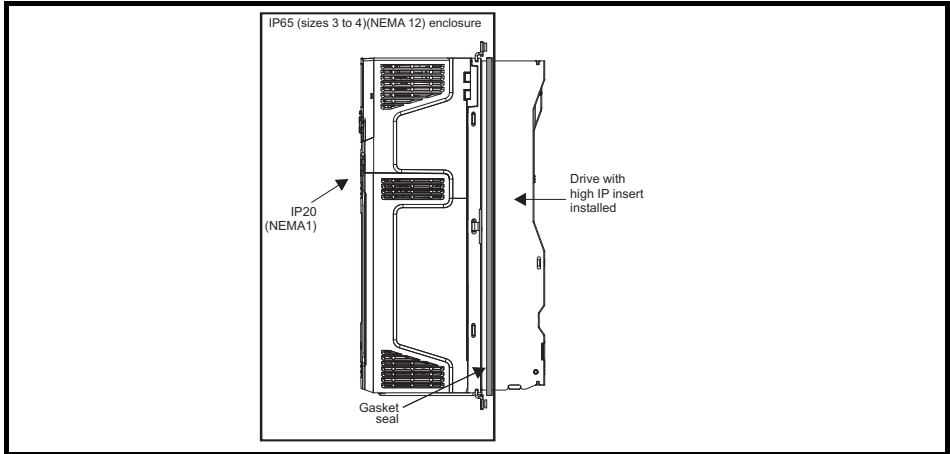

The main gasket should be installed as shown in Figure 3-16.

On drive sizes 3 and 4, in order to achieve the high IP rating at the rear of the heatsink it is necessary to seal a heatsink vent by installing the high IP insert as shown in Figure 3-18 and Figure 3-19 on page 37.

NOTE

The heatsink fans have conformal coated PCBs and have sealant at cable entry points. This means that the electronics of the fan are rated to IP54. Dripping, splashing or sprayed water can impede the operation of the fan, therefore if the environment is such that the fan may be subjected to more than occasional dripping or sprayed water while operational, then suitable drip protection covers should be employed.

Figure 3-16 Installing the gasket

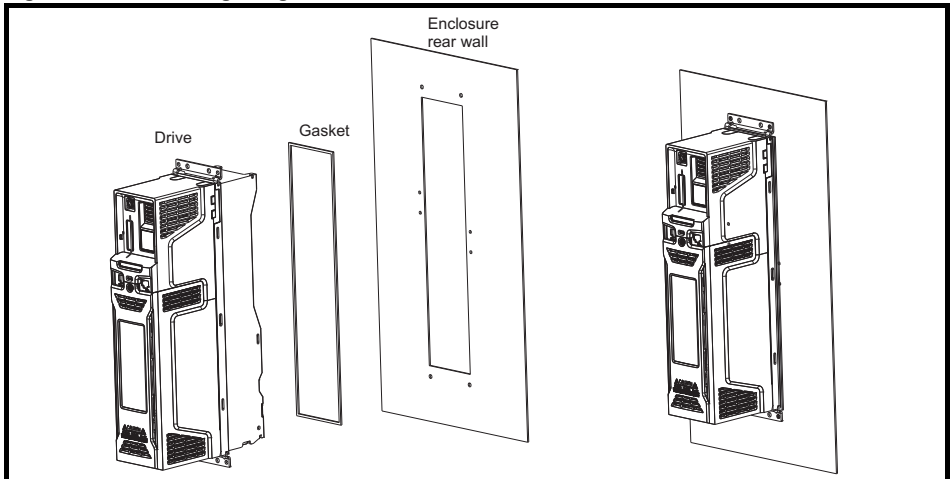

To seal the space between the drive and the backplate, use two sealing brackets as shown in Figure 3-17.

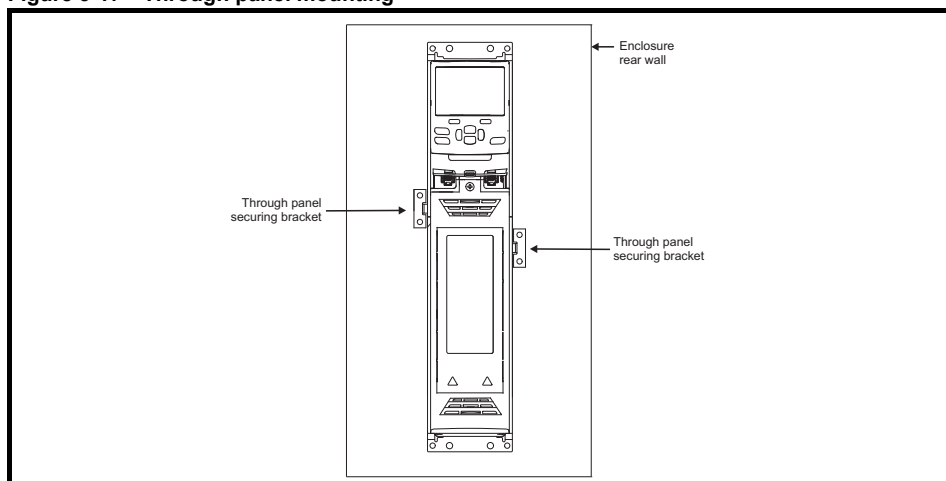
Figure 3-17 Through panel mounting

3.9 Installation of high IP insert for size 3 and 4

The standard drive is rated to IP20 pollution degree 2 (dry, non-conductive contamination only) (NEMA 1). However, it is possible to configure the drive to achieve IP65 rating sizes 3 to 4 (NEMA 12) at the rear of the heatsink for through-panel mounting (some current derating is required).

On drive sizes 3 and 4, in order to achieve the high IP rating at the rear of the heatsink it is necessary to seal a heatsink vent by installing the high IP insert as shown in Figure 3-18.

Figure 3-18 Installation of high IP insert for size 3

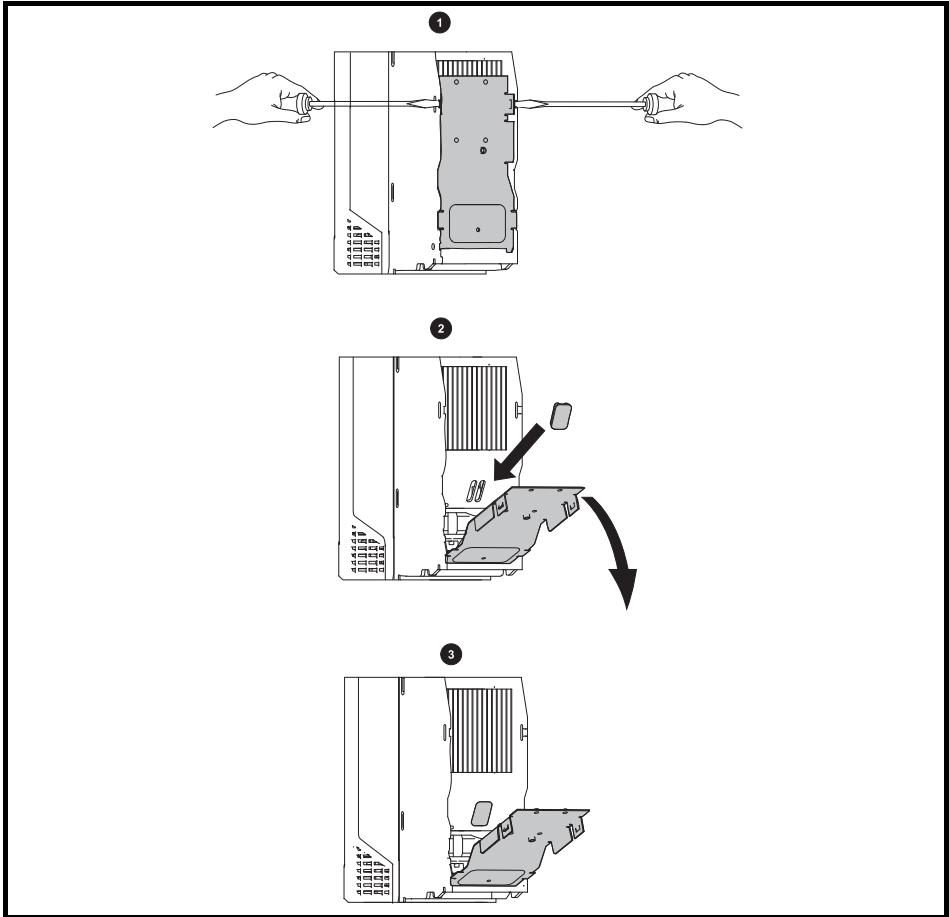

1. To install the high IP insert, firstly place a flat head screwdriver into the slots highlighted (1).
2. Pull the hinged baffle down to expose the ventilation hole, install the high IP insert into the ventilation hole in the heatsink (2).
3. Ensure the high IP insert is securely installed by firmly pressing it into place (3).
4. Close the hinged baffle as shown (1).
5. To remove the high IP insert, reverse the above instructions.

The guidelines in Table 3-4 should be followed.

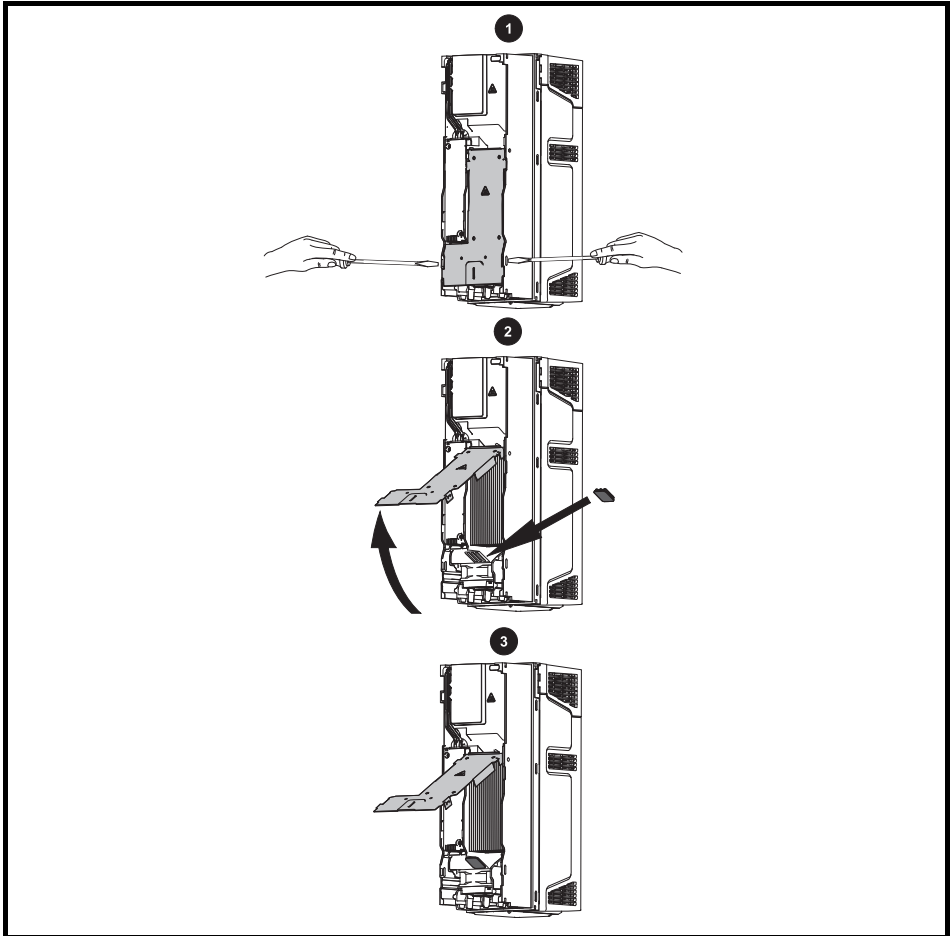
Figure 3-19 Installation of high IP insert for size 4

1. To install the high IP insert, firstly place a flat head screwdriver into the slots highlighted (1).
2. Pull the hinged baffle up to expose the ventilation hole, install the high IP insert into the ventilation hole in the heatsink (2).
3. Ensure the high IP insert is securely installed by firmly pressing it into place (3).
4. Close the hinged baffle as shown (1).
5. To remove the high IP insert, reverse the above instructions.

The guidelines in Table 3-4 should be followed.

Table 3-4 Environmental considerations

Environment	High IP insert	Comments
Clean	Not installed	
Dry, dusty (non-conductive)	Installed	Regular cleaning recommended
Dry, dusty (conductive)	Installed	
IP65 compliance	Installed	

NOTE A current derating must be applied to the drive if the high IP insert is installed. Derating information is provided in Chapter 5 *Technical data* on page 77

Failure to do so may result in nuisance tripping.

NOTE When designing an IP65 (NEMA 12) enclosure (Figure 3-15 *Example of IP65 (sizes 3 to 4) (NEMA 12) through-panel layout* on page 34), consideration should be made to the dissipation from the front of the drive.

Table 3-5 Power losses from the front of the drive when through-panel mounted

Frame size	Power loss
3	≤ 50 W
4	≤ 75 W

3.10 Size 3 and 4 internal braking resistor

Size 3 and 4 have been designed with an optional space-saving heatsink mounted resistor. The resistor can be installed within the heatsink fins of the drive. When the heatsink resistor is used, an external thermal protection device is not required as the resistor is designed such that it will fail safely under any fault conditions. The in-built software overload protection is set-up at default to protect the resistor. The resistor is rated to IP54 (NEMA 12).

Table 3-6 Size 3 and 4 internal braking resistor part numbers

Frame size	Part number
3	1220-2752
4	1299-0003



The internal / heatsink mounted braking resistors must only be used with the following drives. Brake resistor 1220-2752 must only be used with size 3 drives. Brake resistor 1299-0003 must only be used with size 4 drives.

3.10.1 Internal braking resistor installation instructions

Figure 3-20 Brake resistor installation on size 3

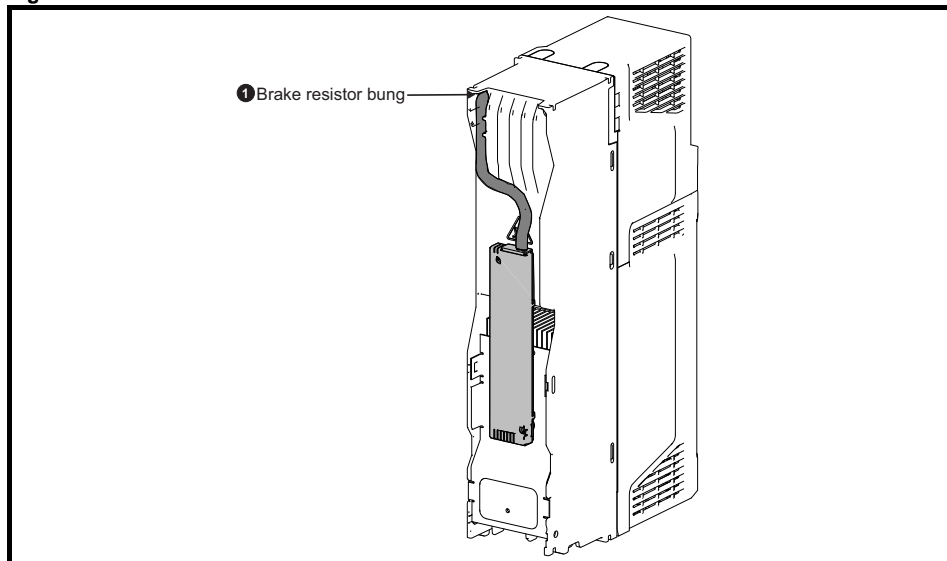

- Remove the terminal covers.
- Remove the internal EMC filter as shown in Figure 4-11 *Removal of the size 3 internal EMC filter* on page 67.
- Remove the brake resistor bung (1) from the hole in the chassis, the closed end of the bung will need to be pierced so that the cable has access to be routed through.
- Feed brake resistor bung onto outer insulation of brake resistor cable. The wider end of the bung should be inserted first. The Narrow end should align with end of insulation.
- Install the braking resistor to the heatsink using the captive screws. The screws should be tightened to a maximum torque of 2 N m (1.5 lb ft).
- Route the cables through the provided hole at the rear of the heatsink as shown in Figure 3-20 and take the cable out from the front side of the drive. Ensure the cables are routed between the fins of the heatsink, and the cables are not trapped between the heatsink fins and the resistor.
- Crimp the cable ends and make appropriate connections. The brake terminals must be tightened to a maximum torque of 2 N m (1.5 lb ft).
- Replace the terminal covers on the drive, tighten to a maximum torque of 1 N m (0.7 lb ft).

Figure 3-21 Brake resistor installation on size 4

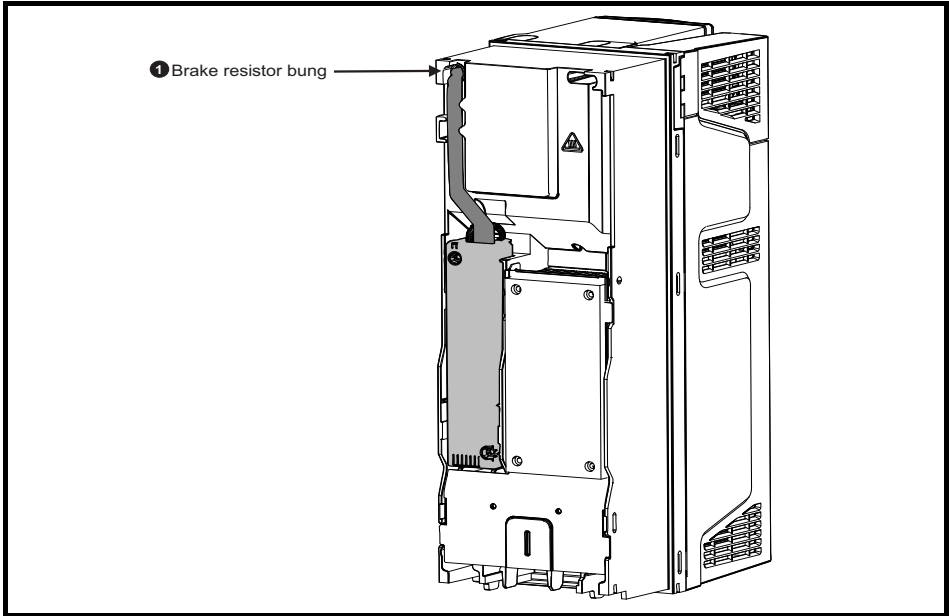

- Remove the terminal covers.
- Remove the brake resistor bung from the hole (1) in the chassis, the closed end of the bung will need to be pierced so that the cable has access to be routed through.
- Feed brake resistor bung onto outer insulation of brake resistor cable. The wider end of the bung should be inserted first. The Narrow end should align with end of insulation.
- Install the braking resistor to the heatsink using the captive screws. The screws should be tightened to a maximum torque of 2 N m (1.5 lb ft).
- Route the cables through the provided hole at the rear of the heatsink as shown in Figure 3-21 and take the cable out from the front side of the drive. Ensure the cables are routed between the fins of the heatsink, and the cables are not trapped between the heatsink fins and the resistor.
- Crimp the cable ends and make appropriate connections. The brake terminals must be tightened to a maximum torque of 2 N m (1.5 lb ft).
- Replace the terminal covers on the drive, tighten to a maximum torque of 1 N m (0.7 lb ft).

3.10.2 External brake resistor

External brake resistors are available from Nidec Industrial Automation for drive sizes 3 to 4. They can be mounted in the enclosure as per mounting recommendation in Figure 3-13 *Enclosure layout* on page 29 using mounting bracket part number 6541-0187 (shown in Figure 3-23). Figure 3-22 below shows the brake resistor mounted on the mounting bracket. Two M4 screws and nuts (2) can be used to fix the brake resistor to the mounting bracket. One M4 nut with washer (1) is provided to use for the ground connection. The brake resistor is equipped with a thermal switch, the thermal switch should be integrated in the control circuit by the user.

Figure 3-22 Brake resistor with the mounting bracket

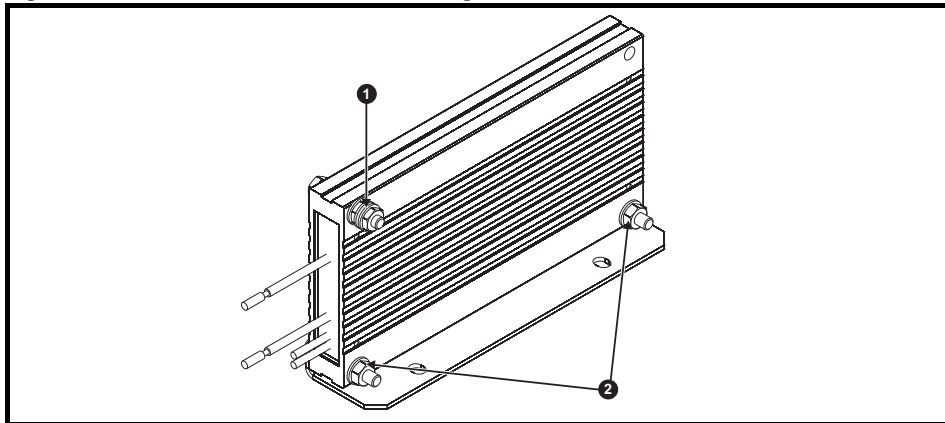

1. Ground connection (1 x M4 nut and washer).
2. Attaching the brake resistor to the mounting bracket (using 2 x M4 screws and nuts).

Figure 3-23 Mounting bracket dimensions

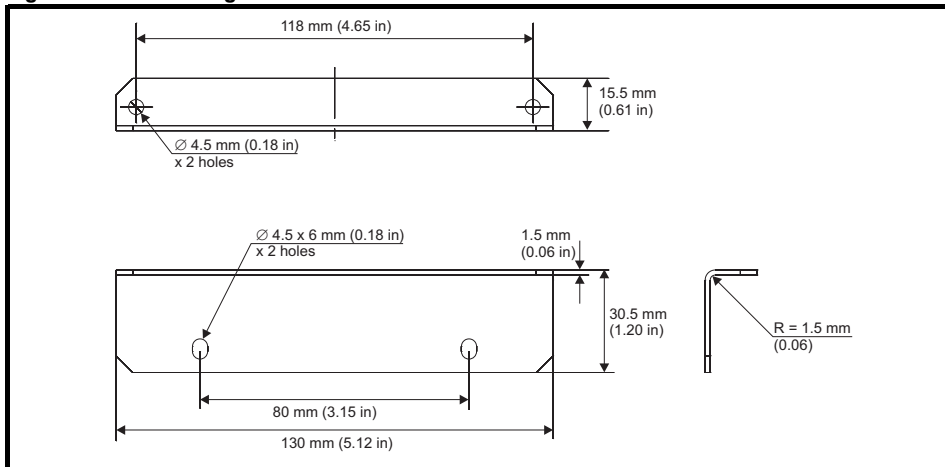
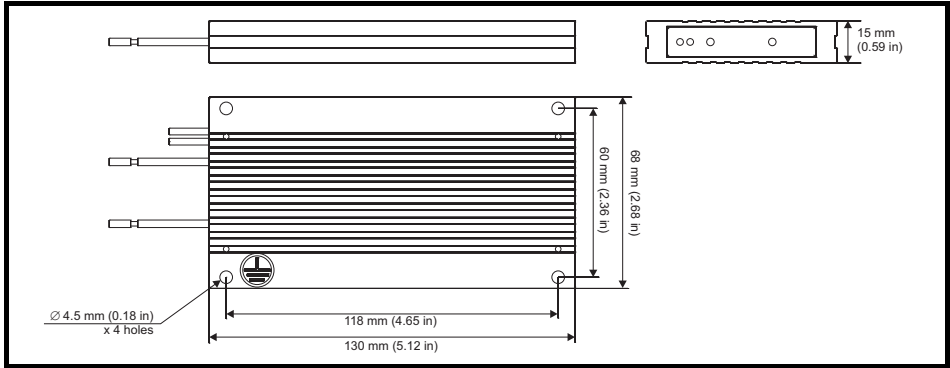

Figure 3-24 Brake resistor dimensions



3.11 External EMC filter

The external EMC filter for size 3 and 4 drives can be footprint mounted or bookcase mounted as shown in Figure 3-25 and Figure 3-26.

Figure 3-25 Footprint mounting the EMC filter

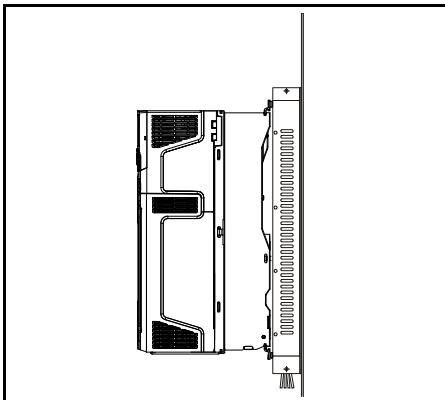
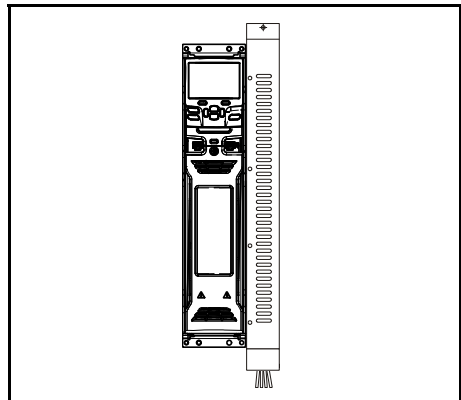

Figure 3-26 Bookcase mounting the EMC filter



3.11.1 Optional external EMC filters

Table 3-7 EMC filter cross reference

Model	CT part number
200 V	
03200050 to 03200106	4200-3230
04200137 to 04200185	4200-0272
400 V	
03400025 to 03400100	4200-3480
04400150 to 04400172	4200-0252

3.11.2 EMC filter ratings

Table 3-8 Optional external EMC filter details

CT part number	Maximum continuous current		Voltage rating		IP rating	Power dissipation at rated current		Ground leakage		Discharge resistors MΩ
	@ 40 °C (104 °F)	@ 50 °C (122 °F)	IEC	UL		@ 40 °C (104 °F)	@ 50 °C (122 °F)	Balanced supply phase-to-phase and phase-to-ground mA	Worst case mA	
	A	A	V	V		W	W			
4200-3230	20	18.5	250	300	20	20	17	2.4	60	1.68
4200-3480	16	15	528	600		13	11	10.7	151	
4200-0272	27	24.8	250	300		33	28	6.8	137	
4200-0252	25	23	528	600		28	24	11.1	182	

Figure 3-27 External EMC filter

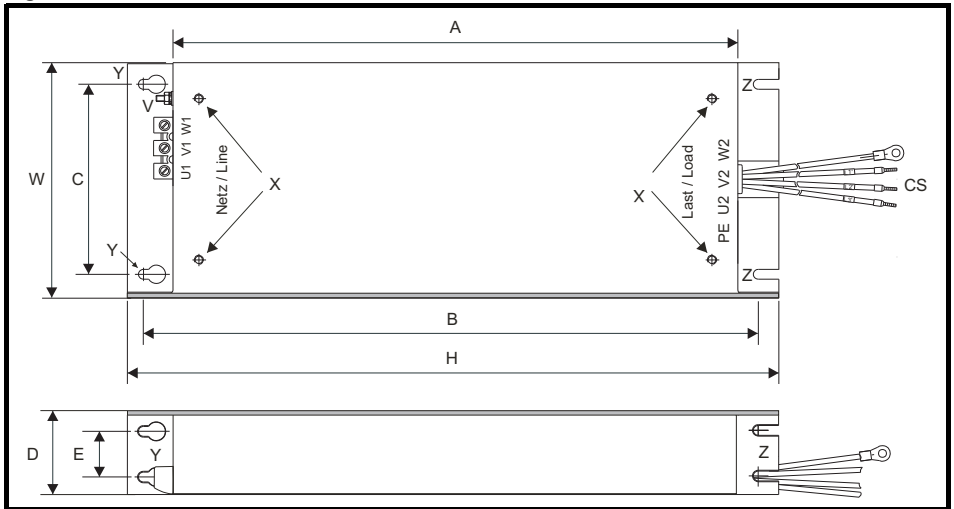

- V: Ground stud
- X: Threaded holes for footprint mounting of the drive
- Y: Footprint mounting hole diameter
- Z: Bookcase mounting slot diameter.
- CS: Cable size

Table 3-9 Size 3 external EMC filter dimensions

CT part number	A	B	C	D	E	H	W	V/X	Y/Z	CS
4200-3230	384 mm (15.12 in)	414 mm (16.30 in)	56 mm (2.21 in)	41 mm (1.61 in)		426 mm (16.77 in)	83 mm (3.27 in)	M5	5.5 mm (0.22 in)	2.5 mm ² (14 AWG)
4200-3480										

Table 3-10 Size 4 external EMC filter dimensions

CT part number	A	B	C	D	E	H	W	V/X	Y/Z	CS
4200-0272	395 mm (15.55 in)	425 mm (16.73 in)	100 mm (3.94 in)	60 mm (2.36 in)	33 mm (1.30 in)	437 mm (17.2 in)	123 mm (4.84 in)	M6	6.5 mm (0.26 in)	6 mm ² (10 AWG)
4200-0252										

3.11.3 EMC filter torque settings

Table 3-11 Optional external EMC Filter terminal data

CT part number	Power connections		Ground connections	
	Max cable size	Max torque	Ground stud size	Max torque
4200-3230	4 mm ² (12 AWG)	0.8 N m (0.59 lb ft)	M5	2.5 N m (1.8 lb ft)
4200-3480				
4200-0252	6 mm ² (10 AWG)	1.8 N m (0.88 lb ft)	M6	5.0 N m (3.7 lb ft)
4200-0272				

Table 3-12 Fastener details for drive footprint mounting on external EMC filter

Type	Size 3	Size 4
Screw specification	Property class 8.8. standard metric, coarse thread	
Thread size	M5	M6
Length (mm)	12	12
Washer	Helical spring, split spring or conical spring	
Torque (N m)	6.0	10.0

3.12 Terminal size and torque settings

Table 3-13 Drive control and relay terminal data

Model	Connection type	Torque setting
All	Plug-in terminal block	0.5 N m (0.4 lb ft)

Table 3-14 Drive power terminal data

Frame size	AC and motor terminals		DC and braking		Ground terminal	
	Recommended	Maximum	Recommended	Maximum	Recommended	Maximum
3 and 4	Plug-in terminal block		T20 Torx (M4)		T20 Torx (M4) / M4 Nut (7 mm AF)	
	0.7 N m (0.5 lb ft)	0.8 N m (0.6 lb ft)	2.0 N m (1.4 lb ft)	2.5 N m (1.8 lb ft)	2.0 N m (1.4 lb ft)	2.5 N m (1.8 lb ft)

3.13 Routine maintenance

The drive should be installed in a cool, clean, well ventilated location. Contact of moisture and dust with the drive should be prevented. Regular checks of the following should be carried out to ensure drive / installation reliability are maximized:

Environment	
Ambient temperature	Ensure the enclosure temperature remains at or below maximum specified
Dust	Ensure the drive remains dust free – check that the heatsink and drive fan are not gathering dust. The lifetime of the fan is reduced in dusty environments.
Moisture	Ensure the drive enclosure shows no signs of condensation
Enclosure	
Enclosure door filters	Ensure filters are not blocked and that air is free to flow
Electrical	
Screw connections	Ensure all screw terminals remain tight
Crimp terminals	Ensure all crimp terminals remains tight – check for any discoloration which could indicate overheating
Cables	Check all cables for signs of damage

3.13.1 Fan removal procedure

Figure 3-28 Removal of the size 3 and 4 heatsink fan (size 3 shown)

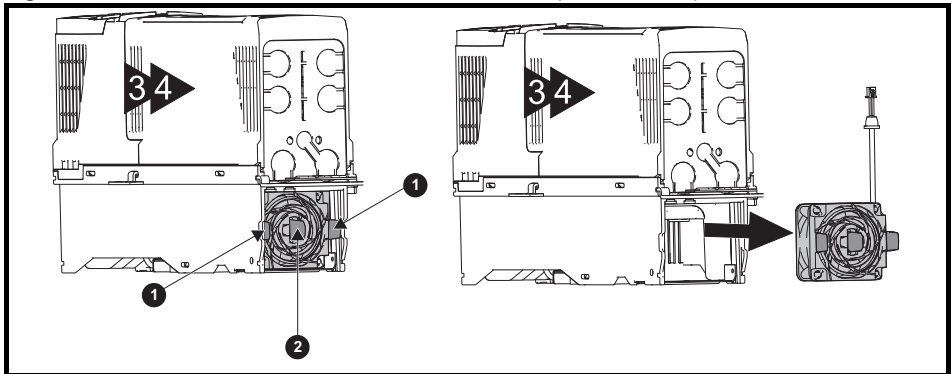

Ensure the fan cable is disconnected from the drive prior to attempting fan removal.

1. Press the two tabs inwards to release the fan from the drive frame.
2. Using the central fan tab, withdraw the fan assembly from the drive housing.

Replace the fan by reversing the above instructions.

NOTE If the drive is surface mounted using the outer holes on the mounting bracket, then the heatsink fan can be replaced without removing the drive from the backplate.

Table 3-15 Heatsink fan part numbers

Model	Fan part number
Size 3	3251-0029
Size 4	3251-0245

4 Electrical installation



Electric shock risk

The voltages present in the following locations can cause severe electric shock and may be lethal:

- AC supply cables and connections
 - DC and brake cables, and connections
 - Output cables and connections
 - Many internal parts of the drive, and external option units
- Unless otherwise indicated, control terminals are single insulated and must not be touched.



Isolation device

The AC and / or DC power supply must be disconnected from the drive using an approved isolation device before any cover is removed from the drive or before any servicing work is performed.



STOP function

The STOP function does not remove dangerous voltages from the drive, the motor or any external option units.



Safe Torque Off function

The Safe Torque Off function does not remove dangerous voltages from the drive, the motor or any external option units.



Stored charge

The drive contains capacitors that remain charged to a potentially lethal voltage after the AC and / or DC power supply has been disconnected. If the drive has been energized, the AC and / or DC power supply must be isolated at least ten minutes before work may continue. Normally, the capacitors are discharged by an internal resistor. Under certain, unusual fault conditions, it is possible that the capacitors may fail to discharge, or be prevented from being discharged by a voltage applied to the output terminals. If the drive has failed in a manner that causes the display to go blank immediately, it is possible the capacitors will not be discharged. In this case, consult Nidec Industrial Automation or their authorized distributor.



Equipment supplied by plug and socket

Special attention must be given if the drive is installed in equipment which is connected to the AC supply by a plug and socket. The AC supply terminals of the drive are connected to the internal capacitors through rectifier diodes which are not intended to give safety isolation. If the plug terminals can be touched when the plug is disconnected from the socket, a means of automatically isolating the plug from the drive must be used (e.g. a latching relay).



Permanent magnet motors

Permanent magnet motors generate electrical power if they are rotated, even when the supply to the drive is disconnected. If that happens then the drive will become energized through its motor terminals. If the motor load is capable of rotating the motor when the supply is disconnected, then the motor must be isolated from the drive before gaining access to any live parts.

4.1 Power and ground connections

Figure 4-1 Size 3 power and ground connections

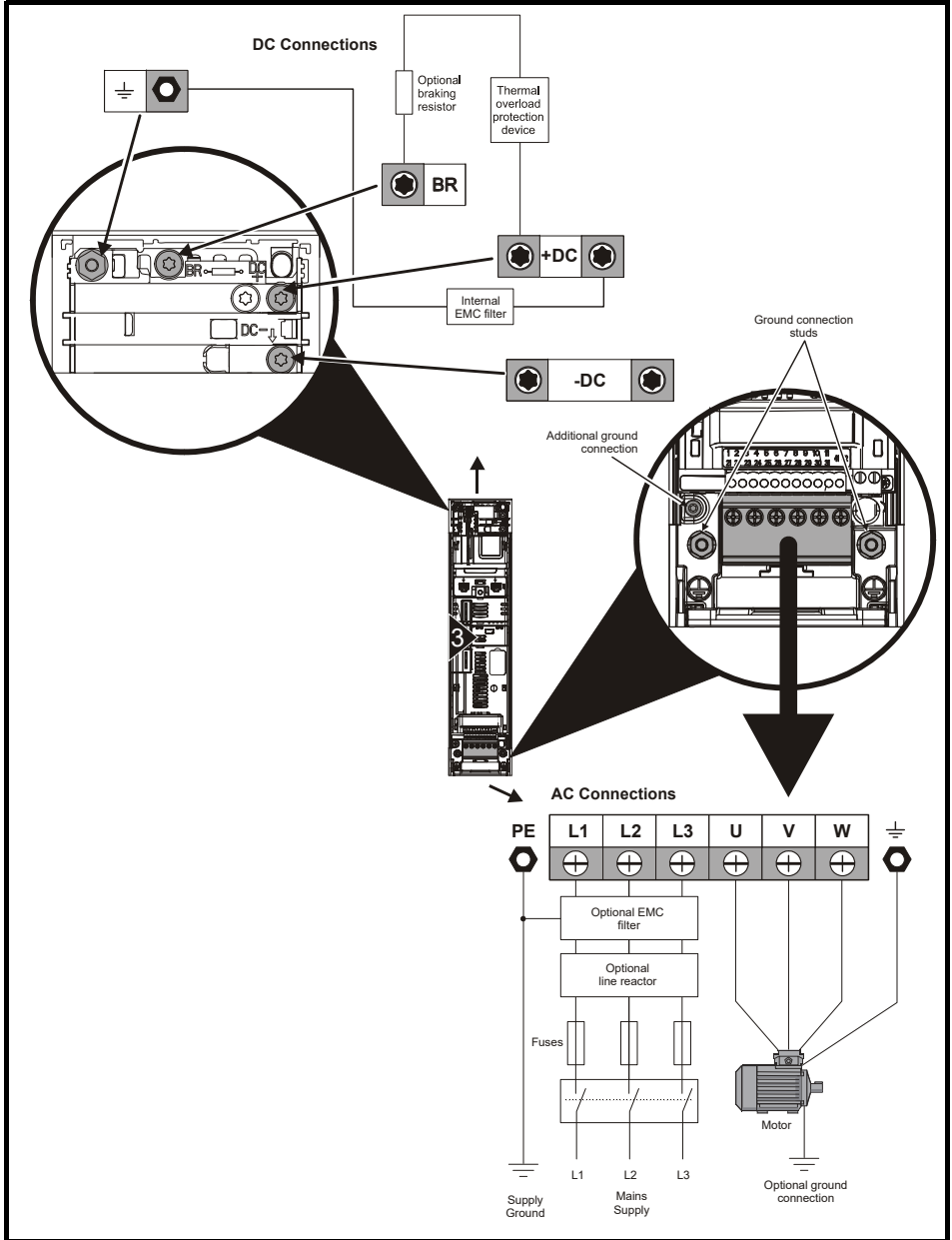
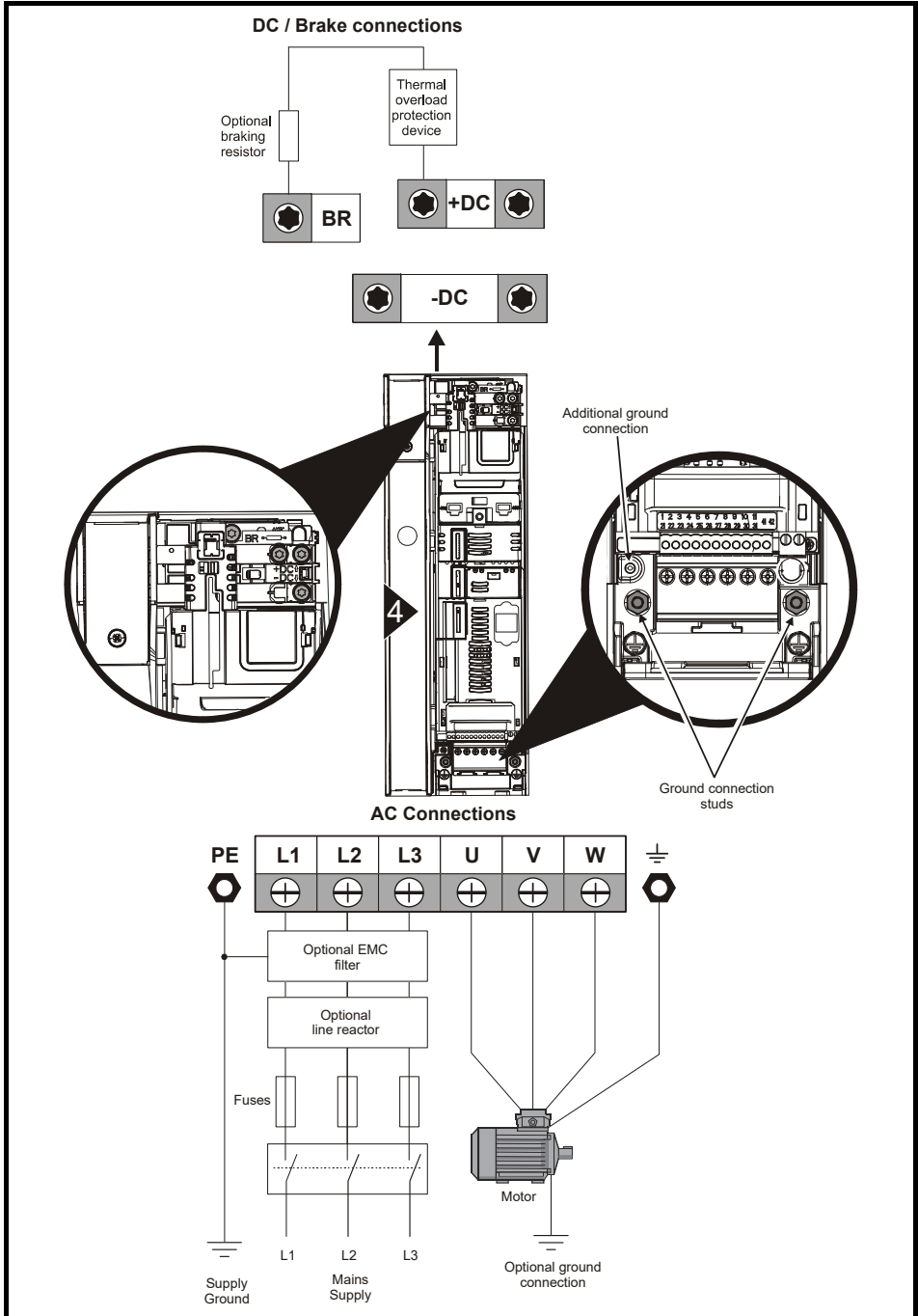

Figure 4-2 Size 4 power and ground connections



4.1.1 Ground connections



Electrochemical corrosion of grounding terminals

Ensure that grounding terminals are protected against corrosion i.e. as could be caused by condensation.

The drive must be connected to the system ground of the AC supply. The ground wiring must conform to local regulations and codes of practice.

NOTE For further information on ground cable sizes, refer to Table 2-3 *Protective ground cable ratings* on page 15.

On size 3 and 4, the supply and motor ground connections are made using the M4 studs located either side of the drive near the plug-in power connectors. See Figure 4-1 and Figure 4-2 for details.



The ground loop impedance must conform to the requirements of local safety regulations. The drive must be grounded by a connection capable of carrying the prospective fault current until the protective device (fuse, etc.) disconnects the AC supply. The ground connections must be inspected and tested at appropriate intervals.

4.2 AC Supply requirements

AC supply voltage:

200 V drive: 200 V to 240 V \pm 10 %

400 V drive: 380 V to 480 V \pm 10 %

Number of phases: 3

Maximum supply imbalance: 2 % negative phase sequence (equivalent to 3 % voltage imbalance between phases).

Frequency range: 45 to 66 Hz

For UL compliance only, the maximum supply symmetrical fault current must be limited to 100 kA

Table 4-1 Supply fault current used to calculate maximum input currents

Model	Symmetrical fault level (kA)
All	100

4.2.1 Supply types

All drives are suitable for use on any supply type i.e TN-S, TN-C-S, TT and IT. Drives are suitable for use on supplies of installation category III and lower, according to IEC60664-1. This means they may be connected permanently to the supply at its origin in a building, but for outdoor installation additional over-voltage suppression (transient voltage surge suppression) must be provided to reduce category IV to category III.



Operation with IT (ungrounded) supplies:

Special attention is required when using internal or external EMC filters with ungrounded supplies, because in the event of a ground (earth) fault in the motor circuit the drive may not trip and the filter could be over-stressed. In this case, either the filter must not be used (removed) or additional independent motor ground fault protection must be provided. For instructions on removal, refer to Figure 4-11 and Figure 4-12 on page 67. For details of ground fault protection contact the supplier of the drive.

A ground fault in the supply has no effect in any case. If the motor must continue to run with a ground fault in its own circuit then an input isolating transformer must be provided and if an EMC filter is required it must be located in the primary circuit. Unusual hazards can occur on ungrounded supplies with more than one source, for example on ships. Contact the supplier of the drive for more information.



If an SI-Applications Plus module is installed in the drive, then the drive must not be used on a corner-grounded or centre-grounded delta supply if the supply voltage is above 300 V. If this is required, please contact the supplier of the drive for more information.

4.2.2 Supplies requiring line reactors

Input line reactors reduce the risk of damage to the drive resulting from poor phase balance or severe disturbances on the supply network.

Where line reactors are to be used, reactance values of approximately 2 % are recommended. Higher values may be used if necessary, but may result in a loss of drive output (reduced torque at high speed) because of the voltage drop.

For all drive ratings, 2 % line reactors permit drives to be used with a supply unbalance of up to 3.5 % negative phase sequence (equivalent to 5% voltage imbalance between phases).

Severe disturbances may be caused by the following factors, for example:

- Power factor correction equipment connected close to the drive.
- Large DC drives having no or inadequate line reactors connected to the supply.
- Across the line (DOL) started motor(s) connected to the supply such that when any of these motors are started, the voltage dip exceeds 20 %.

Such disturbances may cause excessive peak currents to flow in the input power circuit of the drive. This may cause nuisance tripping, or in extreme cases, failure of the drive.

Drives of low power rating may also be susceptible to disturbance when connected to supplies with a high rated capacity.

Line reactors are particularly recommended for use with the following drive models when one of the above factors exists, or when the supply capacity exceeds 175 kVA:

03200050, 03200066, 03200080, 03200106,
03400025, 03400031, 03400045, 03400062

Model sizes 03400078 to 04400172 have an internal DC choke so they do not require AC line reactors except for cases of excessive phase unbalance or extreme supply conditions.

When required, each drive must have its own reactor(s). Three individual reactors or a single three-phase reactor should be used.

Reactor current ratings

The current rating of the line reactors should be as follows:

Continuous current rating:

Not less than the continuous input current rating of the drive

Repetitive peak current rating:

Not less than twice the continuous input current rating of the drive

Table 4-2 2 % line reactors

Drive model number	Voltage rating V	Line reactor designation	CT Part number	Line reactor current rating A	Inductance mH	Weight kg	Length mm	Width mm	Height mm
03200050	200	INL2001	4401-0143	13.5	0.79	1.8	156	70	125
03200066	200	INL2001	4401-0143	13.5	0.79	1.8	156	70	125
03200080	200	INL2002	4401-0144	20.6	0.48	2.4	156	80	125
03200106	200	INL2002	4401-0144	20.6	0.48	2.4	156	80	125
04200137	200	INL2002	4401-0144	20.6	0.48	2.4	156	80	125
04200185	200	INL2003	4401-0145	26.8	0.32	2.5	156	80	125
03400025	400	INL4001	4401-0148	6.6	2.94	1.3	80	75	130
03400031	400	INL4001	4401-0148	6.6	2.94	1.3	80	75	130
03400045	400	INL4002	4401-0149	9.1	1.62	1.8	156	70	125
03400062	400	INL4011	4401-0234	13	1.12	2.5	156	80	125
03400078	400	INL4011	4401-0234	13	1.12	2.5	156	80	125
03400100	400	INL4003	4401-0151	15.8	1.05	2.6	156	80	125
04400150	400	INL4004	4401-0152	18.7	0.79	3.5	156	60	145
04400172	400	INL4005	4401-0153	24.3	0.61	4.9	156	75	145

4.2.3 Input inductor calculation

To calculate the inductance required (at Y %), use the following equation:

$$L = \frac{Y}{100} \times \frac{V}{\sqrt{3}} \times \frac{1}{2\pi f I}$$

Where:

I = drive rated input current (A)

L = inductance (H)

f = supply frequency (Hz)

V = voltage between lines

4.3 Supplying the drive with DC

All drive sizes have the option to be powered from an external DC power supply. Refer to section 4.1 *Power and ground connections* on page 47 to identify the location of DC supply connections.

The DC supply connections for size 3 and 4 are located under the DC / Braking terminal cover.

Figure 4-3 shows DC supply connections and cable routing.

Figure 4-3 DC supply connections (size 3 shown)

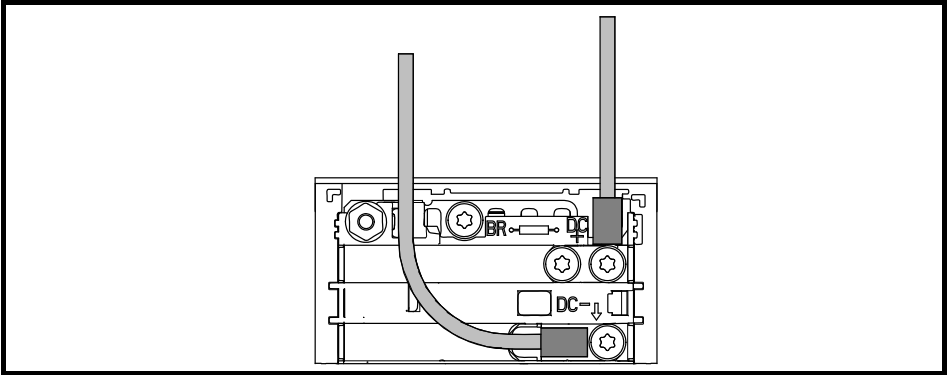

NOTE The Internal EMC filter and plastics have been removed from the above image to demonstrate the routing of the DC cables.

4.4 DC bus paralleling

DC bus paralleling using standard cable / busbars is supported by all frame sizes.

On frame sizes 3 and 4, terminal and enclosure design enables the DC bus of a number of drives to be connected together using pre-made busbars. The diagram below shows how the busbar links connect the DC bus of several drives together.

The connecting of the DC bus between several drives is typically used to:

1. Return energy from a drive which is being overhauled by the load to a second motoring drive.
2. Allow the use of one braking resistor to dissipate regenerative energy from several drives.

Figure 4-4 DC bus paralleling (size 3 shown)

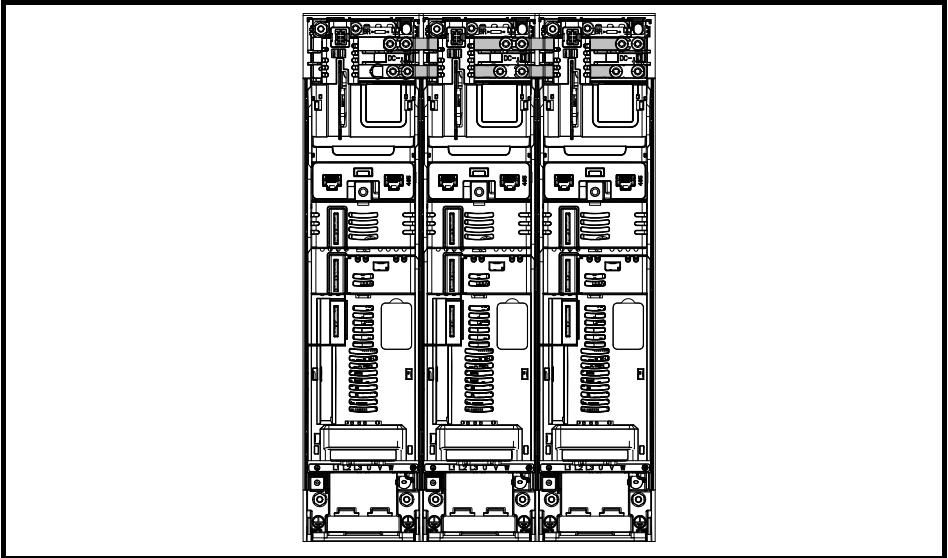

There are limitations to the combinations of drives which can be used in this configuration.

For application data, contact the supplier of the drive.

NOTE The DC bus paralleling kit is not supplied with the drive but available to order from the supplier of the drive.

Table 4-3 DC bus paralleling kit part numbers

Size	CT part number
3	3470-0048
4	3470-0061

4.5 24 Vdc supply

The 24 Vdc supply connected to control terminals 1 & 2* provides the following functions:

- It can be used to supplement the drive's own internal 24 V supply when multiple option modules are being used and the current drawn by these module is greater than the drive can supply.
- It can be used as a back-up power supply to keep the control circuits of the drive powered up when the line power supply is removed. This allows any fieldbus modules, application modules, encoders or serial communications to continue to operate.
- It can be used to commission the drive when the line power supply is not available, as the display operates correctly. However, the drive will be in the Under voltage trip state unless either line power supply or low voltage DC operation is enabled, therefore diagnostics may not be possible. (Power down save parameters are not saved when using the 24 V back-up power supply input).
- If the DC bus voltage is too low to run the main SMPS in the drive, then the 24 V supply can be used to supply all the low voltage power requirements of the drive. *Low Under Voltage Threshold Select* (06.067) must also be enabled for this to happen.

Table 4-4 24 Vdc Supply connections

Function	Sizes 3 and 4
Supplement the drive's internal supply and back-up supply for the control circuit	Terminal 1, 2*

* Terminal 9 on *Unidrive M702* and *Unidrive HS72*.

The working voltage range of the control 24 V power supply is as follows:

1	0 V
2	+24 Vdc
Nominal operating voltage	24.0 Vdc
Minimum continuous operating voltage	19.2 V
Maximum continuous operating voltage	28.0 V
Minimum start up voltage	21.6 V
Maximum power supply requirement at 24 V	40 W
Recommended fuse	3 A, 50 Vdc

Minimum and maximum voltage values include ripple and noise. Ripple and noise values must not exceed 5 %.

4.6 Low voltage operation

With the addition of a 24 Vdc power supply to supply the control circuits, the drive is able to operate from a low voltage DC supply with a range from 24 Vdc to the maximum DC volts. It is possible for the drive to go from operating on a normal line power supply voltage to operating on a much lower supply voltage without interruption.

Going from low voltage operation to normal mains operation requires the inrush current to be controlled. This may be provided externally. If not, the drive supply can be interrupted to utilise the normal soft starting method in the drive.

To fully exploit the new low voltage mode of operation, the under voltage trip level is now user programmable. For application data, contact the supplier of the drive.

The working voltage range of the low voltage DC power supply is as follows:

Size 3 to 4

Minimum continuous operating voltage:	26 V
Minimum start up voltage:	32 V
Maximum over voltage trip threshold:	230 V drives: 415 V 400 V drives: 830 V

4.7 Fan power supply

The fans installed on all drive sizes are supplied internally by the drive.

4.8 Ratings

See section 2.4 *Ratings* on page 14.

Maximum continuous input current

The values of maximum continuous input current are given to aid the selection of cables and fuses. These values are stated for the worst case condition with the unusual combination of stiff supply with high imbalance. The value stated for the maximum continuous input current would only be seen in one of the input phases. The current in the other two phases would be significantly lower.

The values of maximum input current are stated for a supply with a 2 % negative phase-sequence imbalance and rated at the maximum supply fault current given in section 4.2 *AC Supply requirements* on page 49.

The nominal cable sizes given in section 2.4 *Ratings* on page 14 are only a guide. Refer to local wiring regulations for the correct size of cables. In some cases a larger cable is required to avoid excessive voltage drop.

NOTE

The nominal output cable sizes in section 2.4 *Ratings* on page 14 assume that the motor maximum current matches that of the drive. Where a motor of reduced rating is used the cable rating may be chosen to match that of the motor. To ensure that the motor and cable are protected against over-load, the drive must be programmed with the correct motor rated current.



WARNING

Fuses

The AC supply to the drive must be installed with suitable protection against overload and short-circuits. Nominal fuse ratings are shown in section 2.4 *Ratings* on page 14. Failure to observe this requirement will cause risk of fire.

A fuse or other protection must be included in all live connections to the AC supply.

Fuse types

The fuse voltage rating must be suitable for the drive supply voltage.

4.8.1 Main AC supply contactor

The recommended AC supply contactor type for size 3 to 4 is AC1.

4.9 Output circuit and motor protection

The output circuit has fast-acting electronic short-circuit protection which limits the fault current to typically no more than five times the rated output current, and interrupts the current in approximately 20 μ s. No additional short-circuit protection devices are required.

The drive provides overload protection for the motor and its cable. For this to be effective, *Rated Current (00.046)* must be set to suit the motor.



Rated Current (00.046) must be set correctly to avoid a risk of fire in the event of motor overload.

There is also provision for the use of a motor thermistor to prevent over-heating of the motor, e.g. due to loss of cooling.

4.9.1 Motor cable types

Since capacitance in the motor cable causes loading on the output of the drive, ensure the cable length does not exceed the values given in Table 5-21 and Table 5-22.

Use 105 °C (221 °F) (UL 60/75 °C temp rise) PVC-insulated cable with copper conductors having a suitable voltage rating, for the following power connections:

- AC supply to external EMC filter (when used)
- AC supply (or external EMC filter) to drive
- Drive to motor
- Drive to braking resistor

4.9.2 High-capacitance / reduced diameter cables

The maximum cable length is reduced from that shown in Table 5-21 and Table 5-22 if high capacitance or reduced diameter motor cables are used.

Most cables have an insulating jacket between the cores and the armor or shield; these cables have a low capacitance and are recommended. Cables that do not have an insulating jacket tend to have high capacitance; if a cable of this type is used, the maximum cable length is half that quoted in the tables, (Figure 4-5 shows how to identify the two types).

Figure 4-5 Cable construction influencing the capacitance

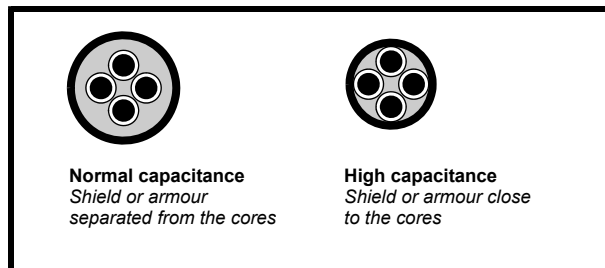

The maximum motor cable lengths specified in section 5.1.22 *Maximum motor cable lengths and types* is shielded and contains four cores. Typical capacitance for this type of cable is 130 pF/m (i.e. from one core to all others and the shield connected together).

4.9.3 Motor winding voltage

The PWM output voltage can adversely affect the inter-turn insulation in the motor. This is because of the high rate of change of voltage, in conjunction with the impedance of the motor cable and the distributed nature of the motor winding.

For normal operation with AC supplies up to 500 Vac and a standard motor with a good quality insulation system, there is no need for any special precautions. In case of doubt the motor supplier should be consulted. Special precautions are recommended under the following conditions, but only if the motor cable length exceeds 10 m:

- AC supply voltage exceeds 500 V
- DC supply voltage exceeds 670 V, i.e regenerative / AFE supply.
- Operation of 400 V drive with continuous or very frequent sustained braking
- Multiple motors connected to a single drive

For multiple motors, the precautions given in section 4.9.4 *Multiple motors* should be followed.

For the other cases listed, it is recommended that an inverter-rated motor be used taking into account the voltage rating of the inverter. This has a reinforced insulation system intended by the manufacturer for repetitive fast-rising pulsed voltage operation.

Users of 575 V NEMA rated motors should note that the specification for inverter-rated motors given in NEMA MG1 section 31 is sufficient for motoring operation but not where the motor spends significant periods braking. In that case an insulation peak voltage rating of 2.2 kV is recommended.

If it is not practical to use an inverter-rated motor, an output choke (inductor) should be used. The recommended type is a simple iron-cored component with a reactance of about 2 %. The exact value is not critical. This operates in conjunction with the capacitance of the motor cable to increase the rise-time of the motor terminal voltage and prevent excessive electrical stress.

4.9.4 Multiple motors

Open-loop only

If the drive is to control more than one motor, one of the fixed V/F modes should be selected (Pr **05.014** = Fixed or Squared). Make the motor connections as shown in Figure 4-6 and Figure 4-7.

The maximum motor cable lengths specified in section 5.1.22 *Maximum motor cable lengths and types* on page 91 apply to the sum of the total cable lengths from the drive to each motor.

It is recommended that each motor is connected through a protection relay since the drive cannot protect each motor individually. For Δ connection, a sinusoidal filter or an output inductor must be connected as shown in Figure 4-7, even when the cable lengths are less than the maximum permissible. For high DC voltages or when supplied by a regen system, a sinusoidal filter is recommended. For details of filter or inductor sizes refer to the supplier of the drive.

Figure 4-6 Preferred chain connection for multiple motors

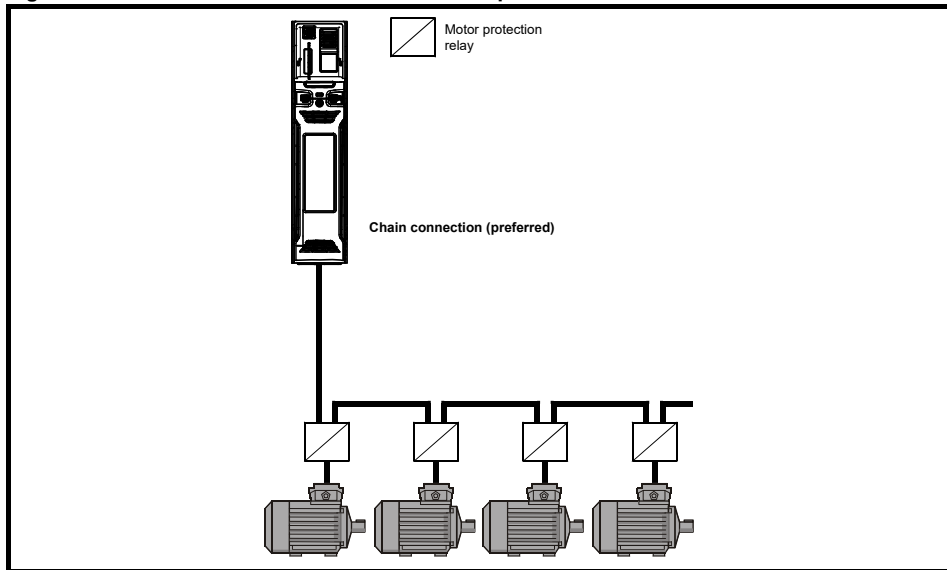
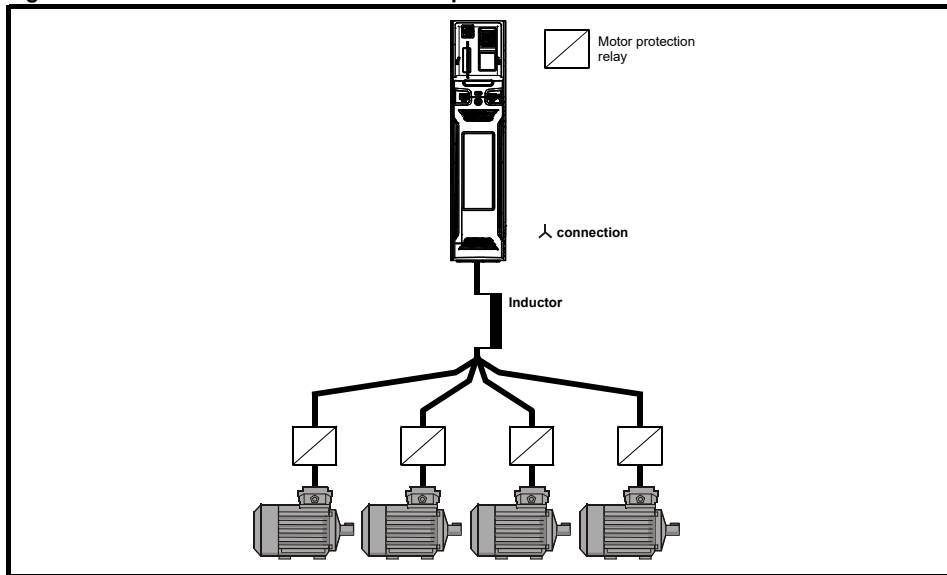

Figure 4-7 Alternative connection for multiple motors



4.9.5 Δ / Δ motor operation

The voltage rating for Δ and Δ connections of the motor should always be checked before attempting to run the motor.

The default setting of the motor rated voltage parameter is the same as the drive rated voltage, i.e.

400 V drive 400 V rated voltage

230 V drive 230 V rated voltage

A typical 3 phase motor would be connected in Δ for 400 V operation or Δ for 230 V operation, however, variations on this are common e.g. Δ 690 V Δ 400 V.

Incorrect connection of the windings will cause severe under or over fluxing of the motor, leading to a very poor output torque or motor saturation and overheating respectively.

4.9.6 Output contactor



If the cable between the drive and the motor is to be interrupted by a contactor or circuit breaker, ensure that the drive is disabled before the contactor or circuit breaker is opened or closed. Severe arcing may occur if this circuit is interrupted with the motor running at high current and low speed.

A contactor is sometimes required to be installed between the drive and motor for safety purposes.

The recommended motor contactor is the AC3 type.

Switching of an output contactor should only occur when the output of the drive is disabled.

Opening or closing of the contactor with the drive enabled will lead to:

1. Ol ac trips (which cannot be reset for 10 seconds)
2. High levels of radio frequency noise emission
3. Increased contactor wear and tear

The Drive Enable terminal when opened provides a Safe Torque Off function. This can in many cases replace output contactors.

For further information see the *Control User Guide*.

4.10 Braking

Braking occurs when the drive is decelerating the motor, or is preventing the motor from gaining speed due to mechanical influences. During braking, energy is returned to the drive from the motor.

When motor braking is applied by the drive, the maximum regenerated power that the drive can absorb is equal to the power dissipation (losses) of the drive.

When the regenerated power is likely to exceed these losses, the DC bus voltage of the drive increases. Under default conditions, the drive brakes the motor under PI control, which extends the deceleration time as necessary in order to prevent the DC bus voltage from rising above a user defined set-point.

If the drive is expected to rapidly decelerate a load, or to hold back an overhauling load, a braking resistor must be installed.

Table 4-5 shows the default DC voltage level at which the drive turns on the braking transistor. However the braking resistor turn on and the turn off voltages are programmable with *Braking IGBT Lower Threshold* (06.073) and *Braking IGBT Upper Threshold* (06.074).

Table 4-5 Default braking transistor turn on voltage

Drive voltage rating	DC bus voltage level
200 V	390 V
400 V	780 V

NOTE When a braking resistor is used, Pr **00.015** should be set to Fast ramp mode.



High temperatures

Braking resistors can reach high temperatures. Locate braking resistors so that damage cannot result. Use cable having insulation capable of withstanding high temperatures.

4.10.1 Heatsink mounted braking resistor

A resistor has been especially designed to be mounted within the heatsink of the drive (size 3 and 4). See section 3.10 *Size 3 and 4 internal braking resistor* for mounting details. The design of the resistor is such that no thermal protection circuit is required, as the device will fail safely under fault conditions. On size 3 and 4 the in built software overload protection is set-up at default for the designated heatsink mounted resistor. The heatsink mounted resistor is not supplied with the drive and can be purchased separately.

Table 4-6 provides the resistor data for each drive rating.

NOTE

The internal / heatsink mounted resistor is suitable for applications with a low level of regen energy only. See Table 4-6.



Braking resistor overload protection parameter settings

Failure to observe the following information may damage the resistor.

The drive software contains an overload protection function for a braking resistor. On size 3 and 4 this function is enabled at default to protect the heatsink mounted resistor. Below are the parameter settings.

Parameter		Size 3		Size 4	
		200 V drive	400 V drive	200 V drive	400 V drive
Braking resistor rated power	Pr 10.030	50 W		100 W	
Braking resistor thermal time constant	Pr 10.031	3.3 s		2.0 s	
Braking resistor resistance	Pr 10.061	75 Ω		38 Ω	

For more information on the braking resistor software overload protection, see Pr **10.030**, Pr **10.031** and Pr **10.061** full descriptions in section 4.10.3 *Braking resistor software overload protection* on page 63.

If the resistor is to be used at more than half of its average power rating, the drive cooling fan must be set to full speed by setting Pr **06.045** to 11.

Table 4-6 Heatsink mounted braking resistor data

Parameter	Size 3	Size 4
Part number	1220-2752	1299-0003
DC resistance at 25 °C	75 Ω	37.5 Ω
Peak instantaneous power over 1 ms at nominal resistance	8 kW	16 kW
Average power over 60 s *	50 W	100 W
Ingress Protection (IP) rating	IP54	
Maximum altitude	2000 m	

* To keep the temperature of the resistor below 70 °C (158 °F) in a 30 °C (86 °F) ambient, the average power rating is 50 W for size 3, 100 W for size 4. The above parameter settings ensure this is the case.

4.10.2 External braking resistor



Overload protection

When an external braking resistor is used, it is essential that an overload protection device is incorporated in the braking resistor circuit; this is described in *Figure 4-8 on page 62*.

When a braking resistor is to be mounted outside the enclosure, ensure that it is mounted in a ventilated metal housing that will perform the following functions:

- Prevent inadvertent contact with the resistor
- Allow adequate ventilation for the resistor

When compliance with EMC emission standards is required, external connection requires the cable to be armored or shielded, since it is not fully contained in a metal enclosure. See section 4.12.5 *Compliance with generic emission standards* on page 71 for further details.

Internal connection does not require the cable to be armored or shielded.

Table 4-7 Minimum resistance values and peak power rating for the braking resistor at 40 °C (104 °F)

Model	Minimum resistance * Ω	Instantaneous power rating kW	Continuous power rating kW
200 V			
03200050	22	7.7	1.5
03200066			1.9
03200080			2.8
03200106			3.6
04200137	18	9.4	4.6
04200185			6.3
400 V			
03400025	74	9.2	1.5
03400031			2.0
03400045			2.8
03400062			4.6
03400078	50	13.6	5.0
03400100			6.6
04400150	37	18.3	9.0
04400172			12.6

* Resistor tolerance: $\pm 10\%$. The minimum resistance specified are for stand-alone drive systems only. If the drive is to be used as part of a common DC bus system different values may be required. See *Braking resistor software overload protection* on page 63.

For high-inertia loads or under continuous braking, the continuous power dissipated in the braking resistor may be as high as the power rating of the drive. The total energy dissipated in the braking resistor is dependent on the amount of energy to be extracted from the load.

The instantaneous power rating refers to the short-term maximum power dissipated during the on intervals of the pulse width modulated braking control cycle. The braking resistor must be able to withstand this dissipation for short intervals (milliseconds). Higher resistance values require proportionately lower instantaneous power ratings.

In most applications, braking occurs only occasionally. This allows the continuous power rating of the braking resistor to be much lower than the power rating of the drive. It is therefore essential that the instantaneous power rating and energy rating of the braking resistor are sufficient for the most extreme braking duty that is likely to be encountered.

Optimization of the braking resistor requires careful consideration of the braking duty.

Select a value of resistance for the braking resistor that is not less than the specified minimum resistance. Larger resistance values may give a cost saving, as well as a safety benefit in the event of a fault in the braking system. Braking capability will then be reduced, which could cause the drive to trip during braking if the value chosen is too large.

The following external brake resistors are available from the supplier of the drive for sizes 3 and 4.

Table 4-8 External brake resistors (40° C ambient) for drive sizes 3 and 4

Part number	Part desc	Ohmic value Pr10.061	Cont power rating Pr10.030	Max inst power rating ton = 1 ms	Pulse power 1/120 s (ED 0.8 %)	Pulse power 5/120 s (ED 4.2 %)	Pulse power 10/120 s (ED 8.3 %)	Pulse power 40/120 s (ED 33 %)	Time constant Pr10.031
1220-2201	DBR, 100 W, 20R, 130 x 68, TS	20 Ω	100 W	2.0 MW	2300 W	1000 W	650 W	250 W	20
1220-2401	DBR, 100 W, 40R, 130 x 68, TS	40 Ω	100 W	1.6 MW	1900 W	900 W	610 W	240 W	16
1220-2801	DBR, 100 W, 80R, 130 x 68, TS	80 Ω	100 W	1.25 MW	1500 W	775 W	570 W	230 W	12.5

The brake resistors can be used in a series or parallel to get the required resistance and power depending on the size of the drive as per Table 4-7. The brake resistor is equipped with a thermal switch. The thermal switch should be integrated in the control circuit by the user.

The resistor combinations shown in Table 4-9 below can be made using one or more brake resistor/s from Table 4-8 above. Pr **10.030**, Pr **10.031** and Pr **10.061** should be set as per information provided in Table 4-8 above. Refer to description of Pr **10.030**, Pr **10.031** and Pr **10.061** in *section 4.10.3 Braking resistor software overload protection* on page 63 for more information.

Table 4-9 Resistor combinations

Model	Heavy duty	150 % Peak power	200 % Peak power	Braking voltage	Resistor Min. value	Resistor combinations
	kW	Ω	Ω		Ω	
03200050	0.7	135	101	390	22	1 x 40 = 40 2 x 80 = 40 (when connected in parallel)
03200066	1.1	92	69			
03200080	1.5	68	51			
03200106	2.2	46	34			
03400025	0.7	540	405	780	74	1 x 80 = 80 2 x 40 = 80 (when connected in series)
03400031	1.1	370	277			
03400045	1.5	271	203			
03400062	2.2	184	138			
03400078	3.0	135	101			
03400100	4.0	101	76			
04200137	3.0	34	25	390	18	1 x 20 = 20 2 x 40 = 20 (when connected in parallel)
04200185	4.0	26	19			
04400150	5.5	74	56	780	37	1 x 40 = 40 2 x 80 = 40 (when connected in parallel)
04400172	7.5	54	40			

Thermal protection circuit for the braking resistor

The thermal protection circuit must disconnect the AC supply from the drive if the resistor becomes overloaded due to a fault. Figure 4-8 shows a typical circuit arrangement.

Figure 4-8 Typical protection circuit for a braking resistor

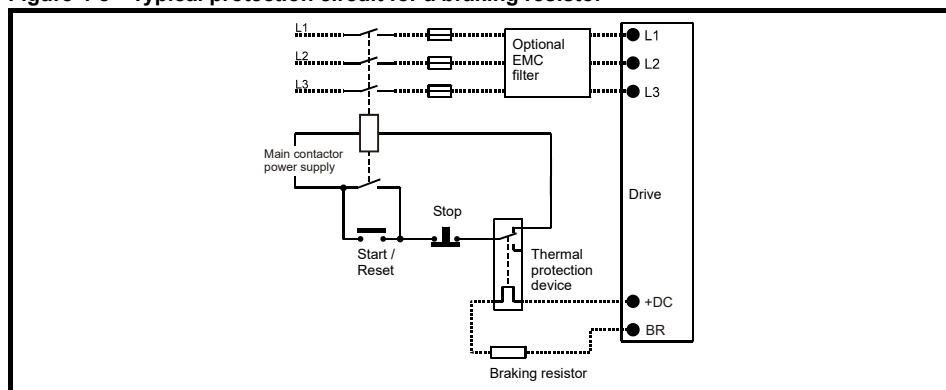

See Figure 4-1 on page 47 and Figure 4-2 on page 48 for the location of the +DC and braking resistor connections.

4.10.3 Braking resistor software overload protection

The drive software contains an overload protection function for a braking resistor. In order to enable and set-up this function, it is necessary to enter three values into the drive:

- *Braking Resistor Rated Power* (10.030)
- *Braking Resistor Thermal Time Constant* (10.031)
- *Braking Resistor Resistance* (10.061)

This data should be obtained from the manufacturer of the braking resistor. The braking resistor thermal time constant can be calculated from resistor data sheet values using the following equation:

$$\text{Pr 10.031} = \frac{\text{Resistor pulse power rating} \times \text{Braking time}}{\text{Resistor continuous power rating}}$$

Pr **10.039** gives an indication of braking resistor temperature based on a simple thermal model. Zero indicates the resistor is close to ambient and 100 % is the maximum temperature the resistor can withstand. A 'Brake Resistor' alarm is given if this parameter is above 75 % and the braking IGBT is active. A Brake R Too Hot trip will occur if Pr **10.039** reaches 100 %, when Pr **10.037** is set to 0 (default value) or 1.

If Pr **10.037** is equal to 2 or 3, a Brake R Too Hot trip will not occur when Pr **10.039** reaches 100 %, but instead the braking IGBT will be disabled until Pr **10.039** falls below 95 %. This option is intended for applications with parallel connected DC buses where there are several braking resistors, each of which cannot withstand full DC bus voltage continuously. With this type of application it is unlikely the braking energy will be shared equally between the resistors because of voltage measurement tolerances within the individual drives. Therefore with Pr **10.037** set to 2 or 3, then as soon as a resistor has reached its maximum temperature the drive will disable the braking IGBT, and another resistor on another drive will take up the braking energy. Once Pr **10.039** has fallen below 95 % the drive will allow the braking IGBT to operate again.

See the *Parameter Reference Guide* for more information on Pr **10.030**, Pr **10.031**, Pr **10.037** and Pr **10.039**.

This software overload protection should be used in addition to an external overload protection device.

4.11 Ground leakage

The ground leakage current depends upon whether the internal EMC filter is installed or not. The drive is supplied with the filter installed. Instructions for removing the internal filter are given in section 4.12.2 *Internal EMC filter* on page 66.

With internal filter installed:

Size 3 to 4: 28 mA* AC at 400 V 50 Hz
30 µA DC with a 600 V DC bus (10 MΩ)

* Proportional to the supply voltage and frequency.

With internal filter removed:

<1 mA



When the internal filter is installed the leakage current is high. In this case a permanent fixed ground connection must be provided, or other suitable measures taken to prevent a safety hazard occurring if the connection is lost.

4.11.1 Use of residual current device (RCD)

There are three common types of ELCB / RCD:

1. AC - detects AC fault currents
2. A - detects AC and pulsating DC fault currents (provided the DC current reaches zero at least once every half cycle)
3. B - detects AC, pulsating DC and smooth DC fault currents
 - Type AC should never be used with drives.
 - Type A can only be used with single phase drives
 - Type B must be used with three phase drives



Only type B ELCB / RCD are suitable for use with 3 phase inverter drives.

If an external EMC filter is used, a delay of at least 50 ms should be incorporated to ensure spurious trips are not seen. The leakage current is likely to exceed the trip level if all of the phases are not energized simultaneously.

4.12 EMC (Electromagnetic compatibility)

The requirements for EMC are divided into three levels in the following three sections:

- section 4.12.3, General requirements for EMC, this is for all applications, to ensure reliable operation of the drive and minimise the risk of disturbing nearby equipment. The immunity standards specified in Chapter 5.1.25 *Electromagnetic compatibility (EMC)* on page 94 will be met, but no specific emission standards are applied.
- section 4.12.4, Requirements for meeting the EMC standard for power drive systems, IEC61800-3 (EN 61800-3:2004).
- section 4.12.5, Requirements for meeting the generic emission standards for the industrial environment, IEC61000-6-4, EN 61000-6-4:2007.

The recommendations of section 4.12.3 will usually be sufficient to avoid causing disturbance to adjacent equipment of industrial quality. If particularly sensitive equipment is to be used nearby, or in a non-industrial environment, then the recommendations of section 4.12.4 or section 4.12.5 should be followed to give reduced radio-frequency emission.

In order to ensure the installation meets the various emission standards described in:

- The EMC data sheet available from the supplier of the drive
- The Declaration of Conformity at the front of this manual
- Chapter 5 *Technical data* on page 77

The correct external EMC filter must be used and all of the guidelines in section 4.12.3 *General requirements for EMC Ground (earth) connections* on page 68 and section 4.12.5 *Compliance with generic emission standards* on page 71 must be followed.

Table 4-10 Drive and EMC filter cross reference

Model	CT part number
200 V	
03200050 to 03200106	4200-3230
04200137 to 04200185	4200-0272
400 V	
03400025 to 03400100	4200-3480
04400150 to 04400172	4200-0252

**High ground leakage current**

When an EMC filter is used, a permanent fixed ground connection must be provided which does not pass through a connector or flexible power cord. This includes the internal EMC filter.

NOTE

The installer of the drive is responsible for ensuring compliance with the EMC regulations that apply in the country in which the drive is to be used.

4.12.1 Grounding hardware

The drive is supplied with a grounding bracket and grounding clamp to facilitate EMC compliance. They provide a convenient method for direct grounding of cable shields without the use of "pig-tails". Cable shields can be bared and clamped¹ to the grounding bracket using metal clips or clamps¹ (not supplied) or cable ties. Note that the shield must in all cases be continued through the clamp to the intended terminal on the drive, in accordance with the connection details for the specific signal.

¹ A suitable clamp is the Phoenix DIN rail mounted SK14 cable clamp (for cables with a maximum outer diameter of 14 mm).

- See Figure 4-9 for details on installing the grounding clamp.
- See Figure 4-10 for details on installing the grounding bracket.

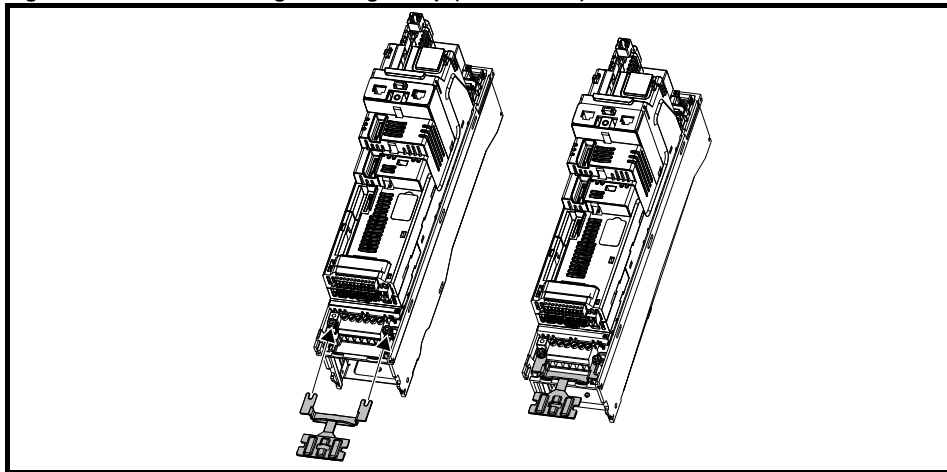
Figure 4-9 Installation of grounding clamp (size 3 and 4)

Loosen the ground connection nuts and slide the grounding clamp in the direction shown. Once in place, the ground connection nuts should be tightened with a maximum torque of 2 N m (1.47 lb ft).

Figure 4-10 Installation of grounding bracket (all sizes -size 3 shown)

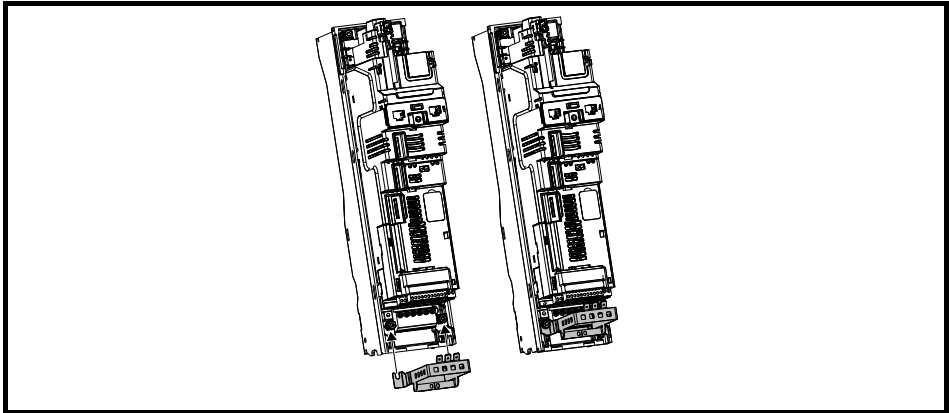

Loosen the ground connection nuts and slide the grounding bracket in the direction shown. Once in place, the ground connection nuts should be tightened with a maximum torque of 2 N m (1.47 lb ft).



On size 3 and 4 the grounding bracket is secured using the power ground terminal of the drive. Ensure that the supply ground connection is secure after installing / removing the grounding bracket. Failure to do so will result in the drive not being grounded.

A faston tab is located on the grounding bracket for the purpose of connecting the drive 0 V to ground should the user require to do so.

4.12.2 Internal EMC filter

It is recommended that the internal EMC filter be kept in place unless there is a specific reason for removing it.



If the drive is used with ungrounded (IT) supplies, the internal EMC filter must be removed unless additional motor ground fault protection is installed. For instructions on removal refer to section 4.12.2. For details of ground fault protection contact the supplier of the drive.

If the drive is used as a motoring drive as part of a regen system, then the internal EMC filter must be removed.

The internal EMC filter reduces radio-frequency emission into the line power supply. Where the motor cable is short, it permits the requirements of EN 61800-3:2004 to be met for the second environment - see section 4.12.4 *Compliance with EN 61800-3:2004 (standard for Power Drive Systems)* on page 70 and section 4.12 *EMC (Electromagnetic compatibility)* on page 64. For longer motor cables the filter continues to provide a useful reduction in emission levels, and when used with any length of shielded motor cable up to the limit for the drive, it is unlikely that nearby industrial equipment will be disturbed. It is recommended that the filter be used in all applications unless the instructions given above require it to be removed, or where the ground leakage current of 28 mA for size 3 is unacceptable. See section 4.12.2 for details of removing and installing the internal EMC filter.

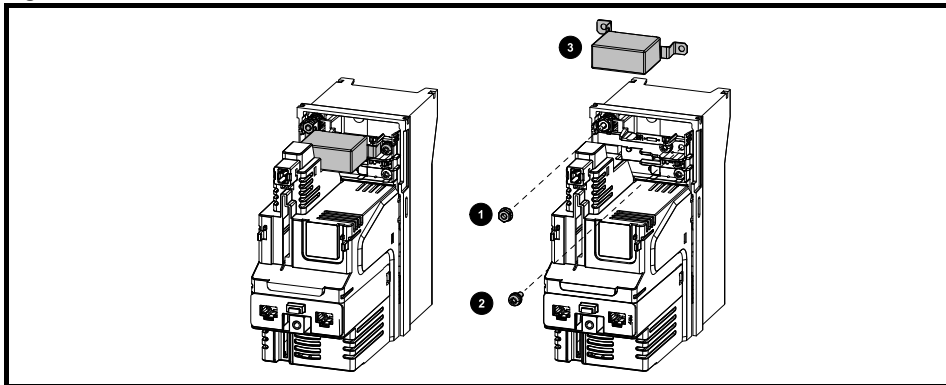

The supply must be disconnected before removing the internal EMC filter.

Figure 4-11 Removal of the size 3 internal EMC filter

Remove the screw and nut (1) and (2) as shown above.

Lift away from the securing points and rotate away from the drive. Ensure the screw and nut are replaced and re-tightened with a maximum torque of 2 N m (1.47 lb ft).

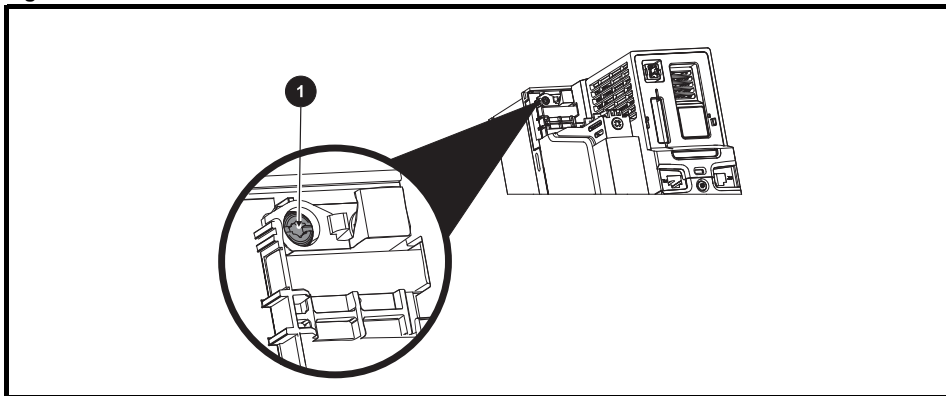
Figure 4-12 Removal of the size 4 internal EMC filter

To electrically disconnect the Internal EMC filter, remove the screw as highlighted above (1).

4.12.3 General requirements for EMC Ground (earth) connections

The grounding arrangements should be in accordance with Figure 4-13, which shows a single drive on a back-plate with or without an additional enclosure.

Figure 4-13 shows how to configure and minimise EMC when using unshielded motor cable. However shielded cable is a better option, in which case it should be installed as shown in section 4.12.5 *Compliance with generic emission standards* on page 71.

Figure 4-13 General EMC enclosure layout showing ground connections

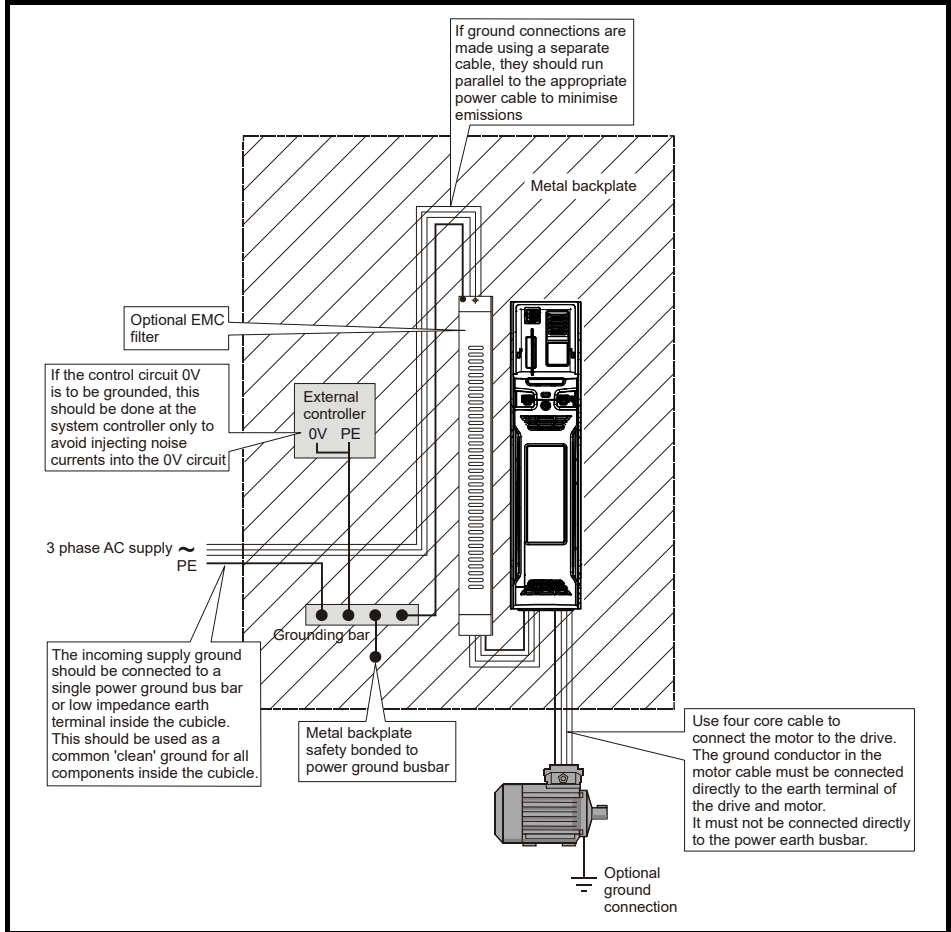

Cable layout

Figure 4-14 indicates the clearances which should be observed around the drive and related 'noisy' power cables by all sensitive control signals / equipment.

Figure 4-14 Drive cable clearances

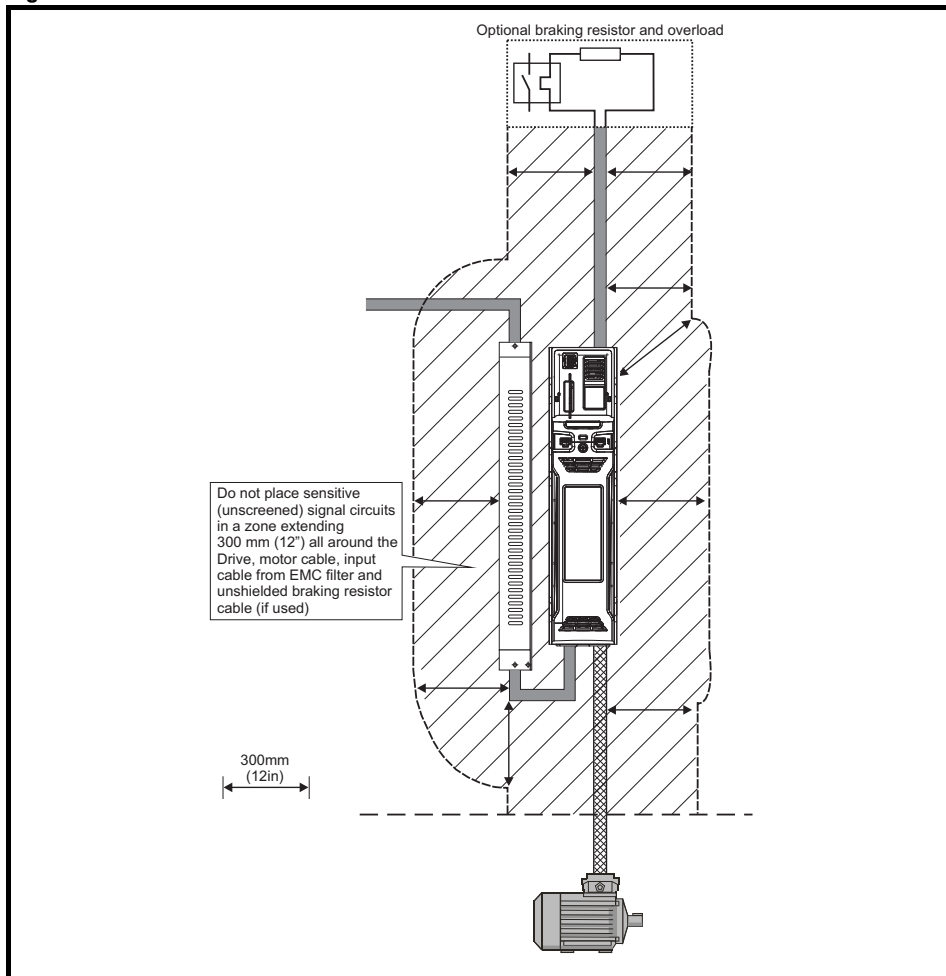

NOTE

Any signal cables which are carried inside the motor cable (i.e. motor thermistor, motor brake) will pick up large pulse currents via the cable capacitance. The shield of these signal cables must be connected to ground close to the motor cable, to avoid this noise current spreading through the control system.

4.12.4 Compliance with EN 61800-3:2004 (standard for Power Drive Systems)

Meeting the requirements of this standard depends on the environment that the drive is intended to operate in, as follows:

Operation in the first environment

Observe the guidelines given in section 4.12.5 *Compliance with generic emission standards* on page 71. An external EMC filter will always be required.



This is a product of the restricted distribution class according to IEC 61800-3

In a residential environment this product may cause radio interference in which case the user may be required to take adequate measures.

Operation in the second environment

In all cases a shielded motor cable must be used, and an EMC filter is required for all drives with a rated input current of less than 100 A.

The drive contains an in-built filter for basic emission control. In some cases feeding the motor cables (U, V and W) once through a ferrite ring can maintain compliance for longer cable lengths.

For longer motor cables, an external filter is required. Where a filter is required, follow the guidelines in section 4.12.5 *Compliance with generic emission standards*.

Where a filter is not required, follow the guidelines given in section 4.12.3 *General requirements for EMC Ground (earth) connections* on page 68.



The second environment typically includes an industrial low-voltage power supply network which does not supply buildings used for residential purposes. Operating the drive in this environment without an external EMC filter may cause interference to nearby electronic equipment whose sensitivity has not been appreciated. The user must take remedial measures if this situation arises. If the consequences of unexpected disturbances are severe, it is recommended that the guidelines in section 4.12.5 *Compliance with generic emission standards* be adhered to.

Refer to section 5.1.25 *Electromagnetic compatibility (EMC)* on page 94 for further information on compliance with EMC standards and definitions of environments.

Detailed instructions and EMC information are given in the *EMC Data Sheet* which is available from the supplier of the drive.

4.12.5 Compliance with generic emission standards

Use the recommended filter and shielded motor cable. Observe the layout rules given in Figure 4-15 and Figure 4-17. Ensure the AC supply and ground cables are at least 100 mm from the power module and motor cable.

Figure 4-15 Supply and ground cable clearance (sizes 3 to 4)

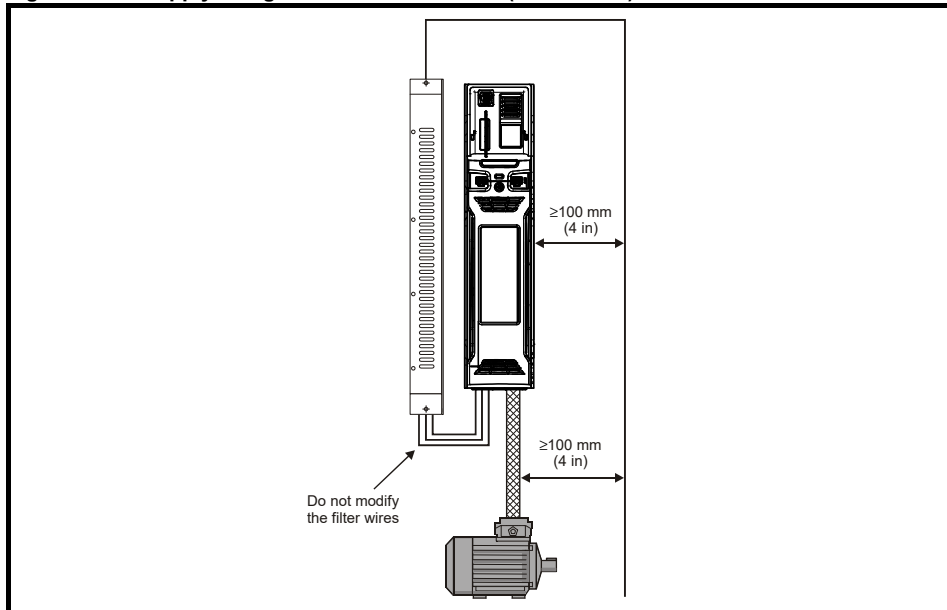
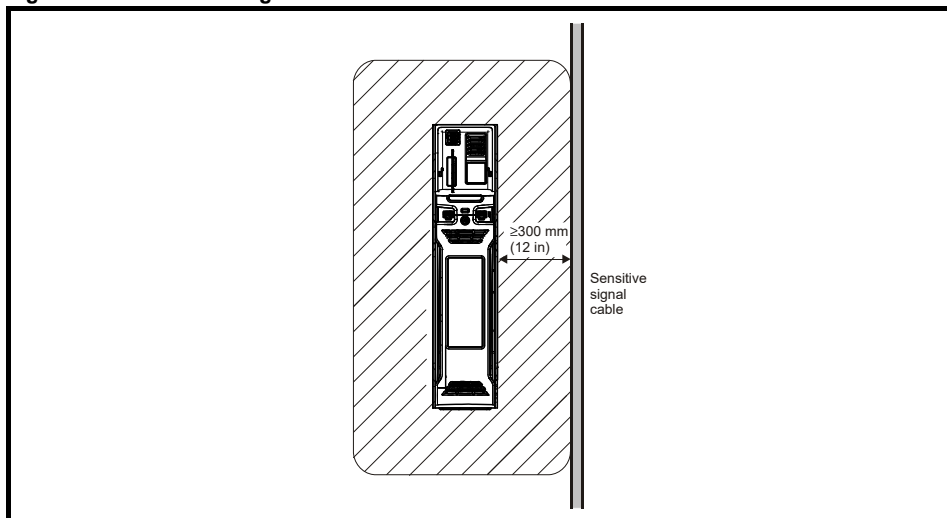
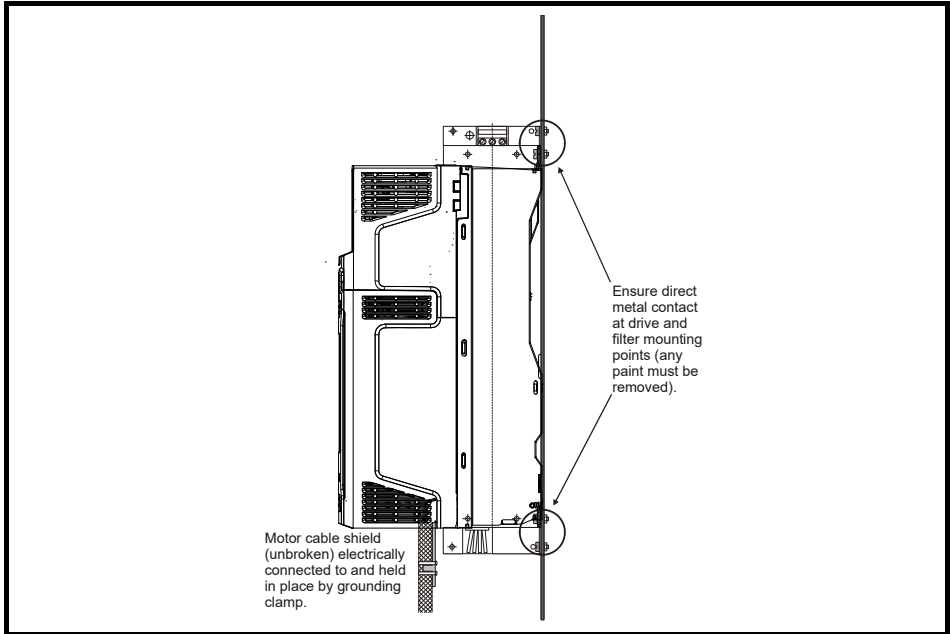

Figure 4-16 Sensitive signal circuit clearance



Avoid placing sensitive signal circuits in a zone 300 mm (12 in) in the area immediately surrounding the power module. Ensure good EMC grounding.

Figure 4-17 Grounding the drive, motor cable shield and filter



Connect the shield of the motor cable to the ground terminal of the motor frame using a link that is as short as possible and not exceeding 50 mm (2 in) long.

A complete 360° termination of the shield to the terminal housing of the motor is beneficial.

From an EMC consideration it is irrelevant whether the motor cable contains an internal (safety) ground core, or if there is a separate external ground conductor, or where grounding is through the shield alone. An internal ground core will carry a high noise current and therefore it must be terminated as close as possible to the shield termination.

Figure 4-18 Grounding the motor cable shield

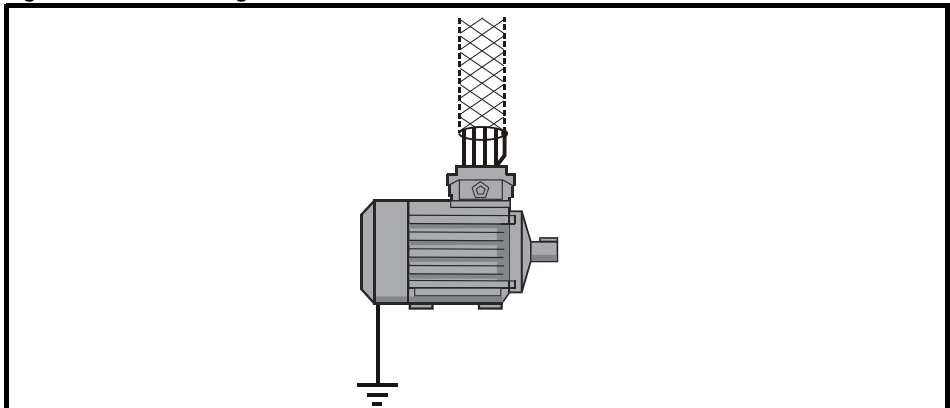

Unshielded wiring to the optional braking resistor(s) may be used provided the wiring runs internally to the enclosure. Ensure a minimum spacing of 300 mm (12 in) from the signal wiring and the AC supply wiring to the external EMC filter. If this condition cannot be met then the wiring must be shielded.

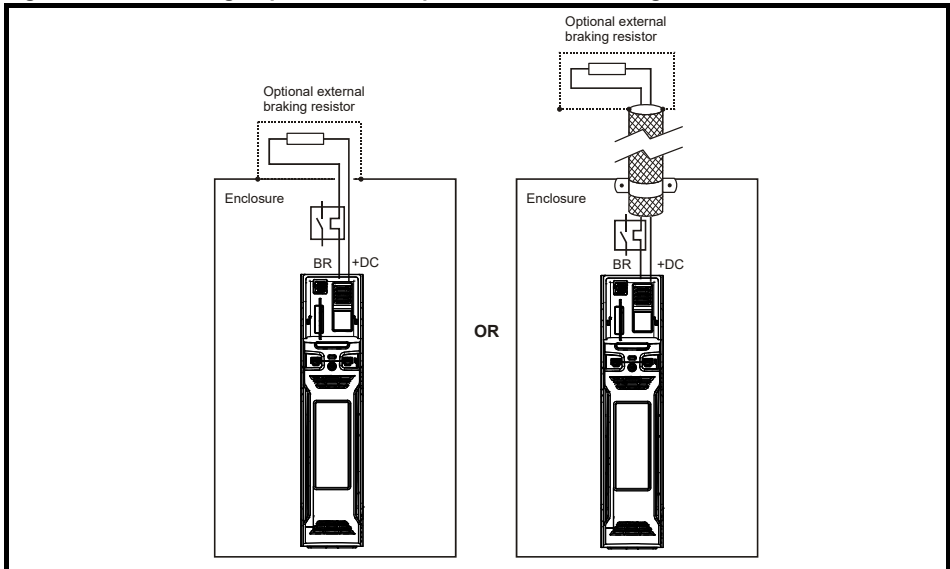
Figure 4-19 Shielding requirements of optional external braking resistor

If the control wiring is to leave the enclosure, it must be shielded and the shield(s) clamped to the drive using the grounding bracket as shown in Figure 4-20. Remove the outer insulating cover of the cable to ensure the shield(s) make direct contact with the bracket, but keep the shield(s) intact until as close as possible to the terminals. Alternatively, wiring may be passed through a ferrite ring, part number 3225-1004.

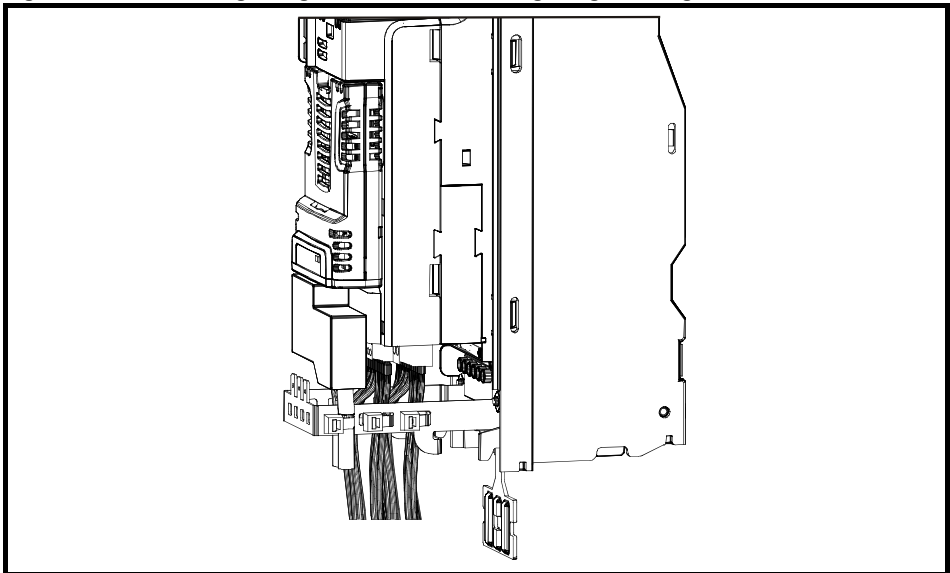
Figure 4-20 Grounding of signal cable shields using the grounding bracket

4.12.6 Variations in the EMC wiring

Interruptions to the motor cable

The motor cable should ideally be a single length of shielded or armored cable having no interruptions. In some situations it may be necessary to interrupt the cable, as in the following examples:

- Connecting the motor cable to a terminal block in the drive enclosure
 - Installing a motor isolator / disconnect switch for safety when work is done on the motor
- In these cases the following guidelines should be followed.

Terminal block in the enclosure

The motor cable shields should be bonded to the back-plate using uninsulated metal cable-clamps which should be positioned as close as possible to the terminal block. Keep the length of power conductors to a minimum and ensure that all sensitive equipment and circuits are at least 0.3 m (12 in) away from the terminal block.

Figure 4-21 Connecting the motor cable to a terminal block in the enclosure

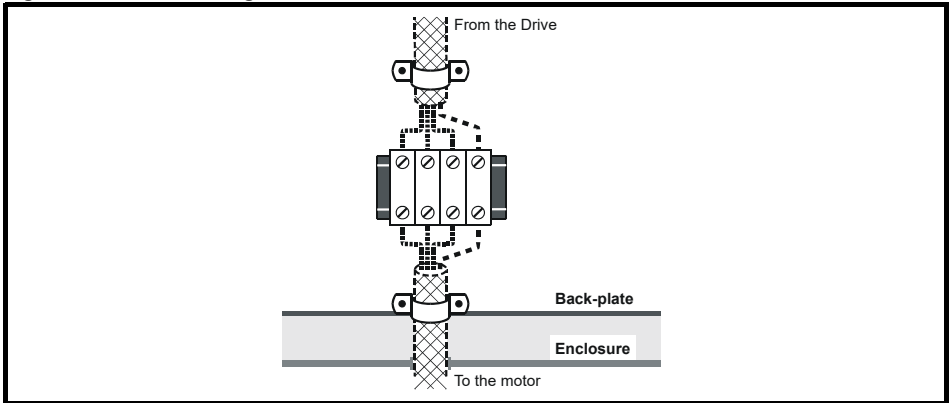

Using a motor isolator / disconnect-switch

The motor cable shields should be connected by a very short conductor having a low inductance. The use of a flat metal coupling-bar is recommended; conventional wire is not suitable.

The shields should be bonded directly to the coupling-bar using uninsulated metal cable-clamps. Keep the length of the exposed power conductors to a minimum and ensure that all sensitive equipment and circuits are at least 0.3 m (12 in) away.

The coupling-bar may be grounded to a known low-impedance ground nearby, for example a large metallic structure which is connected closely to the drive ground.

Figure 4-22 Connecting the motor cable to an isolator / disconnect switch

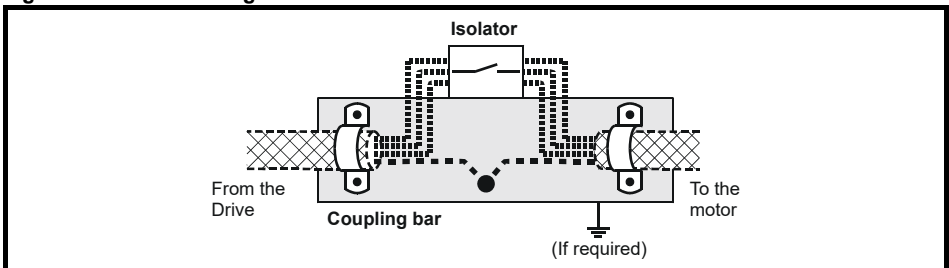

Surge immunity of control circuits - long cables and connections outside a building

The input/output ports for the control circuits are designed for general use within machines and small systems without any special precautions.

These circuits meet the requirements of EN 61000-6-2:2005 (1 kV surge) provided the 0 V connection is not grounded.

In applications where they may be exposed to high-energy voltage surges, some special measures may be required to prevent malfunction or damage. Surges may be caused by lightning or severe power faults in association with grounding arrangements which permit high transient voltages between nominally grounded points. This is a particular risk where the circuits extend outside the protection of a building.

As a general rule, if the circuits are to pass outside the building where the drive is located, or if cable runs within a building exceed 30 m, some additional precautions are advisable. One of the following techniques should be used:

1. Galvanic isolation, i.e. do not connect the control 0 V terminal to ground. Avoid loops in the control wiring, i.e. ensure every control wire is accompanied by its return (0 V) wire.
2. Shielded cable with additional power ground bonding. The cable shield may be connected to ground at both ends, but in addition the ground conductors at both ends of the cable must be bonded together by a power ground cable (equipotential bonding cable) with cross-sectional area of at least 10 mm², or 10 times the area of the signal cable shield, or to suit the electrical safety requirements of the plant. This ensures that fault or surge current passes mainly through the ground cable and not in the signal cable shield. If the building or plant has a well-designed common bonded network this precaution is not necessary.
3. Additional over-voltage suppression - for the analog and digital inputs and outputs, a zener diode network or a commercially available surge suppressor may be connected in parallel with the input circuit as shown in Figure 4-23 and Figure 4-24.

If a digital port experiences a severe surge its protective trip may operate (I/O Overload trip). For continued operation after such an event, the trip can be reset automatically by setting Pr **10.034** to 5.

Figure 4-23 Surge suppression for digital and unipolar inputs and outputs

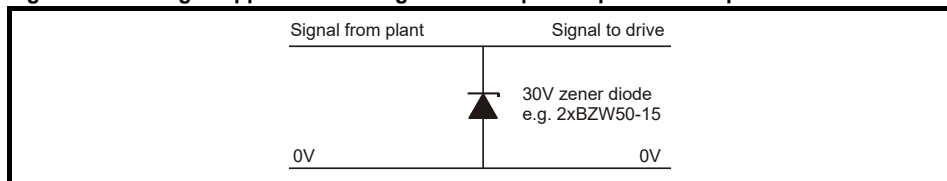
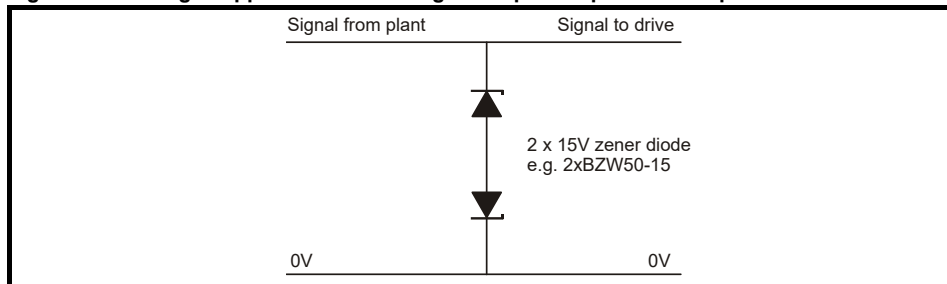

Figure 4-24 Surge suppression for analog and bipolar inputs and outputs



Surge suppression devices are available as rail-mounting modules, e.g. from Phoenix Contact:

Unipolar TT-UKK5-D/24 DC

Bipolar TT-UKK5-D/24 AC

These devices are not suitable for encoder signals or fast digital data networks because the capacitance of the diodes adversely affects the signal. Most encoders have galvanic isolation of the signal circuit from the motor frame, in which case no precautions are required. For data networks, follow the specific recommendations for the particular network.

5 Technical data

5.1 Drive technical data

5.1.1 Power and current ratings

For a full explanation of 'Normal Duty' and 'Heavy Duty' refer to the *Control User Guide*.

The continuous current ratings given are for maximum 40 °C (104 °F), 1000 m altitude and 3 kHz switching frequency. Derating is required for higher switching frequencies, ambient temperature >40 °C (104 °F) and high altitude. For further information, refer to Chapter 5.1.2 *Power and current ratings (Derating for switching frequency and temperature)* on page 78.

Table 5-1 200 V drive ratings (200 V to 240 V ±10 %)

Model	Normal Duty				Heavy Duty				
	Max cont output current	Nominal power at 230 V	Motor power at 230 V	Peak current	Max cont output current	Open loop peak current	RFC peak current	Nominal power at 230 V	Motor power at 230 V
	A	kW	hp	A	A	A	A	kW	hp
03200050	6.6	1.1	1.5	7.2	5	7.5	10	0.75	1
03200066	8	1.5	2	8.8	6.6	9.9	13.2	1.1	1.5
03200080	11	2.2	3	12.1	8	12	16	1.5	2
03200106	12.7	3	3	13.9	10.6	15.9	21.2	2.2	3
04200137	18	4	5	19.8	13.7	20.5	27.4	3	3
04200185	25	5.5	7.5	27.5	18.5	27.7	37	4	5

Table 5-2 400 V drive ratings (380 V to 480 V ±10 %)

Model	Normal Duty				Heavy Duty				
	Max cont output current	Nominal power at 400 V	Motor power at 460 V	Peak current	Max cont output current	Open loop peak current	RFC peak current	Nominal power at 400 V	Motor power at 460 V
	A	kW	hp	A	A	A	A	kW	hp
03400025	3.4	1.1	1.5	3.7	2.5	3.7	5.0	0.75	1.0
03400031	4.5	1.5	2.0	4.9	3.1	4.6	6.2	1.1	1.5
03400045	6.2	2.2	3.0	6.8	4.5	6.7	9.0	1.5	2.0
03400062	7.7	3.0	5.0	8.4	6.2	9.3	12.4	2.2	3.0
03400078	10.4	4.0	5.0	11.4	7.8	11.7	15.6	3.0	5.0
03400100	12.3	5.5	7.5	13.5	10.0	15.0	20.0	4.0	5.0
04400150	18.5	7.5	10.0	20.3	15.0	22.5	30.0	5.5	10.0
04400172	24.0	11.0	15.0	26.4	17.2	25.8	34.4	7.5	10.0

5.1.2 Power and current ratings (Derating for switching frequency and temperature)

Table 5-3 Maximum permissible continuous output current @ 40 °C (104 °F) ambient

Model	Normal Duty								Heavy Duty											
	Nominal rating		Maximum permissible continuous output current (A) for the following switching frequencies								Nominal rating		Maximum permissible continuous output current (A) for the following switching frequencies							
	kW	hp	2 kHz	3 kHz	4 kHz	6 kHz	8 kHz	12 kHz	16 kHz	kW	hp	2 kHz	3 kHz	4 kHz	6 kHz	8 kHz	12 kHz	16 kHz		
200 V																				
03200050	1.1	1.5	6.6						0.75	1.0	5.0									
03200066	1.5	2.0	8.0						1.1	1.5	6.6									
03200080	2.2	3.0	11					10.2	1.5	2.0	8.0						7.5			
03200106	3.0	3.0	12.7				12.1	10.2	2.2	3.0	10.6				8.8	7.5				
04200137	4.0	5.0	18						3.0	3.0	13.7									
04200185	5.5	7.5	25				24	22	4.0	5.0	18.5				17.6	16				
400 V																				
03400025	1.1	1.5	3.4						0.75	1.0	2.5									
03400031	1.5	2.0	4.5						1.1	1.5	3.1									
03400045	2.2	3.0	6.2					5.0	1.5	2.0	4.5						3.7			
03400062	3.0	5.0	7.7				6.2	5.0	2.2	3.0	6.2				5.8	4.5	3.8			
03400078	4.0	5.0	10.4				7.6	5.7	3.0	5.0	7.8				7.6	5.7	4.4			
03400100	5.5	7.5	12.3			10.5	7.6	5.8	4.0	5.0	10		9.2	7.7	5.7	4.4				
04400150	7.5	10	18.5				14.6	11.1	5.5	10	15.0				14.4	11.5	9.4			
04400172	11	15	24		21.8	19.2	14.6	11.2	7.5	10	17.2		16.1	14.4	11.5	9.4				

Table 5-4 Maximum permissible continuous output current @ 40 °C (104 °F) ambient with high IP insert installed

Model	Normal Duty							Heavy Duty						
	Maximum permissible continuous output current (A) for the following switching frequencies							Maximum permissible continuous output current (A) for the following switching frequencies						
	2 kHz	3 kHz	4 kHz	6 kHz	8 kHz	12 kHz	16 kHz	2 kHz	3 kHz	4 kHz	6 kHz	8 kHz	12 kHz	16 kHz
200 V														
03200050	6.6							5.0						
03200066	8.0							6.6						
03200080	11.0						9.7	8.0						6.9
03200106	12.3	11.9	11.1	10.0	9.0	6.4	4.7	10.6		10.4	9.3	7.8	6.8	
04200137	14.5			13.5	12.2	10.5	9.6	13.7		13.5	12.2	10.5	9.6	
04200185	14.5			13.5	12.2	10.5	9.6	14.5		13.5	12.2	10.5	9.6	
400 V														
03400025	3.4						3.3	2.5						
03400031	4.5			4.4	4.1	3.6	3.3	3.1						
03400045	5.1	5.0	4.7	4.4	4.1	3.6	3.3	4.5		4.4	4.1	3.6	3.2	
03400062	7.7		7.4	6.7	6.2	5.7	5.0	6.2			5.6	4.5	3.8	
03400078	8.3			7.6	6.9	6.0	5.2	7.8		7.6	6.9	5.3	4.0	
03400100	8.3			7.6	6.9	6.0	5.2	8.3		7.6	6.9	5.3	4.0	
04400150	8.6					8.4	6.9	8.6				8.4	6.9	
04400172	8.6					8.4	6.9	8.6				8.4	6.9	

Safety information

Product information

Mechanical installation

Electrical installation

Technical data

UL listing information

Table 5-5 Maximum permissible continuous output current @ 50 °C (122 °F)

Model	Normal Duty							Heavy Duty						
	Maximum permissible continuous output current (A) for the following switching frequencies							Maximum permissible continuous output current (A) for the following switching frequencies						
	2 kHz	3 kHz	4 kHz	6 kHz	8 kHz	12 kHz	16 kHz	2 kHz	3 kHz	4 kHz	6 kHz	8 kHz	12 kHz	16 kHz
200 V														
03200050	6.6							5.0						
03200066	8.0							6.6						
03200080	11					10.5	9.1	8.0					7.0	
03200106	12.7	12.6	12.2	11.7	10.5	9.1	10.6			9.6	8.1	7.0		
04200137	18							13.7						
04200185	22.2					20.2	18.5			17.9	16.2	14.8		
400 V														
03400025	3.4							2.5						
03400031	4.5							3.1						
03400045	6.2				5.9	5.4	4.4	4.5			4.2	3.4		
03400062	7.6	7.2	6.9	6.4	5.9	5.4	4.4	7.6		5.8	4.5	3.8		
03400078	10.4			9.3	8.5	6.9	5.1	7.8			7.0	5.1	3.9	
03400100	11.9	11.2	10.5	9.3	8.5	6.9	5.2	10.0		8.3	7.0	5.2	3.9	
04400150	18	17.5	17	16.3	15.8	12.2	9.3	15		14.8	13.2	10.6	8.6	
04400172	18	17.5	17	16.3	15.8	12.2	9.3	17.2	16.8	14.8	13.2	10.6	8.6	

NOTE 55 °C ratings are available on request.

5.1.3 Power dissipation

Table 5-6 Losses @ 40° C (104° F) ambient

Model	Normal Duty									Heavy Duty								
	Nominal rating		Drive losses (W) taking into account any current derating for the given conditions							Nominal rating		Drive losses (W) taking into account any current derating for the given conditions						
	kW	hp	2 kHz	3 kHz	4 kHz	6 kHz	8 kHz	12 kHz	16 kHz	kW	hp	2 kHz	3 kHz	4 kHz	6 kHz	8 kHz	12 kHz	16 kHz
200 V																		
03200050	1.1	1.5	88	93	95	99	104	113	122	0.75	1	74	78	80	84	87	94	101
03200066	1.5	2	95	100	102	107	113	122	133	1.1	1.5	85	89	91	94	99	108	116
03200080	2.2	3	117	123	126	133	139	151	146	1.5	2	92	97	99	105	109	118	111
03200106	3	3	129	136	141	149	158	168	157	2.2	3	109	115	118	126	134	124	116
04200137	4	5	171	180	187	201	216	244	273	3	3	138	145	151	163	174	198	221
04200185	5.5	7.5	227	239	248	266	284	308	314	4	5	176	185	192	207	221	237	241
400 V																		
03400025	1.1	1.5	76	80	84	94	103	123	141	0.75	1	67	71	76	83	92	108	124
03400031	1.5	2	84	88	92	104	115	137	160	1.1	1.5	66	69	73	82	91	107	124
03400045	2.2	3	99	104	112	125	139	167	157	1.5	2	79	83	88	99	109	131	125
03400062	3	5	108	114	122	137	153	149	147	2.2	3	93	98	105	118	123	118	127
03400078	4	5	138	145	158	186	212	201	197	3	5	109	115	125	145	161	166	165
03400100	5	7.5	155	163	179	209	208	201	200	4	5	131	138	151	163	163	166	165
04400150	7.5	10	214	225	244	283	322	325	310	5.5	10	180	189	205	238	262	274	286
04400172	11	15	269	283	307	325	329	325	315	7.5	10	199	210	227	249	262	274	286

Safety information

Product information

Mechanical installation

Electrical installation

Technical data

UL listing information

Table 5-7 Losses @ 40°C (104° F) ambient with high IP insert installed

Model	Normal Duty							Heavy Duty						
	Drive losses (W) taking into consideration any current derating for the given conditions							Drive losses (W) taking into consideration any current derating for the given conditions						
	2 kHz	3 kHz	4 kHz	6 kHz	8 kHz	12 kHz	16 kHz	2 kHz	3 kHz	4 kHz	6 kHz	8 kHz	12 kHz	16 kHz
200 V														
03200050	88	93	95	99	104	113	122	74	78	80	84	87	94	101
03200066	95	100	102	107	113	122	133	85	89	91	94	99	108	116
03200080	117	123	126	133	140	158	157	92	97	99	105	109	118	112
03200106	122	128	124	122	118	98	84	109	115	119	127	122	120	122
04200137	138	145	151	151	146	142	146	145	153	160	161	155	152	155
04200185	204	215	205	194	189	187	199	176	185	192	202	193	191	200
400 V														
03400025	76	80	84	94	103	123	137	67	71	76	83	92	108	124
03400031	84	88	92	102	105	110	134	66	69	73	82	91	107	126
03400045	80	84	85	89	92	109	134	79	83	88	96	100	109	130
03400062	108	114	117	122	135	172	203	93	98	105	118	122	136	155
03400078	112	118	134	155	173	221	267	109	115	126	155	173	195	205
03400100	112	118	134	155	173	221	267	106	112	126	155	173	195	205
04400150	100	105	114	132	153	197	207	103	108	118	136	156	202	214
04400172	96	101	111	131	152	197	207	100	105	114	133	157	202	214

Table 5-8 Losses @ 50° C (122° F) ambient

Model	Normal Duty							Heavy Duty						
	Drive losses (W) taking into account any current derating for the given conditions							Drive losses (W) taking into account any current derating for the given conditions						
	2 kHz	3 kHz	4 kHz	6 kHz	8 kHz	12 kHz	16 kHz	2 kHz	3 kHz	4 kHz	6 kHz	8 kHz	12 kHz	16 kHz
200 V														
03200050	88	93	95	99	104	113	122	74	78	80	84	87	94	101
03200066	95	100	102	107	113	122	133	85	89	91	94	99	108	116
03200080	117	123	126	133	139	144	139	92	97	99	105	109	118	113
03200106	129	136	140	143	147	151	150	109	115	118	126	121	117	116
04200137	171	180	187	201	216	253	297	138	145	151	163	174	198	228
04200185	203	214	223	244	265	312	334	176	185	192	207	217	230	247
400 V														
03400025	76	80	84	118	103	123	141	67	71	76	83	92	108	124
03400031	84	88	92	104	115	137	160	66	69	73	82	91	107	124
03400045	99	104	112	125	132	146	155	79	83	88	99	109	122	121
03400062	106	106	109	114	117	145	155	118	124	132	148	148	140	139
03400078	138	145	158	175	194	225	225	109	115	125	148	160	166	172
03400100	152	152	160	175	194	225	230	131	138	152	158	160	170	172
04400150	213	213	227	262	300	323	325	180	189	205	240	253	276	297
04400172	212	212	227	262	300	318	321	200	211	226	240	253	276	297

Table 5-9 Power losses from the front of the drive when through-panel mounted

Frame size	Power loss
3	≤ 50 W
4	≤ 75 W

5.1.4 Temperature, humidity and cooling method

Ambient temperature operating range:

- 20 °C to 55 °C (- 4 °F to 131 °F).

Output current derating must be applied at ambient temperatures >40 °C (104 °F).

Cooling method: Forced convection

Maximum humidity: 95 % non-condensing at 40 °C (104 °F)

5.1.5 Supply requirements

AC supply voltage:

200 V drive: 200 V to 240 V ± 10 %

400 V drive: 380 V to 480 V ± 10 %

Number of phases: 3

Maximum supply imbalance: 2 % negative phase sequence (equivalent to 3 % voltage imbalance between phases).

Frequency range: 45 to 66 Hz

For UL compliance only, the maximum supply symmetrical fault current must be limited to 100 kA

5.1.6 Line reactors

Input line reactors reduce the risk of damage to the drive resulting from poor phase balance or severe disturbances on the supply network.

Where line reactors are to be used, reactance values of approximately 2 % are recommended.

Higher values may be used if necessary, but may result in a loss of drive output (reduced torque at high speed) because of the voltage drop.

For all drive ratings, 2 % line reactors permit drives to be used with a supply unbalance of up to 3.5 % negative phase sequence (equivalent to 5% voltage imbalance between phases).

Severe disturbances may be caused by the following factors, for example:

- Power factor correction equipment connected close to the drive.
- Large DC drives having no or inadequate line reactors connected to the supply.
- Across the line (DOL) started motor(s) connected to the supply such that when any of these motors are started, the voltage dip exceeds 20 %.

Such disturbances may cause excessive peak currents to flow in the input power circuit of the drive. This may cause nuisance tripping, or in extreme cases, failure of the drive.

Drives of low power rating may also be susceptible to disturbance when connected to supplies with a high rated capacity.

Line reactors are particularly recommended for use with the following drive models when one of the above factors exists, or when the supply capacity exceeds 175 kVA:

03200050, 03200066, 03200080, 03200106,

03400025, 03400031, 03400045, 03400062

Model sizes 03400078 to 04400172 have an internal DC choke so they do not require AC line reactors except for cases of excessive phase unbalance or extreme supply conditions.

When required, each drive must have its own reactor(s). Three individual reactors or a single three-phase reactor should be used.

Reactor current ratings

The current rating of the line reactors should be as follows:

Continuous current rating:

Not less than the continuous input current rating of the drive

Repetitive peak current rating:

Not less than twice the continuous input current rating of the drive

Table 5-10 2 % line reactors

Drive model number	Voltage rating V	Line reactor designation	CT Part number	Line reactor current rating A	Inductance mH	Weight kg	Length mm	Width mm	Height mm
03200050	200	INL2001	4401-0143	13.5	0.79	1.8	156	70	125
03200066	200	INL2001	4401-0143	13.5	0.79	1.8	156	70	125
03200080	200	INL2002	4401-0144	20.6	0.48	2.4	156	80	125
03200106	200	INL2002	4401-0144	20.6	0.48	2.4	156	80	125
04200137	200	INL2002	4401-0144	20.6	0.48	2.4	156	80	125
04200185	200	INL2003	4401-0145	26.8	0.32	2.5	156	80	125
03400025	400	INL4001	4401-0148	6.6	2.94	1.3	80	75	130
03400031	400	INL4001	4401-0148	6.6	2.94	1.3	80	75	130
03400045	400	INL4002	4401-0149	9.1	1.62	1.8	156	70	125
03400062	400	INL4011	4401-0234	13	1.12	2.5	156	80	125
03400078	400	INL4011	4401-0234	13	1.12	2.5	156	80	125
03400100	400	INL4003	4401-0151	15.8	1.05	2.6	156	80	125
04400150	400	INL4004	4401-0152	18.7	0.79	3.5	156	60	145
04400172	400	INL4005	4401-0153	24.3	0.61	4.9	156	75	145

5.1.7 Motor requirements

No. of phases: 3

Maximum voltage:

200 V drive: 240 V

400 V drive: 480 V

5.1.8 Storage

-40 °C (-40 °F) to +55 °C (131 °F) for long term storage, or to +70 °C (158 °F) for short term storage.

Storage time is 2 years.

Electrolytic capacitors in any electronic product have a storage period after which they require reforming or replacing.

The DC bus capacitors have a storage period of 10 years.

The low voltage capacitors on the control supplies typically have a storage period of 2 years and are thus the limiting factor.

Low voltage capacitors cannot be reformed due to their location in the circuit and thus may require replacing if the drive is stored for a period of 2 years or greater without power being applied.

It is therefore recommended that drives are powered up for a minimum of 1 hour after every 2 years of storage. This process allows the drive to be stored for a further 2 years.

5.1.9 Altitude

Altitude range: 0 to 3,000 m (9,900 ft), subject to the following conditions:

1,000 m to 3,000 m (3,300 ft to 9,900 ft) above sea level: de-rate the maximum output current from the specified figure by 1% per 100 m (330 ft) above 1,000 m (3,300 ft)

For example at 3,000 m (9,900 ft) the output current of the drive would have to be de-rated by 20 %.

5.1.10 IP / UL Rating

The drive is rated to IP20 pollution degree 2 (dry, non-conductive contamination only) (NEMA 1). However, it is possible to configure the drive to achieve IP65 rating (sizes 3 to 4) (NEMA 12) at the rear of the heatsink for through-panel mounting (some current derating is required).

The IP rating of a product is a measure of protection against ingress and contact to foreign bodies and water. It is stated as IP XX, where the two digits (XX) indicate the degree of protection provided as shown in Table 5-11.

Table 5-11 IP Rating degrees of protection

First digit		Second digit	
Protection against contact and ingress of foreign bodies		Protection against ingress of water	
0	No protection	0	No protection
1	Protection against large foreign bodies $\phi > 50$ mm (large area contact with the hand)	1	Protection against vertically falling drops of water
2	Protection against medium size foreign bodies $\phi > 12$ mm (finger)	2	Protection against spraywater (up to 15 ° from the vertical)
3	Protection against small foreign bodies $\phi > 2.5$ mm (tools, wires)	3	Protection against spraywater (up to 60 ° from the vertical)
4	Protection against granular foreign bodies $\phi > 1$ mm (tools, wires)	4	Protection against splashwater (from all directions)
5	Protection against dust deposit, complete protection against accidental contact.	5	Protection against heavy splash water (from all directions, at high pressure)
6	Protection against dust ingress, complete protection against accidental contact.	6	Protection against deckwater (e.g. in heavy seas)
7	-	7	Protection against immersion
8	-	8	Protection against submersion

Table 5-12 UL enclosure ratings

UL rating	Description
Type 1	Enclosures are intended for indoor use, primarily to provide a degree of protection against limited amounts of falling dirt.
Type 12	Enclosures are intended for indoor use, primarily to provide a degree of protection against dust, falling dirt and dripping non-corrosive liquids.

5.1.11 Corrosive gasses

Concentrations of corrosive gases must not exceed the levels given in:

- Table A2 of EN 50178:1998
- Class 3C2 of IEC 60721-3-3

This corresponds to the levels typical of urban areas with industrial activities and/or heavy traffic, but not in the immediate neighborhood of industrial sources with chemical emissions.

5.1.12 RoHS compliance

The drive meets EU directive 2011/65/EU for RoHS compliance.

5.1.13 Vibration

Maximum recommended continuous vibration level 0.14 g r.m.s. broad-band 5 to 200 Hz.

NOTE This is the limit for broad-band (random) vibration. Narrow-band vibration at this level which coincides with a structural resonance could result in premature failure.

Bump Test

Testing in each of three mutually perpendicular axes in turn.

Referenced standard: IEC 60068-2-29: Test Eb:

Severity: 18 g, 6 ms, half sine

No. of Bumps: 600 (100 in each direction of each axis)

Random Vibration Test

Testing in each of three mutually perpendicular axes in turn.

Referenced standard: IEC 60068-2-64: Test Fh:

Severity: 1.0 m²/s³ (0.01 g²/Hz) ASD from 5 to 20 Hz

-3 dB/octave from 20 to 200 Hz

Duration: 30 minutes in each of 3 mutually perpendicular axes.

Sinusoidal Vibration Test

Testing in each of three mutually perpendicular axes in turn.

Referenced standard: IEC 60068-2-6: Test Fc:

Frequency range: 5 to 500 Hz

Severity: 3.5 mm peak displacement from 5 to 9 Hz

10 m/s² peak acceleration from 9 to 200 Hz

15 m/s² peak acceleration from 200 to 500 Hz

Sweep rate: 1 octave/minute

Duration: 15 minutes in each of 3 mutually perpendicular axes.

EN 61800-5-1:2007, Section 5.2.6.4. referring to IEC 60068-2-6

Frequency range: 10 to 150 Hz

Amplitude: 10 to 57 Hz at 0.075 mm pk

57 to 150 Hz at 1g p

Sweep rate: 1 octave/minute

Duration: 10 sweep cycles per axis in each of 3 mutually perpendicular axes

5.1.14 Starts per hour

By electronic control: unlimited

By interrupting the AC supply: ≤20 (equally spaced)

5.1.15 Start up time

This is the time taken from the moment of applying power to the drive, to the drive being ready to run the motor:

Sizes 3 and 4 = 2.5 s

For faster start up time a 24V backup supply can be used, see section 4.5 24 Vdc supply on page 53.

5.1.16 Output frequency / speed range

Unidrive Mxxx models:

In all operating modes (Open loop, RFC-A, RFC-S) the maximum output frequency is limited to 550 Hz.

Unidrive HSxx models:

In open loop mode the maximum achievable output frequency is 3,000 Hz.

In RFC-A and RFC-S modes, the maximum achievable output frequency is 1,250Hz.

In RFC-S mode the speed is also limited by the voltage constant (Ke) of the motor unless field weakening operation is enabled. Ke is a specific constant for the servo motor being used. It can normally be found on the motor data sheet in V/k rpm (volts per 1,000 rpm).

It is recommended that a minimum ratio of 12:1 is maintained between the switching frequency and the maximum output frequency to maintain the quality of the output waveform. If this minimum ratio is exceeded, extra motor losses will result due to the increased harmonic content of the output waveform.

5.1.17 Accuracy and resolution

Speed:

The absolute frequency and speed accuracy depends on the accuracy of the crystal used with the drive microprocessor. The accuracy of the crystal is 100 ppm, and so the absolute frequency/speed accuracy is 100 ppm (0.01 %) of the reference, when a preset speed is used. If an analog input is used the absolute accuracy is further limited by the absolute accuracy of the analog input.

The following data applies to the drive only; it does not include the performance of the source of the control signals.

Open loop resolution:

Preset frequency reference: 0.1 Hz

Precision frequency reference: 0.001 Hz

Closed loop resolution

Preset speed reference: 0.1 rpm

Precision speed reference: 0.001 rpm

Analog input 1: 11 bit plus sign

Analog input 2: 11 bit plus sign

Current:

The resolution of the current feedback is 10 bit plus sign.

Accuracy: typical 2 %

worst case 5 %

5.1.18 Acoustic noise

The heatsink fan generates the majority of the sound pressure level at 1 m produced by the drive. The heatsink fan is a variable speed fan. The drive controls the speed at which the fan runs based on the temperature of the heatsink and the drive's thermal model system.

Table 5-13 gives the sound pressure level at 1 m produced by the drive when running at maximum normal and heavy duty current and when the heatsink fan is running at minimum speed.

Table 5-13 Acoustic noise data

Size	Max ND operation dBA	Max HD operation* dBA	Min fan speed dBA
3	62.8	50.9	42.9
4	62.6	56.9	45.8

*At 40 °C ambient and 3 kHz switching frequency.

5.1.19 Overall dimensions

H	Height including surface mounting brackets
W	Width
D	Projection forward of panel when surface mounted
F	Projection forward of panel when through-panel mounted
R	Projection rear of panel when through-panel mounted

Table 5-14 Overall drive dimensions

Size	Dimension				
	H	W	D	F	R
3	382 mm (15.04 in)	83 mm (3.27 in)	200 mm (7.87 in)	134 mm (5.28 in)	67 mm (2.64 in)
4	391 mm (15.39 in)	124 mm (4.88 in)			67 mm (2.64 in)

5.1.20 Weights

Table 5-15 Overall drive weights

Size	Model	kg	lb
3	034300078, 034300100	4.5	9.9
	All other variants	4.0	8.8
4	All variants	6.5	14.30

5.1.21 Input current, fuse and cable size ratings

The input current is affected by the supply voltage and impedance.

Typical input current

The values of typical input current are given to aid calculations for power flow and power loss. The values of typical input current are stated for a balanced supply.

Maximum continuous input current

The values of maximum continuous input current are given to aid the selection of cables and fuses. These values are stated for the worst case condition with the unusual combination of stiff supply with bad balance. The value stated for the maximum continuous input current would only be seen in one of the input phases. The current in the other two phases would be significantly lower.

The values of maximum input current are stated for a supply with a 2 % negative phase-sequence imbalance and rated at the maximum supply fault current given in Table 5-16.

Table 5-16 Supply fault current used to calculate maximum input currents

Model	Symmetrical fault level (kA)
All	100



Fuses

The AC supply to the drive must be installed with suitable protection against overload and short-circuits. Table 5-17 and Table 5-18 shows the recommended fuse ratings. Failure to observe this requirement will cause risk of fire.

Table 5-17 AC Input current and fuse ratings (200 V)

Model	Typical input current A	Maximum continuous input current A	Maximum overload input current A	Fuse rating					
				IEC			UL / USA		
				Nominal A	Max A	Class	Nominal A	Max A	Class
03200050	8.2	10.4	15.8	16	25	gG	20	25	CC, J or T*
03200066	9.9	12.6	20.9	20					
03200080	14	17	25	25					
03200106	16	20	34	25					
04200137	17	20	30	25	25	gG	25	25	CC, J or T*
04200185	23	28	41	32	32		30	30	

* These fuses are fast acting.

Table 5-18 AC Input current and fuse ratings (400 V)

Model	Typical input current A	Maximum continuous input current A	Maximum overload input current A	Fuse rating					
				IEC			UL / USA		
				Nominal A	Max A	Class	Nominal A	Max A	Class
03400025	5	5	7	10	10	gG	10	10	CC, J or T*
03400031	6	7	9						
03400045	8	9	13						
03400062	11	13	21						
03400078	12	13	20	20	20	gG	20	20	CC, J or T*
03400100	14	16	25						
04400150	17	19	30	25	25	gG	25	25	CC, J or T*
04400172	22	24	35	32	32		30	30	

* These fuses are fast acting.

NOTE Ensure cables used suit local wiring regulations.



The nominal cable sizes below are only a guide. The mounting and grouping of cables affects their current-carrying capacity, in some cases smaller cables may be acceptable but in other cases a larger cable is required to avoid excessive temperature or voltage drop. Refer to local wiring regulations for the correct size of cables.

Table 5-19 Cable ratings (200 V)

Model	Cable size (IEC) mm ²						Cable size (UL) AWG			
	Input			Output			Input		Output	
	Nominal	Max	Install method	Nominal	Max	Install method	Nominal	Max	Nominal	Max
03200050	1.5	4	B2	1.5	4	B2	14	10	14	10
03200066				4			12			
03200080	4	8	B2	4	8	B2	12	8	12	8
03200106				6			10			
04200137	6	8	B2	6	8	B2	10	8	10	8
04200185	8			8			8			

Table 5-20 Cable ratings (400 V)

Model	Cable size (IEC) mm ²						Cable size (UL) AWG			
	Input			Output			Input		Output	
	Nominal	Max	Install method	Nominal	Max	Install method	Nominal	Max	Nominal	Max
03400025	1.5	4	B2	1.5	4	B2	18	10	18	10
03400031							16		16	
03400045							14		14	
03400062									12	
03400078	2.5	6	B2	2.5	6	B2	10	8	10	8
03400100							8		8	

5.1.22 Maximum motor cable lengths and types

Since capacitance in the motor cable causes loading on the output of the drive, ensure the cable length does not exceed the values given in Table 5-21 and Table 5-22.

Use 105 °C (221 °F) (UL 60/75 °C temp rise) PVC-insulated cable with copper conductors having a suitable voltage rating, for the following power connections:

- AC supply to external EMC filter (when used)
- AC supply (or external EMC filter) to drive
- Drive to motor
- Drive to braking resistor

Table 5-21 Maximum motor cable lengths (200 V drives)

200 V Nominal AC supply voltage							
Model	Maximum permissible motor cable length for each of the following switching frequencies						
	2 kHz	3 kHz	4 kHz	6 kHz	8 kHz	12 kHz	16 kHz
03200050	65 m (210 ft)					50 m (165 ft)	37 m (120 ft)
03200066	100 m (330 ft)				75 m (245 ft)		
03200080	130 m (425 ft)			100 m (330 ft)			
03200106	200 m (660 ft)		150 m (490 ft)				
04200137	200 m (660 ft)		150 m (490 ft)	100 m (330 ft)	75 m (245 ft)	50 m (165 ft)	37 m (120 ft)
04200185							

Table 5-22 Maximum motor cable lengths (400 V drives)

400 V Nominal AC supply voltage							
Model	Maximum permissible motor cable length for each of the following switching frequencies						
	2 kHz	3 kHz	4 kHz	6 kHz	8 kHz	12 kHz	16 kHz
03400025	65 m (210 ft)					50 m (165 ft)	37 m (120 ft)
03400031	100 m (330 ft)				75 m (245 ft)		
03400045	130 m (425 ft)			100 m (330 ft)			
03400062	200 m (660 ft)		150 m (490 ft)				
03400078							
03400100							
04400150	200 m (660 ft)		150 m (490 ft)	100 m (330 ft)	75 m (245 ft)	50 m (165 ft)	37 m (120 ft)
04400172	200 m (660 ft)		150 m (490 ft)	100 m (330 ft)	75 m (245 ft)	50 m (165 ft)	37 m (120 ft)

- Cable lengths in excess of the specified values may be used only when special techniques are adopted; refer to the supplier of the drive.
- The default switching frequency is 3 kHz for Open-loop and RFC-A and 6 kHz for RFC-S mode. The maximum cable length is reduced from that shown in Table 5-21 and Table 5-22 if high capacitance or reduced diameter motor cables are used, refer to Chapter 4.9.2 *High-capacitance / reduced diameter cables* on page 55.

5.1.23 Braking resistor values

Table 5-23 Braking resistor resistance and power rating at 40 °C (104 °F) (200 V)

Model	Minimum resistance *	Instantaneous power rating	Continuous power rating
	Ω	kW	kW
03200050	22	7.7	1.7
03200066			2.2
03200080			3.1
03200106			4.2
04200137	18	9.4	5.1
04200185			7.4

Table 5-24 Braking resistor resistance and power rating at 40 °C (104 °F) (400 V)

Model	Minimum resistance *	Instantaneous power rating	Continuous power rating
	Ω	kW	kW
03400025	74	9.2	1.7
03400031			2.3
03400045			3.1
03400062			5.1
03400078	50	13.6	6.4
03400100			7.3
04400150	37	18.3	12.5
04400172			13.9

* Resistor tolerance: $\pm 10\%$. The minimum resistance specified are for stand-alone drive systems only. If the drive is to be used as part of a common DC bus system different values may be required. See *Braking resistor software overload protection* on page 63.

5.1.24 Torque settings and maximum cable size

Table 5-25 Drive control and relay terminal data

Model	Connection type	Torque setting
All	Plug-in terminal block	0.5 N m (0.4 lb ft)

Table 5-26 Drive power terminal data

Frame size	AC and motor terminals		DC and braking		Ground terminal	
	Recommended	Maximum	Recommended	Maximum	Recommended	Maximum
3 and 4	Plug-in terminal block		T20 Torx (M4)		T20 Torx (M4) / M4 Nut (7 mm AF)	
	0.7 N m (0.5 lb ft)	0.8 N m (0.6 lb ft)	2.0 N m (1.4 lb ft)	2.5 N m (1.8 lb ft)	2.0 N m (1.4 lb ft)	2.5 N m (1.8 lb ft)

Table 5-27 Plug-in terminal block maximum cable sizes

Frame size	Terminal block description	Max cable size
All	11 way control connectors	1.5 mm ² (16 AWG)
	2 way relay connector	2.5 mm ² (12 AWG)
3	6 way AC power connector	6 mm ² (10 AWG)
4		

Table 5-28 External EMC filter terminal data

CT part number	Power connections		Ground connections	
	Max cable size	Max torque	Ground stud size	Max torque
4200-0252	16 mm ² (6 AWG)	1.8 N m (1.4 lb ft)	M6	4.8 N m (2.8 lb ft)
4200-0272				
4200-3230	4 mm ² (12 AWG)	0.8 N m (0.59 lb ft)	M5	3.0 N m (2.2 lb ft)
4200-3480				

5.1.25 Electromagnetic compatibility (EMC)

This is a summary of the EMC performance of the drive. For full details, refer to the *EMC Data Sheet* which can be obtained from the supplier of the drive.

Table 5-29 Immunity compliance

Standard	Type of immunity	Test specification	Application	Level
IEC61000-4-2 EN61000-4-2	Electrostatic discharge	6 kV contact discharge 8 kV air discharge	Module enclosure	Level 3 (industrial)
IEC61000-4-3 EN61000-4-3	Radio frequency radiated field	10 V/m prior to modulation 80 - 1000 MHz 80 % AM (1 kHz) modulation	Module enclosure	Level 3 (industrial)
IEC61000-4-4 EN61000-4-4	Fast transient burst	5/50 ns 2 kV transient at 5 kHz repetition frequency via coupling clamp	Control lines	Level 4 (industrial harsh)
		5/50 ns 2 kV transient at 5 kHz repetition frequency by direct injection	Power lines	Level 3 (industrial)
IEC61000-4-5 EN61000-4-5	Surges	Common mode 4 kV 1.2/50 μ s waveshape	AC supply lines: line to ground	Level 4
		Differential mode 2 kV 1.2/50 μ s waveshape	AC supply lines: line to line	Level 3
		Lines to ground	Signal ports to ground ¹	Level 2
IEC61000-4-6 EN61000-4-6	Conducted radio frequency	10V prior to modulation 0.15 - 80 MHz 80 % AM (1 kHz) modulation	Control and power lines	Level 3 (industrial)
IEC61000-4-11 EN61000-4-11	Voltage dips and interruptions	-30 % 10 ms +60 % 100 ms -60 % 1 s <-95 % 5 s	AC power ports	
IEC61000-6-1 EN61000-6-1:2007	Generic immunity standard for the residential, commercial and light - industrial environment			Complies
IEC61000-6-2 EN61000-6-2:2005	Generic immunity standard for the industrial environment			Complies
IEC61800-3 EN61800-3:2004	Product standard for adjustable speed power drive systems (immunity requirements)		Meets immunity requirements for first and second environments	

¹ See section 4.12.6 *Variations in the EMC wiring* on page 74 for possible requirements regarding grounding and external surge protection of the control ports.

Emission

The drive contains an in-built filter for basic emission control. An additional optional external filter provides further reduction of emission. The requirements of the following standards are met, depending on the motor cable length and switching frequency.

Table 5-30 Size 3 emission compliance (200 V drives)

Motor cable length (m)	Switching Frequency (kHz)						
	2	3	4	6	8	12	16
Using internal filter:							
0 – 2	C3			C4			
Using internal filter and ferrite ring (2 turns):							
0 – 10	C3			C4			
10-20	C3			C4			
Using external filter:							
0 – 20	R (C1)	R (C1)	I (C2)	I (C2)	I (C2)	I (C2)	I (C2)
20 – 100	I (C2)	I (C2)	C3	C3	C3	C3	C3

Table 5-31 Size 3 emission compliance (400 V drives)

Motor cable length (m)	Switching Frequency (kHz)						
	2	3	4	6	8	12	16
Using internal filter:							
0 – 5	C3			C4			
Using internal filter and ferrite ring (2 turns):							
0 – 10	C3			C4			
Using external filter:							
0 – 20	R (C1)	R (C1)	I (C2)	I (C2)	I (C2)	I (C2)	I (C2)
20 – 100	I (C2)	I (C2)	C3	C3	C3	C3	C3

Table 5-32 Size 4 emission compliance (200 V drives)

Motor cable length (m)	Switching Frequency (kHz)						
	2	3	4	6	8	12	16
Using internal filter:							
0 – 2	C3			C4			
Using internal filter and ferrite ring (2 turns):							
0 – 4	C3			C4			
Using external filter:							
0 – 20	R (C1)	R (C1)	I (C2)	I (C2)	I (C2)	I (C2)	I (C2)
20 – 100	I (C2)	I (C2)	C3	C3	C3	C3	C3

Table 5-33 Size 4 emission compliance (400 V drives)

Motor cable length (m)	Switching Frequency (kHz)						
	2	3	4	6	8	12	16
Using internal filter:							
0 – 4	C3			C4			
Using internal filter and ferrite ring (2 turns):							
0 – 10	C3			C4			
Using external filter:							
0 – 20	R (C1)	R (C1)	I (C2)	I (C2)	I (C2)	I (C2)	I (C2)
20 – 100	I (C2)	I (C2)	C3	C3	C3	C3	C3

Key (shown in decreasing order of permitted emission level):

E2R EN 61800-3:2004 second environment, restricted distribution (Additional measures may be required to prevent interference)

E2U EN 61800-3:2004 second environment, unrestricted distribution

I Industrial generic standard EN 61000-6-4:2007
 EN 61800-3:2004 first environment restricted distribution (The following caution is required by EN 61800-3:2004)



This is a product of the restricted distribution class according to IEC 61800-3. In a residential environment this product may cause radio interference in which case the user may be required to take adequate measures.

R Residential generic standard EN 61000-6-3:2007
 EN 61800-3:2004 first environment unrestricted distribution

EN 61800-3:2004 defines the following:

- The first environment is one that includes residential premises. It also includes establishments directly connected without intermediate transformers to a low-voltage power supply network which supplies buildings used for residential purposes.
- The second environment is one that includes all establishments other than those directly connected to a low-voltage power supply network which supplies buildings used for residential purposes.
- Restricted distribution is defined as a mode of sales distribution in which the manufacturer restricts the supply of equipment to suppliers, customers or users who separately or jointly have technical competence in the EMC requirements of the application of drives.

IEC 61800-3:2004 and EN 61800-3:2004

The 2004 revision of the standard uses different terminology to align the requirements of the standard better with the EC EMC Directive.

Power drive systems are categorized C1 to C4:

Category	Definition	Corresponding code used above
C1	Intended for use in the first or second environments	R
C2	Not a plug-in or movable device, and intended for use in the first environment only when installed by a professional, or in the second environment	I
C3	Intended for use in the second environment, not the first environment	E2U
C4	Intended for use in the second environment in a system rated at over 400A, or in a complex system.	E2R

Note that category 4 is more restrictive than E2R, since the rated current of the PDS must exceed 400 A or the supply voltage exceed 1000 V, for the complete PDS.

5.2 Optional external EMC filters

Table 5-34 EMC filter cross reference

Model	CT part number
200 V	
03200050 to 03200106	4200-3230
04200137 to 04200185	4200-0272
400 V	
03400025 to 03400100	4200-3480
04400150 to 04400172	4200-0252

5.2.1 EMC filter ratings

Table 5-35 Optional external EMC filter details

Part number	Maximum continuous current		Voltage rating		IP rating	Power dissipation at rated current		Ground leakage		Discharge resistors
	@ 40 °C (104 °F)	@ 50 °C (122 °F)	IEC	UL		@ 40 °C (104 °F)	@ 50 °C (122 °F)	Balanced supply phase-to-phase and phase-to-ground	Worst case	
	A	A	V	V		W	W	mA	mA	
4200-3230	20	18.5	250	300	20	20	17	2.4	60	1.68
4200-0272	27	24.8	250	300		33	28	6.8	137	
4200-3480	16	15	528	600		13	11	10.7	151	
4200-0252	25	23	528	600		28	24	11.1	182	

5.2.2 Overall EMC filter dimensions

Table 5-36 Optional external EMC filter dimensions

Part number	Dimension (mm)						Weight	
	H		W		D			
	mm	inch	mm	inch	mm	inch	kg	lb
4200-3230	426	16.77	83	3.27	41	1.61	1.9	4.20
4200-0272	437	17.20	123	4.84	60	2.36	4.0	8.82
4200-3480	426	16.77	83	3.27	41	1.61	2.0	4.40
4200-0252	437	17.20	123	4.84	60	2.36	4.1	9.04

5.2.3 EMC filter torque settings

Table 5-37 Optional external EMC Filter terminal data

Part number	Power connections		Ground connections	
	Max cable size	Max torque	Ground stud size	Max torque
4200-0252	16 mm ² (6 AWG)	1.8 N m (1.4 lb ft)	M6	5.0 N m (3.7 lb ft)
4200-0272				
4200-3230	4 mm ² (12 AWG)	0.8 N m (0.59 lb ft)	M5	2.5 N m (1.8 lb ft)
4200-3480				

6 UL Information

6.1 UL file reference

The products covered by this manual are UL Listed to both Canadian and US requirements. The UL file reference is: NMMS/7.E171230.

Products that incorporate the Safe Torque Off (STO) function are Certified for Functional Safety. The UL file reference is: FSPC.E171230.

6.2 Option modules, kits and accessories

Option Modules, Control Pods, Installation Kits and other accessories for use with these drives are UL Listed.

6.3 Enclosure ratings

6.3.1 Open Type

With the exception of free-standing cubicle drives, all models are Open Type as supplied. The drive housing is not rated as a fire enclosure. A separate fire enclosure must be provided.

6.3.2 Type 1

When fitted with a conduit box the drives meet the requirements for UL Type 1. Type 1 enclosures are intended for indoor use, primarily to provide a degree of protection against limited amounts of falling dirt.

6.3.3 Plenum rating with conduit box

When fitted with a conduit box, the drives comply with the requirements in the Standard for Fire Test for Heat and Visible Smoke Release for Discrete Products and Their Accessories Installed in Air-Handling Spaces, UL 2043.

6.3.4 Through-hole mounting

The drives meet the requirements for UL Type 12 when installed inside a Type 12 enclosure with the heatsink through-hole mounted using the sealing kit and the high-IP insert (where provided).

When through-hole mounted, the drives are suitable for use in surrounding air temperatures up to 40 °C.

When the drive is through-panel mounted, the main terminal cover(s) must be removed in order to provide access to the mounting holes. Once the drive has been mounted, the terminal cover(s) can be replaced.

Tightening torques are specified in the Mechanical Installation section of this user guide.

6.3.5 Remote Keypads

Remote keypads are UL Type 12 when installed with the sealing washer and fixing kit provided.

6.4 Mounting

Drives may be surface, through-panel or tile mounted using the appropriate brackets. Drives may be mounted singly or side by side with suitable space between them (bookcase mounting).

6.5 Environment

Drives must be installed in a Pollution Degree 2 environment or better (dry, non-conductive pollution only).

The drives have been evaluated for use at ambient temperatures up to 40 °C. The drives have additionally been evaluated for 50 °C and 55 °C ambient air temperatures with a derated output.

6.6 Electrical Installation

6.6.1 Overvoltage category

Drives have been evaluated for OVC III

6.6.2 Supply

When protected by the specified, Listed branch fuses, the drives are suitable for use on a circuit capable of delivering not more than 100,000 RMS symmetrical amperes.

6.6.3 Terminal Torque

Terminals must be tightened to the rated torque as specified in the Installation Instructions.

6.6.4 Wiring Terminals

Drives must be installed using cables rated for 75 °C operation, copper wire only.

Where possible, UL Listed closed-loop connectors sized according to the field wiring shall be used for all field power wiring connections.

6.6.5 Ground connection instructions

UL Listed closed-loop connectors sized according to the field wiring shall be used for grounding connections.

6.6.6 Opening of branch circuit

Opening of the branch-circuit protective device may be an indication that a fault has been interrupted. To reduce the risk of fire or electric shock, the equipment should be examined and replaced if damaged. If burnout of the current element of an overload relay occurs, the complete overload relay must be replaced.

6.6.7 Solid state short circuit protection

All drives incorporate solid state short circuit protection. However, this does not provide branch circuit protection.

6.6.8 Branch circuit protection

Branch circuit protection must be provided in accordance with the National Electrical Code (NEC), The Canadian Electrical Code, and any additional local codes. The fuse and circuit breaker types are specified in the Electrical Installation section of this manual

6.6.9 Dynamic braking

The drives have not been evaluated for dynamic braking.

6.6.10 Regenerative operation

Drives can be configured as an AC Regenerative Unit (also known as a Regen drive). Regen operation allows bi-directional power flow to and from the AC supply. The AC supply voltage must not exceed 600 Vac.

In these systems the inverter output is connected to the AC supply via a reactor and switching frequency filter. The drives are required to be protected by listed branch fuses as specified in the installation instructions. For grid feed applications, further evaluation may be required to other standards, such as, but not limited to UL1741, CSA C22.2 No. 107.1-01, IEEE 1547 etc.

6.7 Motor overload protection and thermal memory retention

All drives incorporate internal overload protection for the motor load that does not require the use of an external or remote overload protection device.

The protection level is adjustable and the method of adjustment is provided in the relevant Control User Guide. Maximum current overload is dependent on the values entered into the current limit parameters (motoring current limit, regenerative current limit and symmetrical current limit entered as percentage) and the motor rated current parameter (entered in amperes).

The duration of the overload is dependent on motor thermal time constant. The maximum programmable time constant depends on the drive model.

The method of adjustment of the overload protection is provided.

The drives are provided with user terminals that can be connected to a motor thermistor to protect the motor from high temperature, in the event of a motor cooling fan failure.

6.8 External Class 2 supply

The external power supply used to power the 24 V control circuit shall be marked: "UL Class 2". The power supply voltage shall not exceed 24 Vdc.

6.9 Modular Drive Systems

Drives with DC+ and DC- supply connections, rated 230 V or 480 V have been investigated for use in Modular Drive Systems as inverters when supplied by the converter sections from the Unidrive-M range. In these applications the inverters are required to be additionally protected by supplemental fuses.

Alternatively, the inverters may be supplied by converter models: Mentor MP25A, 45A, 75A, 105A, 155A or 210A.

Contact the supplier of the drive for more information.



0478-0254-07