

Unidrive M200 to M702, F300, H300, E200 & E300 Size 9 & 10 UL Conduit Box Installation Sheet

1 Safety information



Follow the instructions

The mechanical and electrical installation instructions must be adhered to. Any questions or doubt should be referred to the supplier of the equipment. It is the responsibility of the owner or user to ensure that the installation of the drive and any external option unit, and the way in which they are operated and maintained, comply with any applicable legislation, regulation, and code of practice in the country in which the equipment is used.



Competence of the installer

The drive must be installed by qualified personnel who are familiar with the requirements for safety and EMC. The installer is responsible for ensuring that the end product or system complies with all the relevant laws in the country where it is to be used.

2 Introduction



This document covers the UL conduit box mounting instructions for Unidrive M200 to M702, F300, H300, E200 & E300 frame size 9 & 10 drives.

When fitted, the drive meets the requirement for Type 1 protection according to UL50 and UL50E.

Type 1 enclosures are intended for indoor use only. They provide a degree of protection to personnel against incidental contact with the enclosed equipment and a degree of protection against falling debris.

The following items are supplied in the kit:

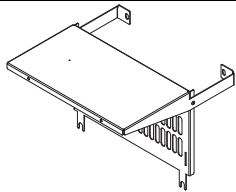
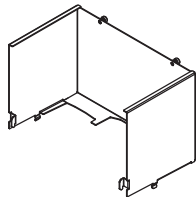
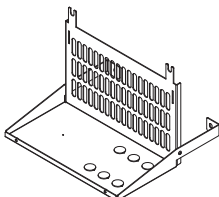
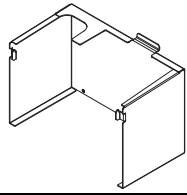
Table 2-1 Contents of the kit (CT part number: 3470-0115)

Description	Image	Qty
AC / DC conduit box		x 1
AC / DC conduit box cover		x 1
Motor / control conduit box		x 1
Motor / control conduit box cover		x 1
UL conduit box installation sheet		x 1

The installed conduit kit does not change the width or depth of the drive. However, this conduit kit will add 395mm (15.5 in) to the height of the drive.

Table 2-2 shows the combined drive and conduit box dimensions.

Table 2-2 Dimensions

Frame size	H		W		D	
	mm	in	mm	in	mm	in
9A	1444	56.9	310	12.2	290	11.4
9E & 10E	1405	55.3	310	12.2	290	11.4

3 Installation



Stored charge

The drive contains capacitors that remain charged to a potentially lethal voltage after the AC and / or DC power supply has been disconnected. If the drive has been energized, the power supply must be isolated at least ten minutes before work may continue.

Normally, the capacitors are discharged by an internal resistor. Under certain, unusual fault conditions, it is possible that the capacitors may fail to discharge, or be prevented from being discharged by a voltage applied to the output terminals. If the drive has failed in a manner that causes the display to go blank immediately, it is possible the capacitors will not be discharged. In this case, consult Control Techniques or their authorized distributor.

Figure 3-1 Removing the drive terminal covers

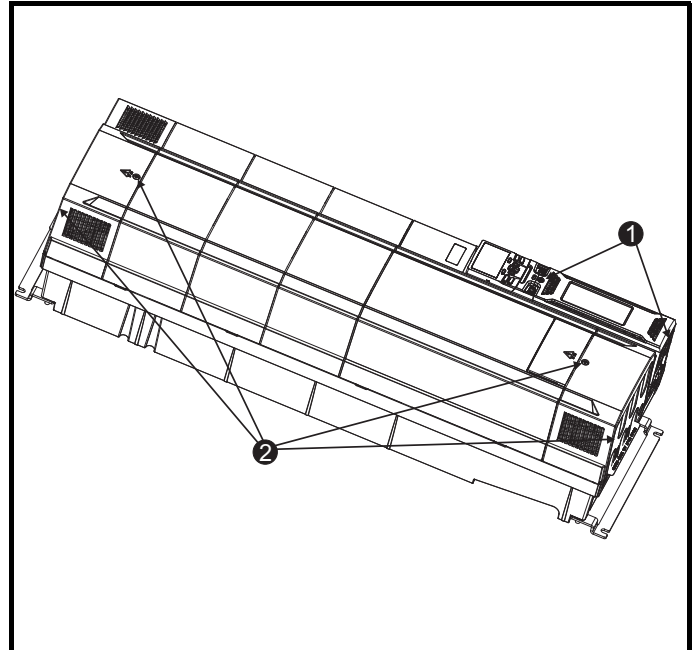

- Remove the control pod cover and the control finger guard (1).
- Remove the drive terminal covers and the terminal finger guards (2).
- Unscrew the M8 ground nut near the +DC and U motor terminals and the M8 ground nut near the PE and L1 supply terminals.



0478-0388-02

Figure 3-2 Installation of motor power conduit connection box

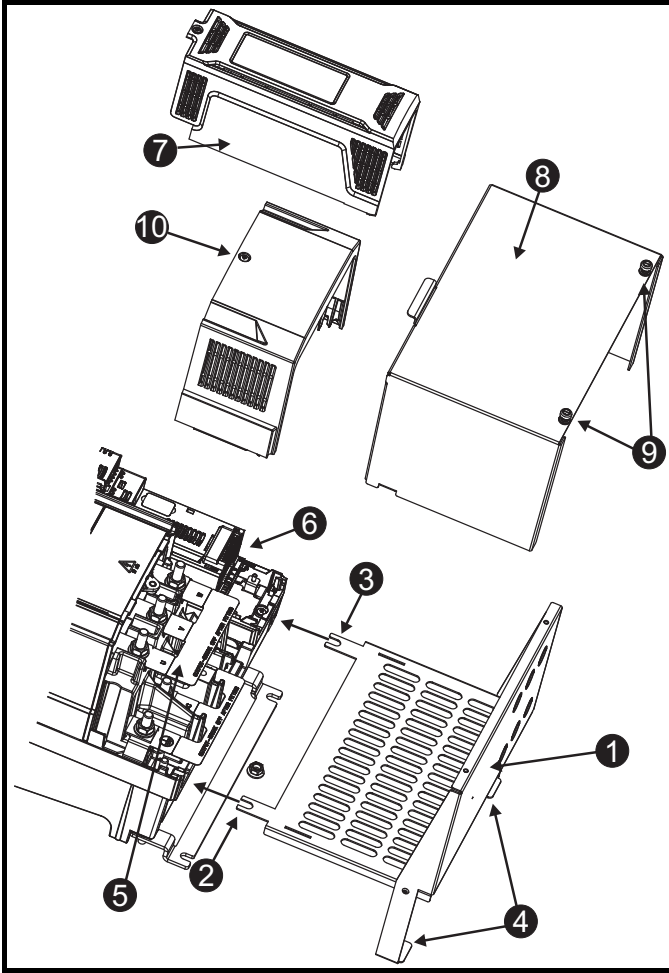
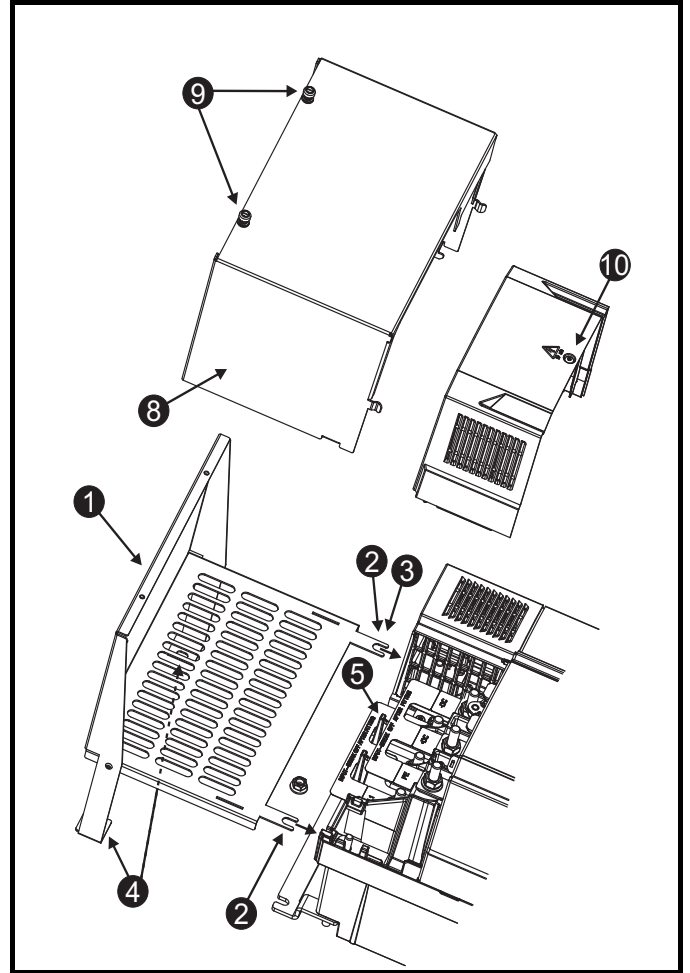

Figure 3-3 Installation of AC power conduit connection box



The following instructions will apply to both the top and bottom terminal access locations.

- Using either the pilot holes or the knockouts provided (1), make appropriately sized holes in the conduit box for the conduit fittings.
- Attach the conduit boxes (2) onto the drive and fasten the M8 nut. Recommended torque is 12 N m (106 lb in) (maximum torque is 14 N m (124 lb in)). Tab (3) is inserted into the size 9A drive (and is *not* fastened with a nut); this tab is fastened with an M8 nut on the size 9E and 10E drives.
- Drill appropriately sized anchor holes into the mounting surface (4). Mount the two bottom conduit feet to the mounting surface using appropriately sized screws (not supplied with this kit).
- Attach conduit fittings to the power conduit box holes (1); run the conduit to the drive. Supply cables, motor cables, and control wires must be run in separate conduits.
- Run the motor cables (U, V & W) and motor ground wire through conduit to the bottom of the drive and then fasten M10 ring terminals, suitable for the wire size, to the motor cables and motor ground wire.
- Run the supply cables (L1, L2 & L3) and supply ground wire through conduit to the top of the drive and then fasten M10 ring terminals, suitable for the wire size, to the supply cables and supply ground wire.
- Connect all wires to their corresponding screw stud using M10 nuts (5). Recommended torque is 15 N m (133 lb in) (maximum torque is 20 N m (177 lb in)).
- Run the control cables through a lower conduit. Connect the control cables to the control terminal (6) as required. Maximum recommended torque for M200 to M400 is 0.2 N m (2 lb in); M600 to M702 is 0.5 N m (4.3 lb in).
- Replace the control pod cover (7). Recommended torque for the cover screw is 1 N m (9 lb in) (maximum torque is 2 N m (18 lb in)).
- Guide the conduit cover over the conduit box (8). Tighten the PEM screws (9). Recommended torque is 2 N m (18 lb in) (maximum torque is 3 N m (26 lb in)).
- Replace the terminal cover (10). Recommended torque for the cover screw is 1 N m (9 lb in) (maximum torque is 2 N m (18 lb in)).

