



Frame 3 to 11

**Unidrive M700/
M701/HS70/HS71**

Universal Variable Speed AC Drive
for induction and permanent magnet
motors

Part Number: 0478-0608-03
Issue: 3



www.controltechniques.com/support

Supporting Information.

This guide provides a fast simple set-up procedure for a drive & motor installation.

For help with more advanced installations: Comprehensive user guides and help tools can be accessed using the web address or QR code below.

Documentation

Control Getting Started Guide

Frame 3 to 4 Power Installation Guide

Frame 5 to 6 Power Installation Guide

Frame 7 to 10 Power Installation Guide

Frame 11 Power Installation Guide

Control User Guide

Parameter Reference Guide

For AFE Applications (Regen Mode) Please use - Unidrive M Regen Design Guide

Software Tools

Diagnostic Tool for Mobile applications

<https://acim.nidec.com/drives/control-techniques/downloads/mobile-applications>

Connect.

Commissioning software.

CT Scope

CTScope is a PC Tool designed to trend/ trace the values of parameters on Control Techniques drives and option modules.

Machine Control Studio.

ON-board PLC and MCI Programming software.

SYTPPro.

SI-Applications Plus & Compact programming software.

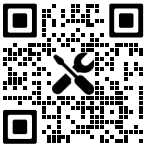

www.controltechniques.com/support

Declaration of Conformity (including 2006 Machinery Directive)

1. Product model

Unidrive-M and derivative products incorporating a Safe Torque Off (STO) function used as a safety component of a machine. Only the Safe Torque Off function may be used as a safety component of a machine.

2. Name and address of the manufacturer and authorised representative

Manufacturer	Authorised representative in the EU
Nidec Control Techniques Ltd The Gro Newtown Powys SY16 3BE UK Registered in England and Wales. Company Reg. No. 01236886 Telephone: 00 44 1686 612000 Email: cthoadmin@mail.nidec.com Web: www.controltechniques.com	Nidec Netherlands B.V. Kubus 155 3364 DG Sliedrecht Netherlands.

3. Responsibility

This declaration is issued under the sole responsibility of the manufacturer.

4. Object of the declaration

Model number	Interpretation	Nomenclature aaaa - bbc dddddd
aaaa	Basic series	M600, M700, M701, M702, M708, M709, M750, M751, M753, M754, F300, F600, H300, E200, E300, HS70, HS71, HS72, CSD1, M880, M881, M882, M889
bb	Frame size	03, 04, 05, 06, 07, 08, 09, 10, 11, 12
c	Voltage rating	1 = 100 V, 2 = 200 V, 4 = 400 V, 5 = 575 V, 6 = 690 V
dddd	Current rating	Example 01000 = 100 A
e	Drive format	A = 6P Rectifier + Inverter with internal choke, D = Inverter, E = 6P Rectifier + Inverter, T = 12P Rectifier + Inverter

The model number may be followed by additional characters that do not affect the ratings.

(Refer to the Revision List: 01_205_5270_03_22_RL_2022_08_24.docx).

5. Declaration

The safety function STO within the Unidrive-M series fulfils the requirements of SIL 3 of EN 61800-5-2 / EN 61508 and Cat 4 / PLe of EN ISO 1384901 and can be used in safety related applications up to these safety levels and in the application area of EN IEC 62061:2021.

Further it can be used for electric passenger and goods lifts within the scope of EN 81-20, clause 5.9.2.5.4 d) as a SIL 3 drive control featuring a defined interface for stopping of the drive by a means of static elements.

The object of the declaration is in conformity with the following European Union harmonisation legislation: Machinery Directive (2006/42/EC)

Electromagnetic Compatibility Directive (2014/30/EU)

Type examination has been carried out by the following notified body:

TUV Rheinland Industrie Service GmbH, Am Grauen Stein, D-51105 Köln, Germany

Notified body identification number: 0035

EC type-examination certificate number: 01/205/5270.03/22 dated 2022-08-26, valid until 2027-08-26.

6. References to the relevant harmonised standards used

The variable speed drive products listed above have been designed and manufactured in accordance with the following European harmonised standards:

EN 61800-5-2:2017	Adjustable speed electrical power drive systems - Part 5-2: Safety requirements - Functional
EN 61800-5-1:2007 + A1: 2017 + A11: 2021, 4.3, 5.2.3.8, 5.2.6	Adjustable speed electrical power drive systems - Part 5-1: Safety requirements - Electrical, thermal and energy
EN ISO 13849-1:2015	Safety of Machinery, Safety-related parts of control systems, General principles for design
EN 61508 Parts 1 - 7:2010	Functional safety of electrical/ electronic/programmable electronic safety-related systems

7. Responsible person

Person authorised to complete the technical file: Authorised representative (see details above)

DoC authorised by:



Jon Holman-White, Vice President, Research and Development.

Date:

13th November 2023, Newtown, Powys, UK

IMPORTANT NOTICE

These electronic drive products are intended to be used with appropriate motors, controllers, electrical protection components and other equipment to form complete power drive system (PDS).

It is the responsibility of the installer to ensure that the design of the system and machine, including its safety-related control system, is carried out in accordance with the requirements of the Machinery Directive and any other relevant legislation.

The use of a safety component does not ensure the safety of the machine.

Compliance with safety and EMC regulations depends upon installing and configuring drives correctly, including using the specified input filters.

The drive must be installed only by professional installers who are familiar with requirements for safety and EMC.

The assembler is responsible for ensuring that the final product or system complies with all relevant laws in the country where it is to be used. For more information regarding Safe Torque Off, refer to the Product Documentation.

Safety Information

Electric shock risk

The voltages present in the following locations can cause severe electric shock and may be lethal:

AC supply cables and connections

DC and brake cables, and connections

Output cables and connections







Many internal parts of the drive, and external option units

Unless otherwise indicated, control terminals are single insulated and must not be touched.



Stored Charge



The drive contains capacitors that remain charged to a potentially lethal voltage after the AC and / or DC power supply has been disconnected. If the drive has been energized, the AC and / or DC power supply must be isolated at least ten minutes before work may continue. Normally, the capacitors are discharged by an internal resistor. Under certain, unusual fault conditions, it is possible that the capacitors may fail to discharge, or be prevented from being discharged by a voltage applied to the output terminals. If the drive has failed in a manner that causes the display to go blank immediately, it is possible the capacitors will not be discharged. In this case, consult Nidec Industrial Automation or their authorized distributor.



Rating descriptions

	CE Approval	Europe
	RCM Regulatory compliance mark	Australia & New Zealand
	UL / cUL approval	USA & Canada
	RoHS compliant	Europe
	Functional safety	USA & Canada
	Eurasian conformity	Eurasia
	UKCA Approval	UK
	China RoHS	China

Rating label



LISTED8D14
E171230
Ind. Cont.
Equipment

← Approvals



	Input frequency		Date code
	M700-094 02240 A10	110/132kW	2304
Input voltage →	IP 380-480V	50-60Hz	3ph 370A
Output voltage →	O/P 0-480V	0-550Hz	3ph 224/266A
			← No. of phases & typical current for Normal duty rating
	S/N: 300005001 IP20		← Output voltage
	Control Techniques, The Gro, Pool Road, Newtown, Powys, United Kingdom, SY16 3BE		
	Made in U.K.		Patents: www.ctpatents.info Manuals: www.ctmanuals.info

110/132kW
IP 380-480V 50-60Hz 3ph 245A O/P 0-480V 0-550Hz 3ph 224/266A

S/N: 300005001



Model

M700-094 02240 A10

Mounting the drive

Ambient temperature operating range -20 °C to 50 °C (-4 °F to 122 °F)

Output current de-rating maybe required at ambient temperatures >40 °C (104 °F). **Refer to the Power Installation Guide for further details.** For UL Installations, the maximum ambient temperature permitted is 50 °C (122 °F) with any specified derating applied.

Drives can be panel mounted or with additional kits through panel mounted. For through panel mounting, **Refer to the Power Installation Guide for further details.**

Drive Dimensions & Clearances

Frame 3 illustrated

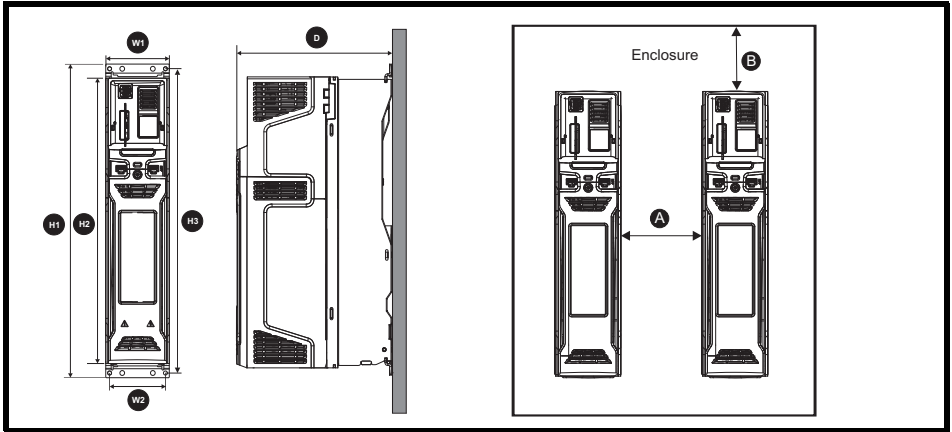

Frame	H1 mm (in)	H2 mm (in)	H3 mm (in)	W1 mm (in)	W2 mm (in)	D mm (in)	Mounting hole diameter	Weight kg (lb)	Clearance	
									A	B
									40 °C	
3 03400078 / 03400100	382	365	370	83	73	200	5.5	4.5	0	0
	(15.04)	(14.37)	(14.57)	(3.27)	(2.87)	(7.87)	(0.22)	(9.9)	0	0
3 All other variants	382	365	370	83	73	200	5.5	4	0	0
	(15.04)	(14.37)	(14.57)	(3.27)	(2.87)	(7.87)	(0.22)	(8.8)	0	0
4	391	365	375	124	106	200	6.5	6.5	0	30 mm
	(15.39)	(14.37)	(14.76)	(4.88)	(4.17)	(7.87)	(0.26)	(14.3)	0	1.18 in
5	391	365	375	143	106	200	6.5	7.4	0	30 mm
	(15.39)	(14.37)	(14.76)	(5.63)	(4.17)	(7.87)	(0.26)	(16.3)	0	1.18 in
6	391	365	378	210	196	227	7	14	0	30 mm
	(15.39)	(14.37)	(14.88)	(8.27)	(7.72)	(8.94)	(0.27)	(30.9)	0	1.18 in
7	557	508	538	270	220	280	9	28	30 mm	30 mm
	(21.93)	(20)	(21.18)	(10.63)	(8.66)	(11.02)	(0.35)	(61.7)	1.18 in	1.18 in
8	804	753	794	310	259	290	9	52	30 mm	30 mm
	(31.65)	(29.65)	(31.26)	(12.21)	(10.20)	(11.42)	(0.35)	(114.6)	1.18 in	1.18 in
9A	1108	1049	1090	310	259	290	9	66.5	60 mm	45 mm
	(43.61)	(41.30)	(42.91)	(12.21)	(10.20)	(11.42)	(0.35)	(146.6)	2.37 in	1.77 in
9E and 10E	1069	1010	1051	310	259	290	9	46	60 mm	45 mm
	(42.09)	(39.70)	(41.38)	(12.21)	(10.20)	(11.42)	(0.35)	(101.4)	2.37 in	1.77 in
11E	1242	1190	1222	310	259	313	9	63		45 mm
	(48.9)	(46.9)	(48.11)	(12.21)	(10.20)	(12.32)	(0.35)	(138.9)		1.77 in

Fuse & Cable selection

Model	Max. cont. input current	Fuse				Cables				
		IEC		UL		IEC60364-5-52 mm ²		UL508C AWG or kcmil		
		3ph	Nom	Class	Nom	Class	Input	Output	Input	Output
		A	A		A					
03200050	10.7	16	gG	16	CC*, J or T**	1.5	1.5	14	14	
03200066	13	20		20		1.5	1.5	14	14	
03200080	17.8	25		25		4	4	12	12	
03200106	20.6	25		25		4	4	12	12	
03400025	5	6		10		1.5	1.5	18	18	
03400031	6.6	10		10		1.5	1.5	16	16	
03400045	9.1	10		10		1.5	1.5	14	14	
03400062	13.1	20		20		2.5	2.5	14	14	
03400078	13.4	20		20		2.5	2.5	14	14	
03400100	15.8	20		20		2.5	2.5	12	12	
04200137	20.1	25		25		6	6	10	10	
04200185	26.8	32		30		8	8	8	8	
04400150	18.7	25		25		4	4	10	10	
04400172	24.3	32		30		6	6	8	8	
05200250	31	40		40		10	10	8	8	
05400270	29	40		35		6	6	8	8	
05400300	29	40		35		6	6	8	8	
05500030	4.3	10		10		0.75	0.75	16	16	
05500040	5.7	10		10		1	1	14	14	
05500069	9.3	20		20		1.5	1.5	14	14	
06200330	48.8	63		60		16	16	4	4	
06200440	56.6	63		60		25	25	3	3	
06400350	36	63		40		10	10	6	6	
06400420	46	63		50		16	16	4	4	
06400470	60	63		60		25	25	3	3	
06500100	13.2	20		20		2.5	2.5	14	14	
06500150	18.7	32		25		4	4	10	10	
06500190	24.3	40		30		6	6	10	10	
06500230	29.4	50	35	10	10	8	8			
06500290	37.1	50	40	10	10	6	6			
06500350	46.9	63	50	16	16	6	6			
07200610	67	80	80	35	35	2	2			
07200750	84	100	100	35	35	1	1			
07200830	105	125	125	70	70	1/0	1/0			
07400660	74	100	80	35	35	1	1			
07400770	88	100	100	50	50	2	2			
07401000	105	125	125	70	70	1/0	1/0			
07500440	45	50	50	16	16	4	4			
07500550	62	80	80	25	25	3	3			
07600060	10	16		2.5	1.5					
07600100	16	16		2.5	1.5					
07600190	20	25		10	10					
07600240	26	32		10	10					
07600290	31	40		10	10					
07600380	39	50		16	16					
07600440	44	50		16	16					
07600540	62	80		25	25					

08201160	137	200	gR	200	HSJ (Mersen) DFJ (Bussmann)	95	95	3/0	3/0
08201320	166	200		225		2 x 70	2 x 70	2 x 1	2 x 1
08401340	155	250		225		2 x 50	2 x 50	2 x 1	2 x 1
08401570	177	250		225		2 x 70	2 x 70	2 x 1/0	2 x 1/0
08500630	83	125		100		35	35	1	1
08500860	104	160		150		50	50	1	1
08600630	83	125				50	50		
08600860	104	160				70	70		
09201760	205	250	gR	250	HSJ (Mersen) DFJ (Bussmann)	2 x 70 (B1)	2 x 95 (B2)	2 x 2/0	2 x 2/0
09202190	260	315		300		2 x 95 (B1)	2 x 120 (B2)	2 x 4/0	2 x 4/0
09402000	232	315		300		2 x 70 (B1)	2 x 95 (B2)	2 x 3/0	2 x 2/0
09402240	267	315		350		2 x 95 (B1)	2 x 120 (B2)	2 x 4/0	2 x 4/0
09501040	166	150		150		2 x 70 (B2)	2 x 35 (B2)	2 x 1	2 x 3
09501310	166	200		175		2 x 70 (B2)	2 x 50 (B2)	2 x 1	2 x 1
09601040	149	150				2 x 50 (B2)	2 x 35 (B2)		
09601310	171	200				2 x 70 (B2)	2 x 50 (B2)		
10202830	305	400		400		2 x 120 (B1)	2 x 120 (C)	2 x 300	2 x 250
10203000	361	450		450		2 x 150 (C)	2 x 120 (C)	2 x 300	2 x 300
10402700	332	400		400		2 x 120 (C)	2 x 120 (B2)	2 x 300	2 x 250
10403200	397	450		450		2 x 150 (C)	2 x 150 (B2)	2 x 350	2 x 300
10501520	197	250		250		2 x 70 (B2)	2 x 70 (B2)	2 x 2/0	2 x 2/0
10501900	218	250		250		2 x 95 (B2)	2 x 70 (B2)	2 x 2/0	2 x 2/0
10601500	202	225				2 x 70 (B2)	2 x 70 (B2)		
10601780	225	250				2 x 95 (B2)	2 x 70 (B2)		
11403770	449	500		600		2 x 150	2 x 150	2 x 300	2 x 300
11404170	492	500		600		2 x 150	2 x 185	2 x 300	2 x 350
11404640	539	550		600		2 x 150	2 x 185	2 x 300	2 x 350
11502000	265	400		400		2 x 120	185	2 x 4/0	350
11502540	310	400		400		2 x 120	2 x 120	2 x 4/0	2 x 4/0
11502850	338	400		400		2 x 120	2 x 120	2 x 4/0	2 x 4/0
11602100	256	400				2 x 120	185		
11602380	302	400				2 x 120	2 x 120		
11602630	329	400				2 x 120	2 x 120		

* CC class fuse rating up to 30 A

** These fuses are fast acting

The product is UL listed for use on a circuit up to 100 kA maximum supply symmetrical fault current when protected by fuses.

IEC cable sizes assume copper conductor. PVC insulation method B2 and ambient temperature of 40 °C (104 °F) UL cable sizes assume copper conductor with insulation rated at 75 °C.

Protective ground cable rating

Input phase conductor size	Minimum ground conductor size
$\leq 10 \text{ mm}^2$	Either 10 mm^2 or two conductors of the same cross-sectional area as the input phase conductor.
$> 10 \text{ mm}^2$ and $\leq 16 \text{ mm}^2$	The same cross-sectional area as the input phase conductor.
$> 16 \text{ mm}^2$ and $\leq 35 \text{ mm}^2$	16 mm^2 .
$> 35 \text{ mm}^2$	Half of the cross-sectional area of the input phase conductor.

Removing terminal covers

Control terminal covers on Frame 3 and Frame 4

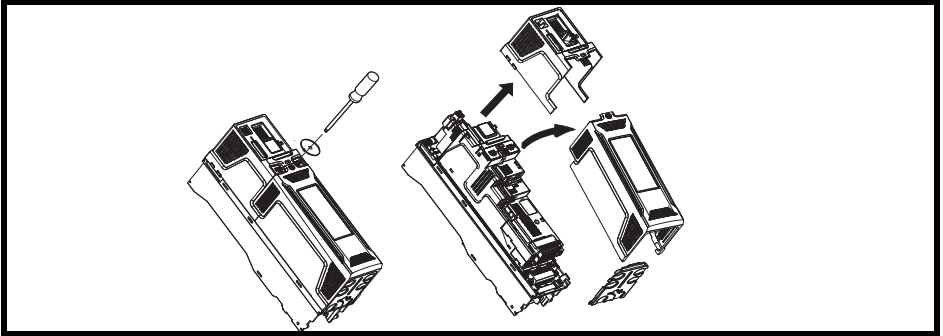

Frame 5

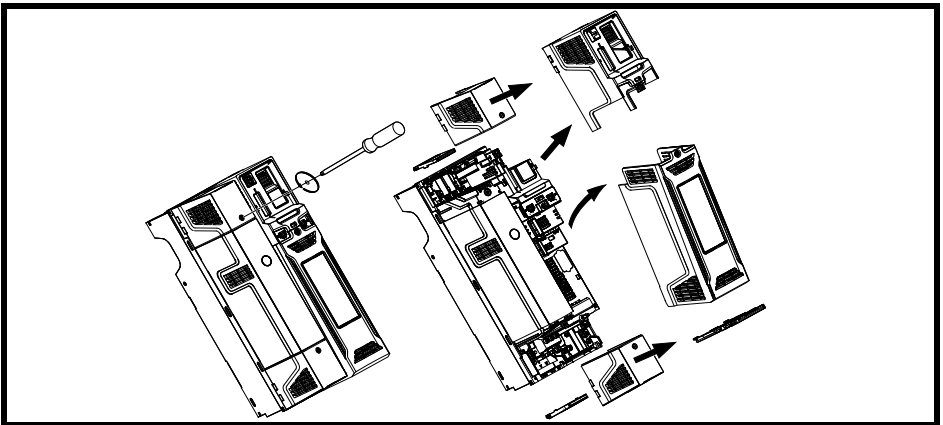

Frame 6 to 11

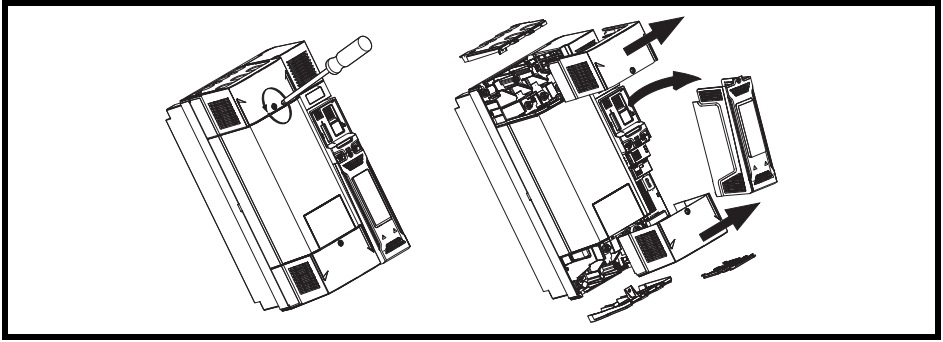

Torque settings - Terminal Covers, all frame sizes

The terminal cover screws should be tightened to a maximum torque of 1 N m (6 lb in) when being refitted.

Drive Features

Drive size 3 to 6

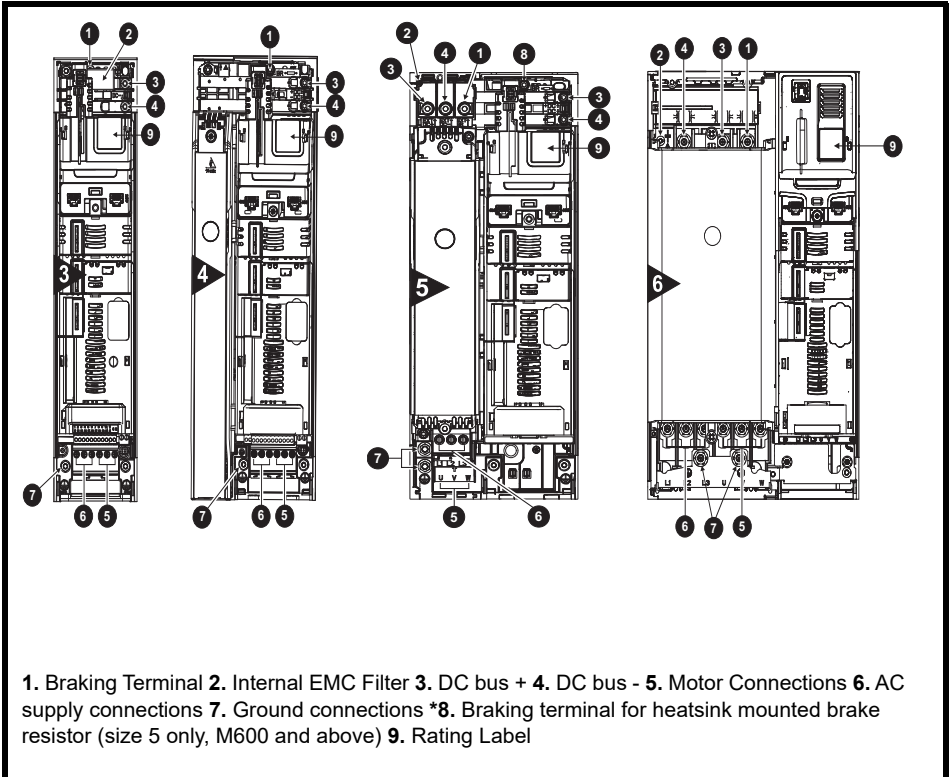

Drive Features (Cont.) Drive size 7 to 11

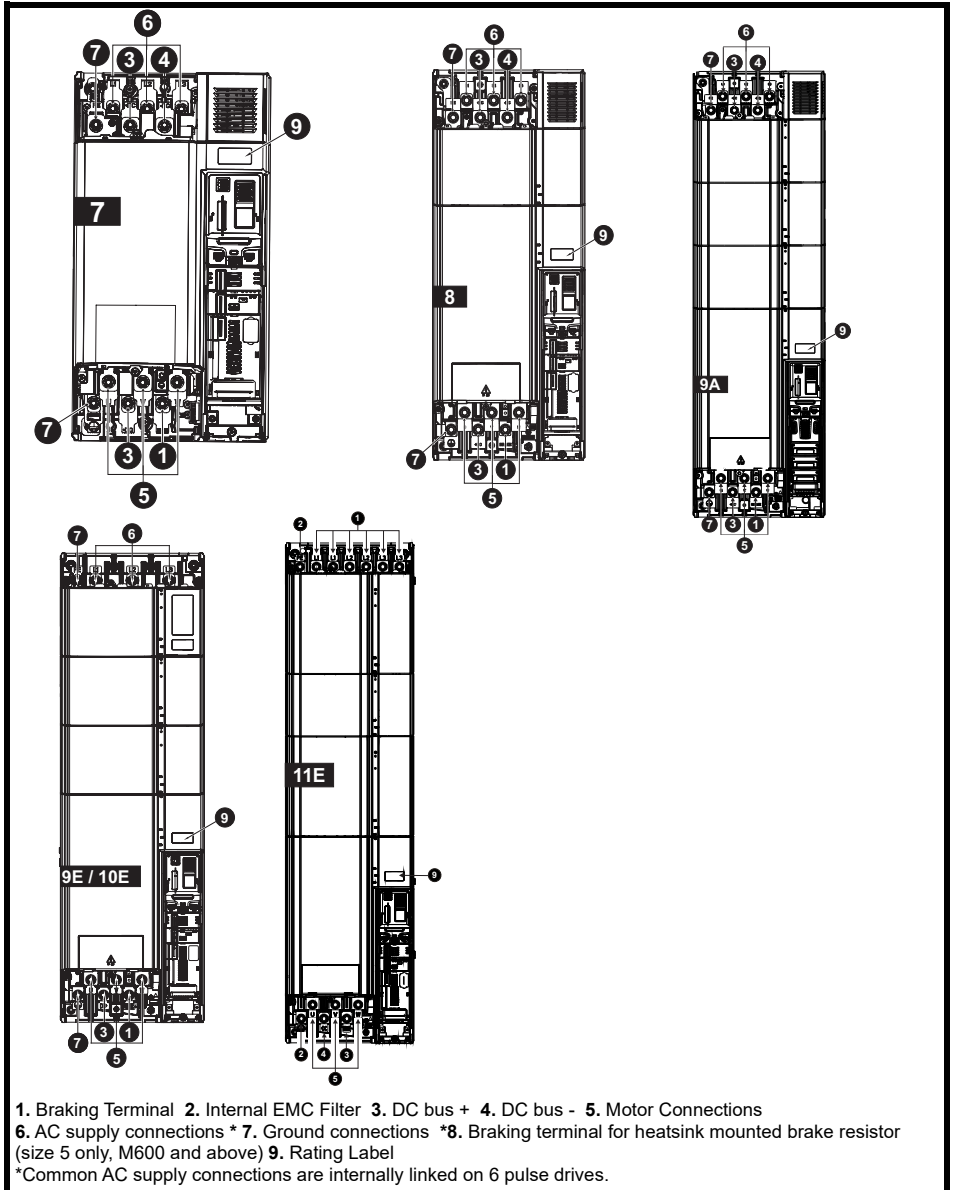

Torque settings - Heatsink mounted braking resistors - frame sizes 3 to 5

Heatsink mounted braking resistors mounting screws should be tightened to a maximum torque of 2 N m (16.8 lb in).

The brake terminals should be tightened to a maximum torque setting of 2 N m (16.8 lb in).

Power & Ground Connections

Frame 3

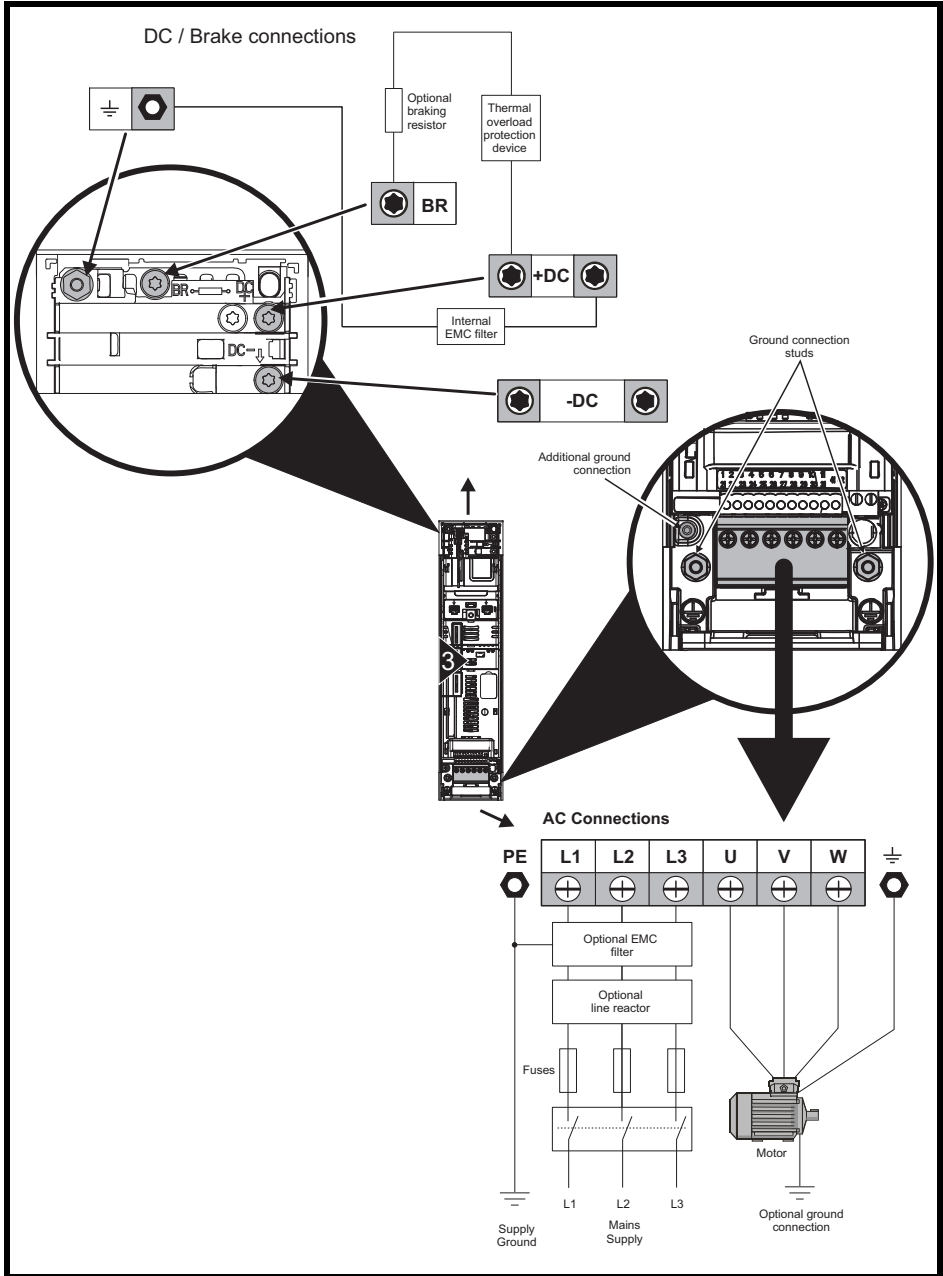

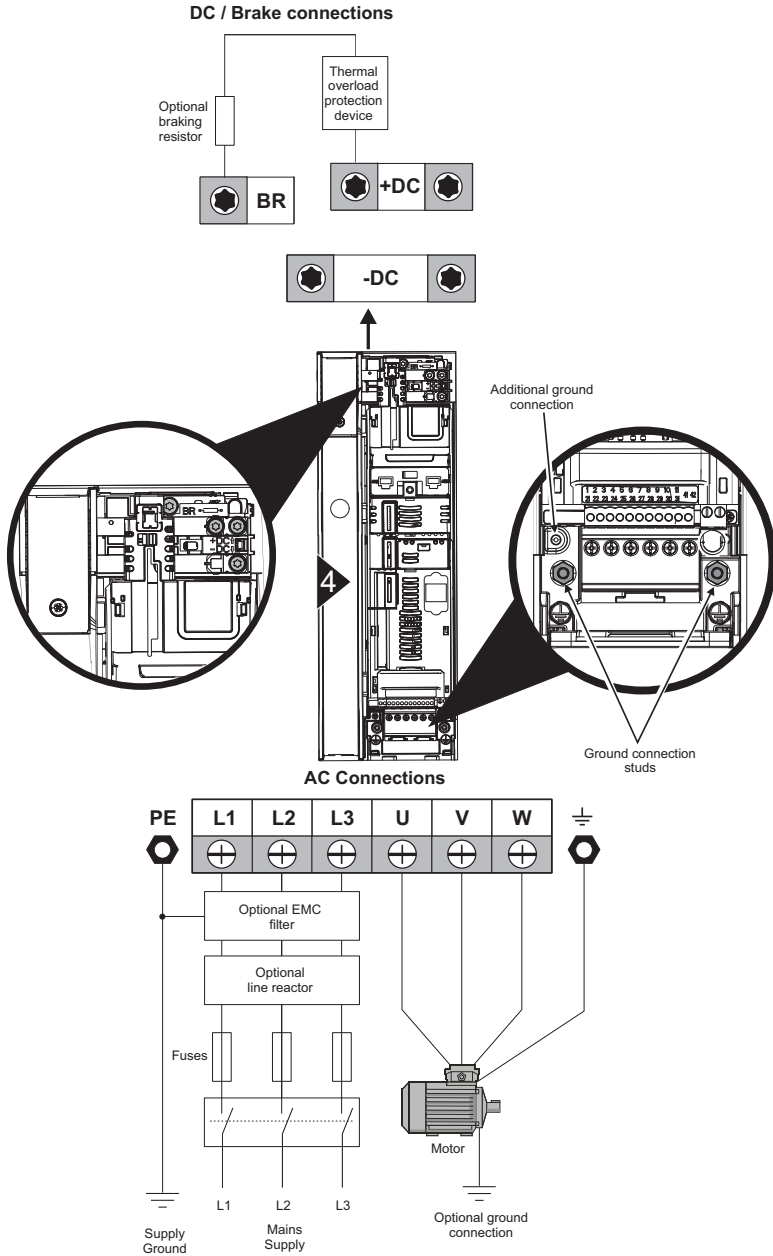

DC / Brake connections

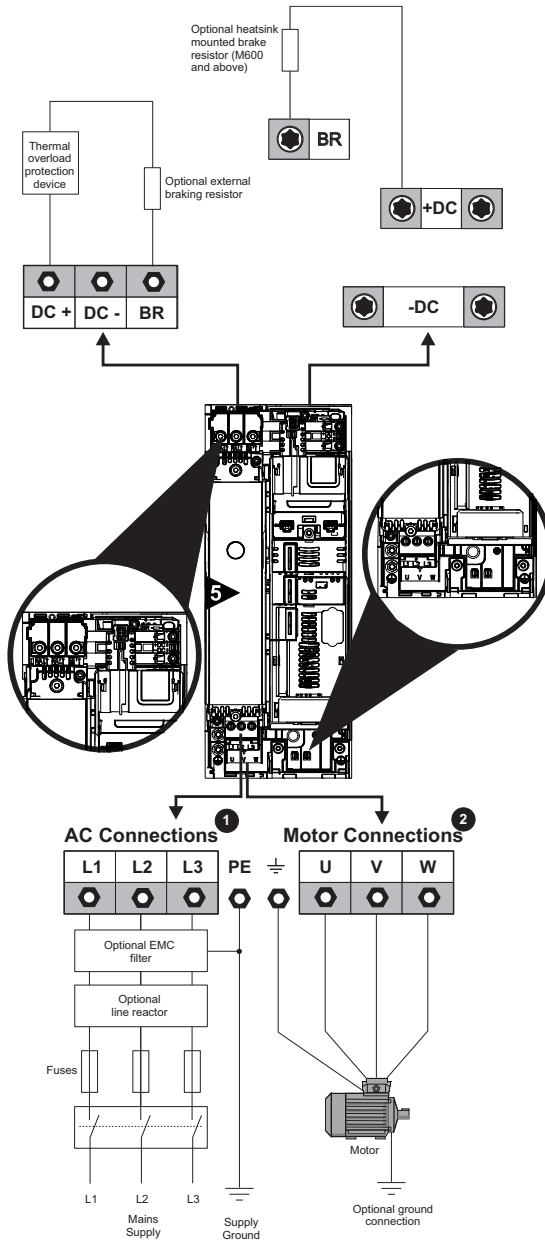

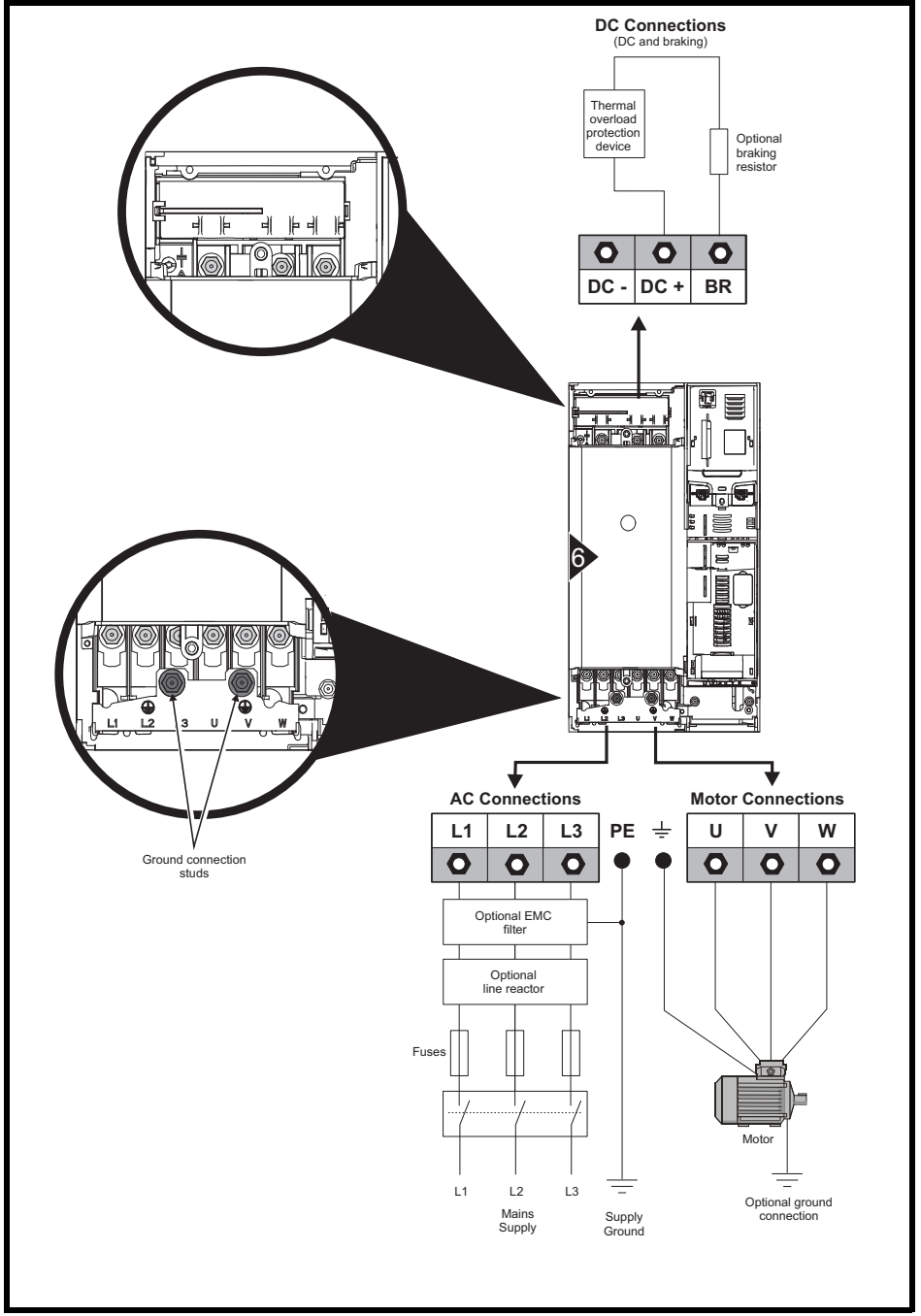

Frame 7 and 8 (Frame 7 shown)

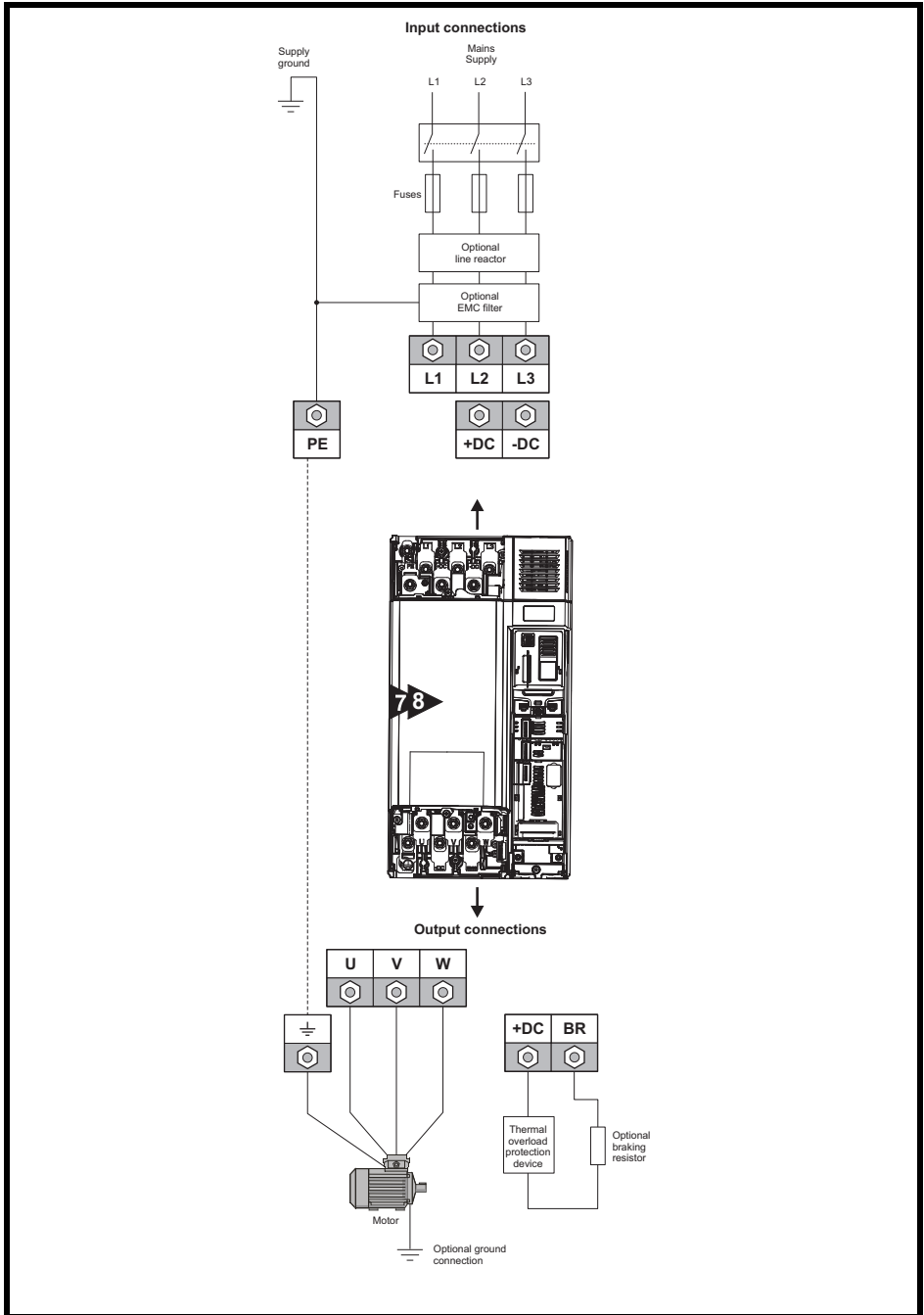

Frame 9A

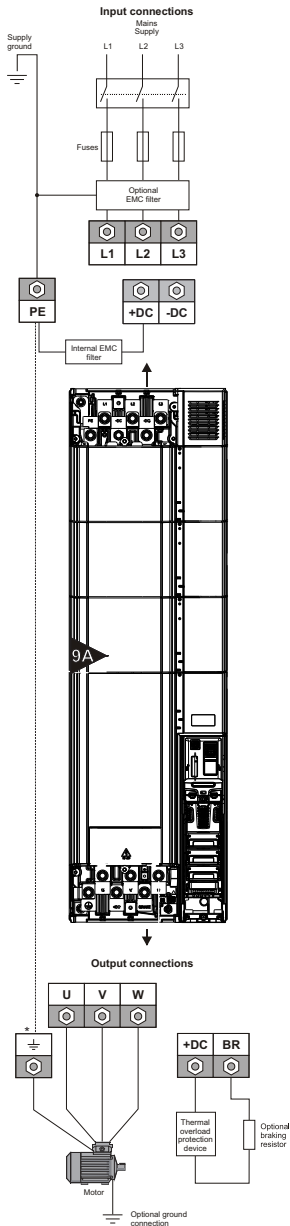

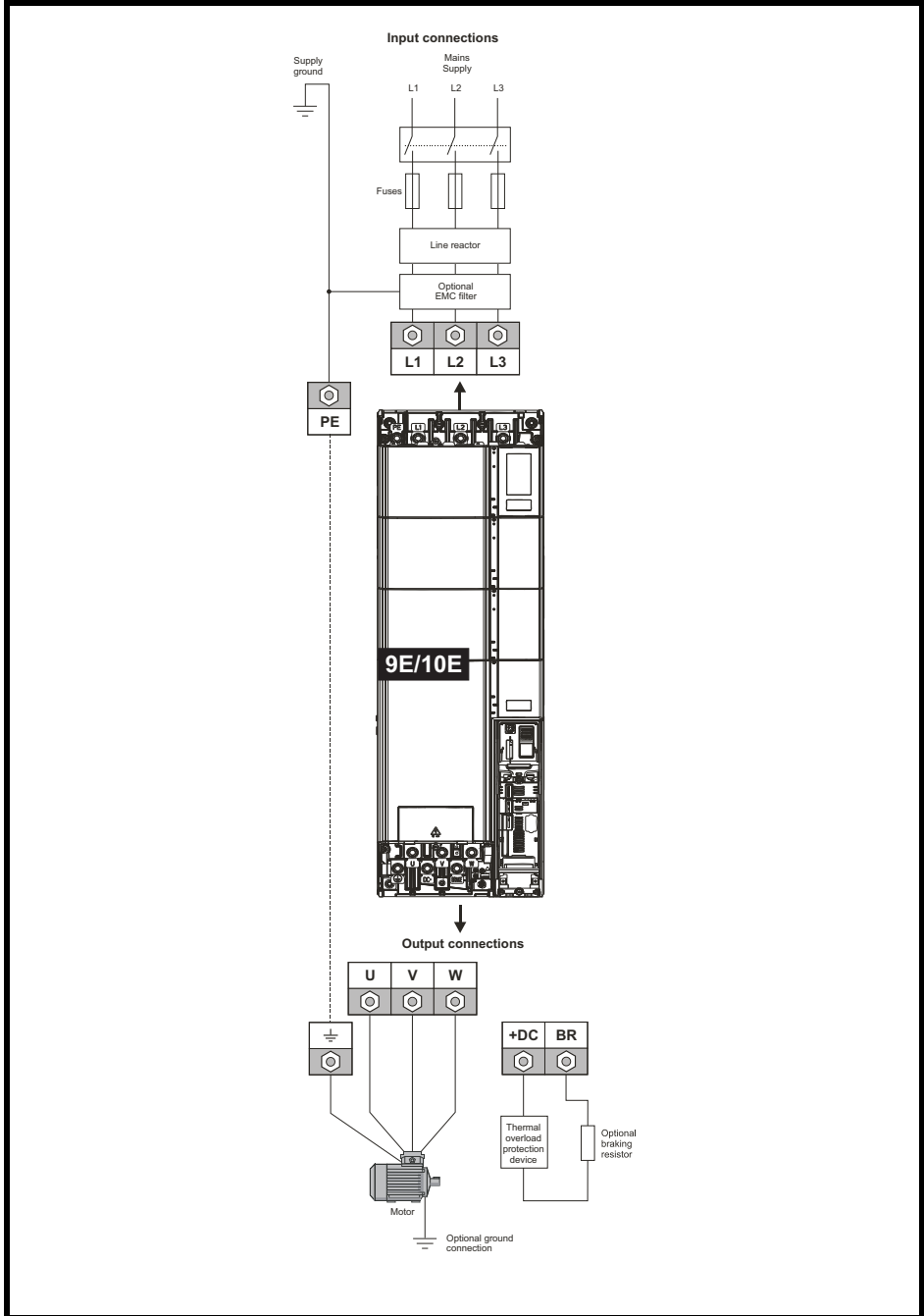

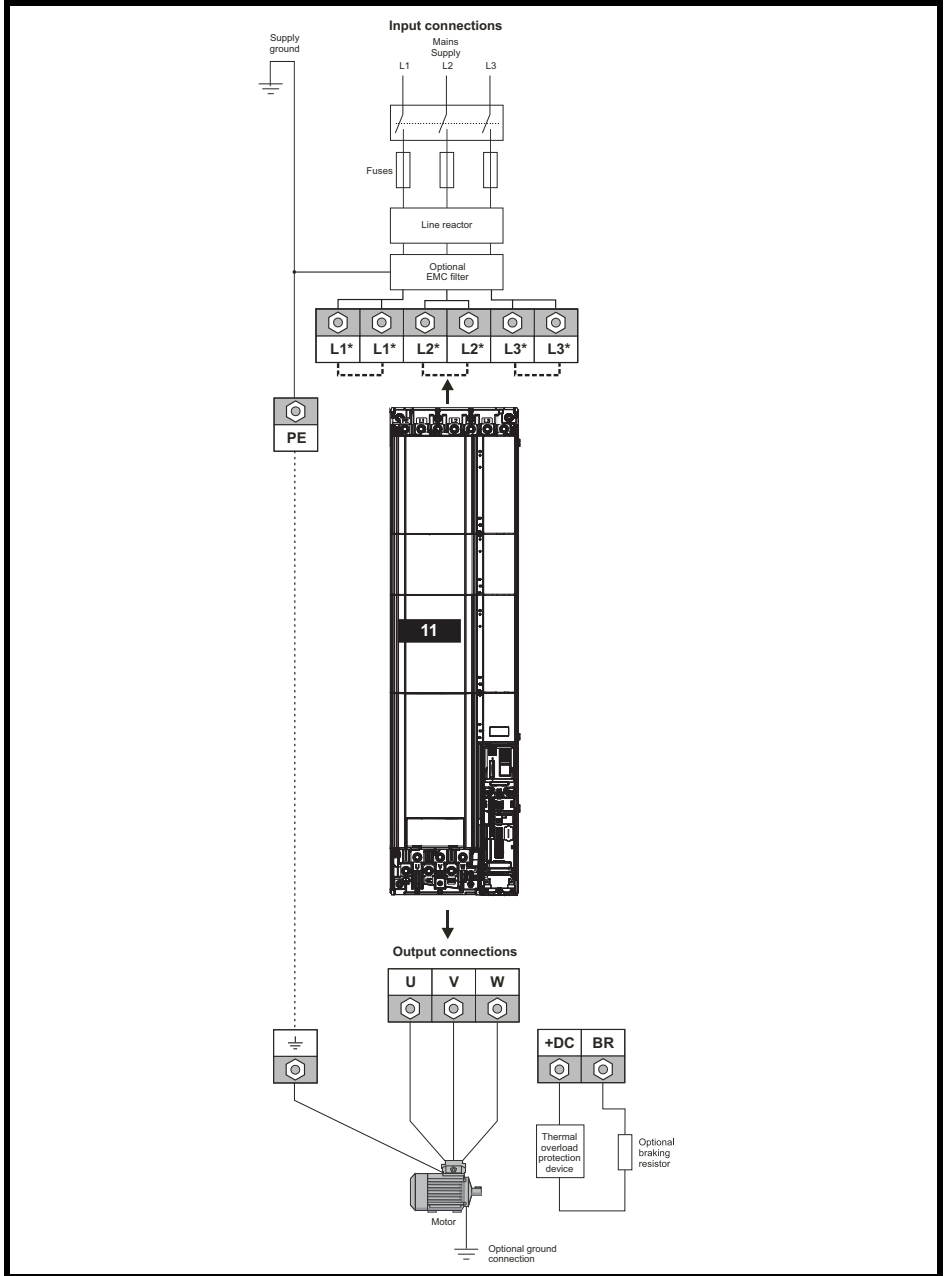

Torque Setting - Power terminals

Frame size	AC and Motor terminals		DC and braking		Ground terminal	
	Recommended	Maximum	Recommended	Maximum	Recommended	Maximum
3 and 4	Plug-in terminal block		T20 Torx (M4)		T20 Torx (M4) / M4 Nut (7 mm AF)	
	0.7 N m (6 lb in)	0.8 N m (7.2 lb in)	2.0 N m (16.8 lb in)	2.5 N m (21.6 lb in)	2.0 N m (16.8 lb in)	2.5 N m (21.6 lb in)
5	Plug-in terminal block		T20 Torx (M4) / M4 Nut (7 mm AF)		M5 Nut (8 mm AF)	
	1.5 N m (13.2 lb in)	1.8 N m (15.6 lb in)	1.5 N m (13.2 lb in)	2.5 N m (21.6 lb in)	2.0 N m (18 lb in)	5.0 N m (44.4 lb in)
6	M6 Nut (10 mm AF)					
	6.0 N m (52.8 lb in)	8.0 N m (72 lb in)	6.0 N m (52.8 lb in)	8.0 N m (72 lb in)	6.0 N m (52.8 lb in)	8.0 N m (72 lb in)
7	M8 Nut (13 mm AF)		M8 Nut (13 mm AF)		M8 Nut (13 mm AF)	
	12 N m (106.2 lb in)	14 N m (124 lb in)	12 N m (106.2 lb in)	14 N m (124 lb in)	12 N m (106.2 lb in)	14 N m (124 lb in)
8 to 10	M10 Nut (17 mm AF)		M10 Nut (17 mm AF)		M10 Nut (17 mm AF)	
	15 N m (133.2 lb in)	20 N m (177.6 lb in)	15 N m (133.2 lb in)	20 N m (177.6 lb in)	15 N m (133.2 lb in)	20 N m (177.6 lb in)
11	M10 Nut (17 mm AF)		M10 Nut (17 mm AF)		M10 Nut (17 mm AF)	
	15 N m (133.2 lb in)	20 N m (177.6 lb in)	15 N m (133.2 lb in)	20 N m (177.6 lb in)	15 N m (133.2 lb in)	20 N m (177.6 lb in)

Torque Setting - Control Block Terminals

Model	Connection Type	Torque setting
All	Plug-in relay terminals	0.52 Nm (4.6 lb in)
	Plug-in drive control terminals	0.2 Nm (1.8 lb in)
Frames 6 to 11	Terminals 51, 52 24 V backup supply	0.2 Nm (1.8 lb in)
Frames 9 to 11	Terminals 61, 62 Heatsink fan 24 V supply	0.284 Nm (2.51 lb in)

Control Connections

- Refer to Back Cover

Torque Setting - Optional external EMC filters

Frame size	CT part number	Power connections			Ground connections	
		Bar hole diameter	Max cable size	Max torque	Ground stud size	Max torque
3 and 4	4200-3230		4 mm ² (12 AWG)	0.8 N m (7.2 lb in)	M5	5.5 N m (48.7 lb in)
	4200-3480					
	4200-0252		6 mm ² (10 AWG)	1.8 N m (15.6 lb in)	M6	5.0 N m (44.4 lb in)
	4200-0272					
5 and 6	4200-0122		6 mm ² (8 AWG)	1.8 N m (15.6 lb in)	M6	5.0 N m (44.4 lb in)
	4200-0312					
	4200-0402					
	4200-2300		16 mm ² (6 AWG)	2.3 N m (20.4 lb in)	M6	5.0 N m (44.4 lb in)
	4200-4800					
	4200-3690					
7 to 10	4200-1132		50 mm ² (1/0 AWG)	8.0 N m (72 lb in)	M10	18 N m (159.3 lb in)
	4200-0672					
	4200-1972		95 mm ² (3/0 AWG)	20 N m (177.6 lb in)		
	4200-1662					
	4200-3021	10.8 mm		30 N m (265.5 lb in)		
	4200-1660					
	4200-4460	11 mm				
	4200-2210					
11	4200-0400	10.5 mm		30 N m (265.5 lb in)	M12	25 N m (221.3 lb in)
	4200-0690					

Encoder & Communications connections

Location of Encoder & Communications connections

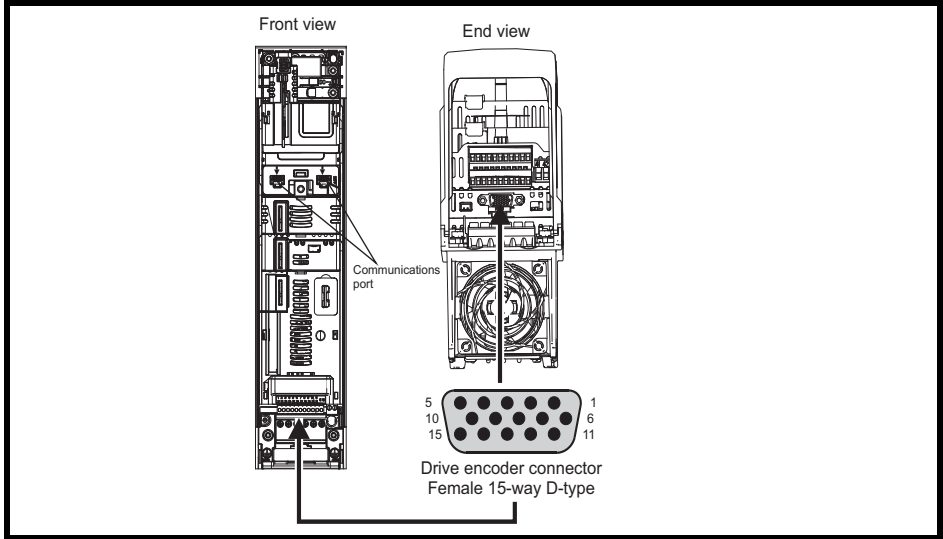

Encoder connections

P1 Position feedback	Connections														
	1	2	3	4	5	6	7	8	9	10	11	12	13	14	15
AB (0)	A	A\	B	B\	Z	Z\									
FD (1)	F	F\	D	D\	Z	Z\									
FR (2)	F	F\	R	R\	Z	Z\									
AB Servo (3)	A	A\	B	B\	Z	Z\	U	U\	V	V\	W	W\			
FD Servo (4)	F	F\	D	D\	Z	Z\	U	U\	V	V\	W	W\			
FR Servo (5)	F	F\	R	R\	Z	Z\	U	U\	V	V\	W	W\			
SC (6)	A (Cos)	A\ (Cos\)	B (Sin)	B\ (Sin\)	Z	Z\									
SC Hiperface (7)	Cos	Cosref	Sin	Sinref	DATA	DATA\									
EnDat (8)	DATA	DATA\	CLK	CLK\	Frz* ³	Frz\ ³									
SC EnDat (9)	A	A\	B	B\	DATA	DATA\					CLK	CLK\	+V ⁴		
SSI (10)	DATA	DATA\	CLK	CLK\	Frz* ³	Frz\ ³									
SC SSI (11)	A (Cos)	A\ (Cos\)	B (Sin)	B\ (Sin\)	DATA	DATA\					CLK	CLK\		0 V	Th
SC Servo (12)	A (Cos)	A\ (Cos\)	B (Sin)	B\ (Sin\)	Z	Z\	U	U\	V	V\	W	W\			
BISS (13)	DATA	DATA\	CLK	CLK\	Frz* ³	Frz\ ³									
Resolver (14)	Cos	Cos L	Sin	Sin L	Ref H	Ref L									
SC SC (15)	A (Cos)	A\ (Cos\)	B (Sin)	B\ (Sin\)	Z	Z\	C* ¹	C\ ¹	D* ²	D\ ²	Frz2* ₃	Frz2\ ₃			
Commutation Only (16)							U	U\	V	V\	W	W\			
SC BISS (17)	A (Cos)	A\ (Cos\)	B (Sin)	B\ (Sin\)	DATA	DATA\					CLK	CLK\	+V		
EnDat Alt (18)					DATA	DATA\					CLK	CLK\			
SSI Alt (19)					DATA	DATA\					CLK	CLK\			
BISS Alt (20)					DATA	DATA\					CLK	CLK\			

*1 - One sine wave per revolution

*2 - One cosine wave per revolution

*3 - Freeze inputs are shown on the table above as 'Frz'

*4 - The encoder power supply is selectable through parameter configuration to 5 Vdc, 8 Vdc and 15 Vdc

Th - Thermistor input

Greyed cells are for P2 position feedback connections or simulated encoder outputs. Refer to the *Drive User Guide* for further information.

NOTE

Frz and Frz\ on terminals 5 and 6 are for Freeze input 1. Frz2 and Frz2\ on terminals 11 and 12 are for Freeze input 2.

Communications

The Unidrive-M700/HS70 Product offers Ethernet fieldbus communications and the Unidrive-M701/HS71 offers 2-wire EIA-485 Interface.

Keypad Operation

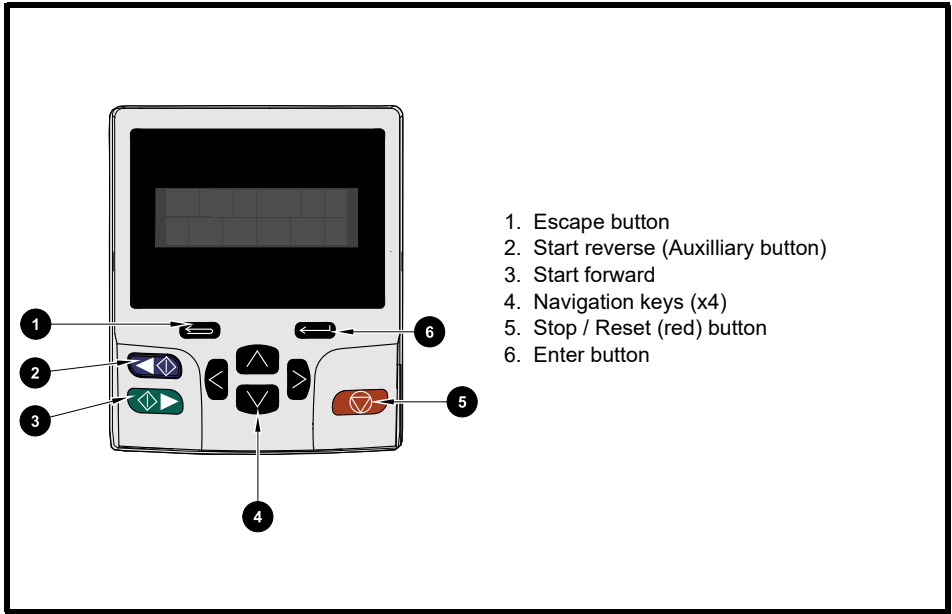

Display modes

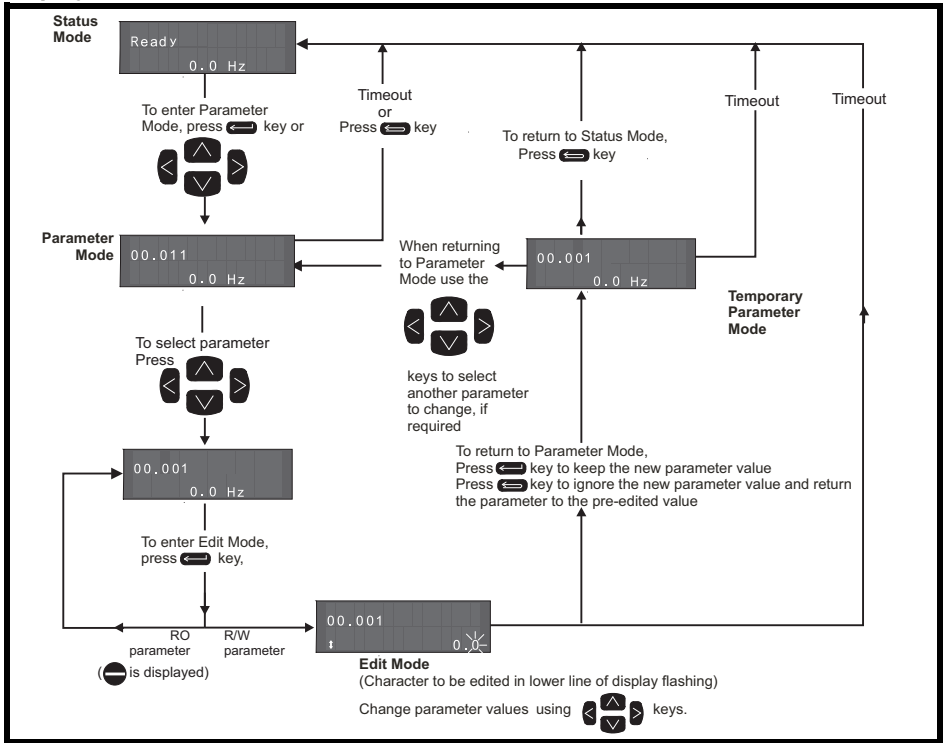

Display icons





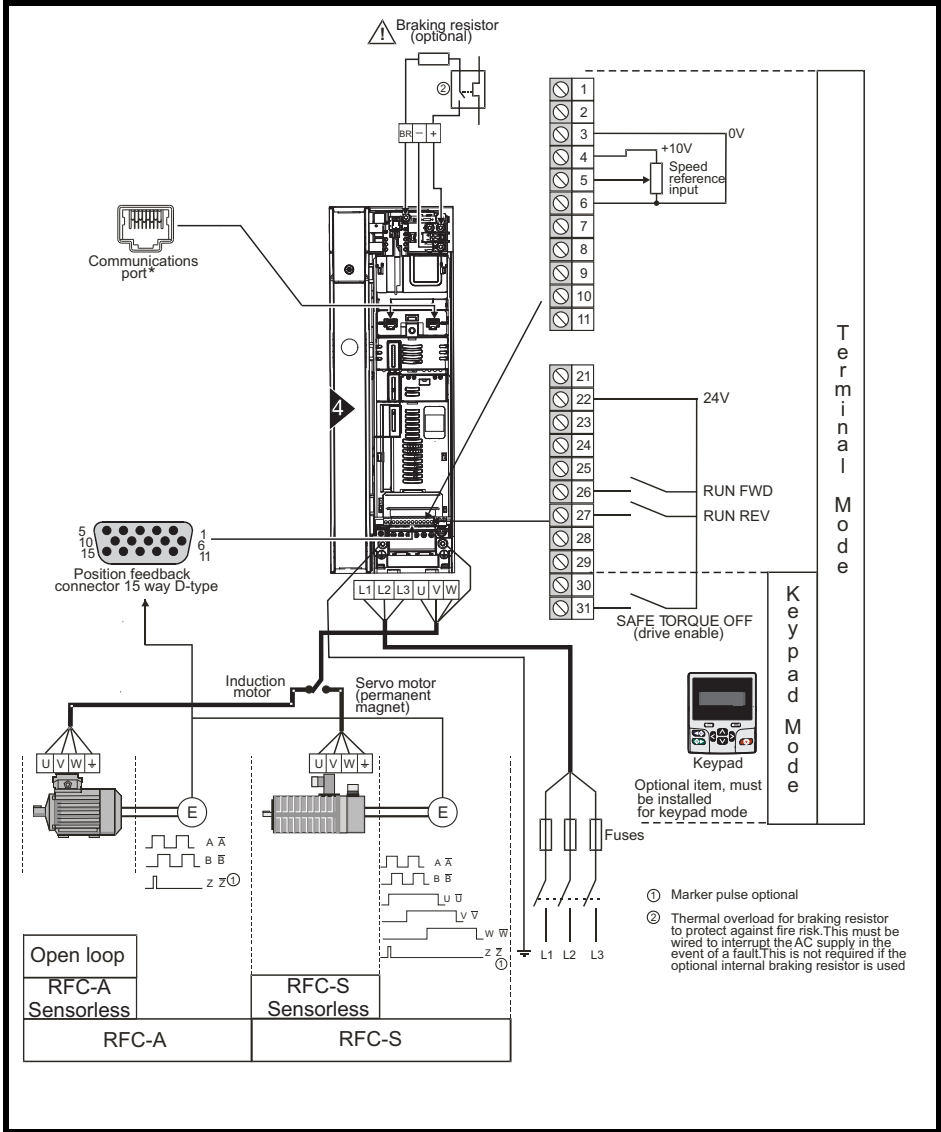

Active action icon	Description	Row (1=top)	Priority in row
	Accessing non-volatile media card	1	1
	Alarm active	1	2
	Keypad real-time clock battery low	1	3
or	Drive security active and locked or unlocked	1	4
	Motor map 2 active	2	1
	User program running	3	1
	Keypad reference active	4	1

Quick Start/Start-up

Quick Start Connections (Frame 4 Illustrated)

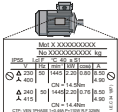
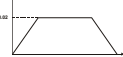
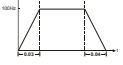

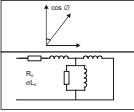





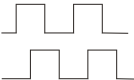

Open-loop

Action	Detail	
Before power-up	Ensure: <ul style="list-style-type: none"> The drive enable signal is not given (terminal 31) Run signal is not given Motor is connected 	
Power-up the drive	NOTE Drive powers up from Factory Default in Open Loop Mode If Open-loop mode is displayed when the drive is powered up: <ul style="list-style-type: none"> If the frequency of the mains supply is 60 Hz, set Pr 00.000 = 1244, otherwise if the frequency of the mains is 50 Hz, set Pr 00.000 = 1233. If RFC-A or RFC-S mode is displayed when the drive is powered up: <ul style="list-style-type: none"> Set Pr 00.048 = Open-loop (1). If the frequency of the mains supply is 60 Hz, set Pr 00.000 = 1254, otherwise if the frequency of the mains is 50 Hz, Pr 00.000 = 1253. Press the red Reset button or toggle the Reset logic input. Ensure: Drive displays 'Inhibit'	
Enter motor nameplate details	Enter: <ul style="list-style-type: none"> Motor rated frequency in Pr 00.047 (Hz) Motor rated current in Pr 00.046 (A) Motor rated speed in Pr 00.045 (rpm) Motor rated voltage in Pr 00.044 (V) - check if Δ or Λ connection 	
Set max frequency	Enter: <ul style="list-style-type: none"> Maximum frequency in Pr 00.002 (Hz) 	
Set accel. / decel. rates	<ul style="list-style-type: none"> Acceleration rate in Pr 00.003 (s /100 Hz) Deceleration rate in Pr 00.004 (s /100 Hz) (If braking resistor installed, set Pr 00.015 = FAST. Also ensure Pr 10.030, Pr 10.031 and Pr 10.061 are set correctly, otherwise premature 'Brake R Too Hot' trips may be seen). It is possible to change the units to be s / Maximum frequency, if Pr 02.039 = On.	
Select or deselect catch a spinning motor mode	If catch a spinning motor is required then set Pr 06.009 = Enable, FWD only or Rev only, if it is not required set to Disable. Depending on the size of the motor, the value in Pr 05.040 may need to be adjusted. Pr 05.040 defines a scaling function used by the algorithm that detects the speed of the motor. The default value of Pr 05.040 is 1 which is suitable for small motors (<4 kW). For larger motors the value in Pr 05.040 will need to be increased.	
Motor thermistor set-up	If a thermistor is connected to terminal 8, then the <i>Analog Input 3 Mode</i> (07.015) parameter must be set to Thermistor Short Cct (7), Thermistor (8) or Therm No Trip (9).	
Autotune	The drive is able to perform either a stationary or a rotating autotune. The motor must be at a standstill before an auto-tune is enabled. A rotating autotune should be used whenever possible so the measured value of power factor of the motor is used by the drive <div style="border: 1px solid black; padding: 5px; margin-top: 10px;">  <p>A rotating autotune will cause the motor to accelerate up to $2/3$ base speed in the direction selected regardless of the reference provided. Once complete the motor will coast to a stop. The enable signal must be removed before the drive can be made to run at the required reference.</p> </div> <p>To perform an autotune:</p> <ul style="list-style-type: none"> Set Pr 00.040 = 1 for a stationary autotune or set Pr 00.040 = 2 for a rotating autotune Close the Drive Enable signal (terminal 31). The drive will display 'Ready'. Close the run signal (terminal 26 or 27). The lower display will flash 'Autotune' while the drive is performing the autotune. Wait for the drive to display 'Ready' or 'Inhibit' and for the motor to come to a standstill. Remove the drive enable and run signal from the drive. 	
Save parameters	Select 'Save Parameters' in Pr mm.000 (alternatively enter a value of 1001 in Pr mm.000) and press red  reset button or toggle the reset digital input.	
Run	Drive is now ready to run	

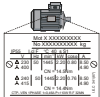
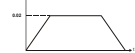
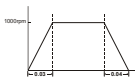



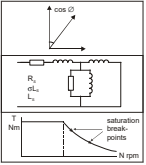

RFC-A (with position feedback)



Only an incremental quadrature encoder will be considered here.

Action	Detail	
Before power-up	Ensure: <ul style="list-style-type: none"> • Drive Enable signal is not given (terminal 31) • Run signal is not given • Motor and feedback device are connected 	
Power-up the drive	<p>NOTE Drive powers up from Factory Default in Open Loop Mode</p> <p>If RFC-A mode is displayed when the drive is powered up:</p> <ul style="list-style-type: none"> • If the frequency of the mains supply is 60 Hz, set Pr 00.000 = 1244, otherwise if the frequency of the mains is 50 Hz, set Pr 00.000 = 1233. <p>If Open Loop or RFC-S mode is displayed when the drive is powered up:</p> <ul style="list-style-type: none"> • Set Pr 00.048 = RFC-A (2). • If the frequency of the mains supply is 60Hz, set Pr 00.000 = 1254, otherwise if the frequency of the mains is 50 Hz, Pr 00.000 = 1253. <p>Press the red Reset button or toggle the Reset logic input.</p> <p>Drive may be tripped with a Wirebreak trip, but this will be addressed once the encoder is set up.</p>	
Set motor feedback parameters	<p>Incremental encoder basic set-up</p> <p>Enter:</p> <ul style="list-style-type: none"> • Drive encoder type in Pr 03.038 = AB (0): Quadrature encoder • Encoder power supply in Pr. 03.036 = 5 V (0), 8 V (1) or 15 V (2). <p>NOTE If output voltage from the encoder is > 5 V, then the termination resistors must be disabled Pr 03.039 to 0.</p> <div style="border: 1px solid black; padding: 5px; margin: 10px 0;">  <p>Setting the encoder voltage supply too high for the encoder could result in damage to the feedback device.</p> </div> <ul style="list-style-type: none"> • Drive encoder Lines Per Revolution (LPR) in Pr 03.034 • Drive encoder termination resistor setting in Pr 03.039: <ul style="list-style-type: none"> 0 = A-AI, B-BI, Z-ZI termination resistors disabled 1 = A-AI, B-BI, termination resistors enabled, Z-ZI termination resistors disabled. 2 = A-AI, B-BI, Z-ZI termination resistors enabled <p>Set P03.026 = P1 Drive</p>	
Motor thermistor set-up	<p>If a thermistor is connected to terminal 8, then the <i>Analog Input 3 Mode</i> (07.015) parameter must be set to Thermistor Short Cct (7), Thermistor (8) or Therm No Trip (9).</p> <p>NOTE The thermistor input will be disabled until Pr 07.015 is set to one of the above.</p>	
Enter motor nameplate details	<ul style="list-style-type: none"> • Motor rated frequency in Pr 00.047 (Hz) • Motor rated current in Pr 00.046 (A) • Motor rated speed in Pr 00.045 (rpm) • Motor rated voltage in Pr 00.044 (V) - check if Δ or Λ connection 	
Set max speed	<p>Enter:</p> <ul style="list-style-type: none"> • Maximum speed in Pr 00.002 (rpm) 	
Set accel / decel rates	<p>Enter:</p> <ul style="list-style-type: none"> • Acceleration rate in Pr 00.003 (s/1000 rpm) • Deceleration rate in Pr 00.004 (s/1000 rpm) (If braking resistor installed, set Pr 00.015 = FAST. Also ensure Pr 10.030, Pr 10.031 and Pr 10.061 are set correctly, otherwise premature 'Brake R Too Hot' trips may be seen). 	

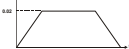
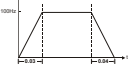



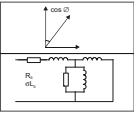

Action	Detail	
Select or deselect catch a spinning motor mode	<p>If catch a spinning motor is required then set Pr 06.009= Enable, FWD only or Rev only, if it is not required set to Disable.</p> <p>Depending on the size of the motor, the value in Pr 05.040 may need to be adjusted. Pr 05.040 defines a scaling function used by the algorithm that detects the speed of the motor. The default value of Pr 05.040 is 1 which is suitable for small motors (<4 kW). For larger motors the value in Pr 05.040 will need to be increased.</p>	
Autotune	<p>The drive is able to perform either a stationary or a rotating autotune. The motor must be at a standstill before an autotune is enabled. A stationary autotune will give moderate performance whereas a rotating autotune will give improved performance as it measures the actual values of the motor parameters required by the drive.</p> <div data-bbox="213 368 857 480" style="border: 1px solid black; padding: 5px;">  <p>A rotating autotune will cause the motor to accelerate up to $\frac{2}{3}$ base speed in the direction selected regardless of the reference provided. Once complete the motor will coast to a stop. The enable signal must be removed before the drive can be made to run at the required reference.</p> </div> <p>To perform an autotune:</p> <ul style="list-style-type: none"> • Set Pr 00.040 = 1 for a stationary autotune or set Pr 00.040 = 2 for a rotating autotune • Close the drive enable signal (terminal 31). The drive will display 'Ready'. • Close the run signal (terminal 26 or 27). The lower display will flash 'Autotune' while the drive is performing the autotune. • Wait for the drive to display 'Ready' or 'Inhibit' and for the motor to come to a standstill • Remove the drive enable and run signal from the drive. 	
Save parameters	<p>Select 'Save Parameters' in Pr mm.000 (alternatively enter a value of 1001 in Pr mm.000) and press red  reset button or toggle the reset digital input.</p>	
Run	<p>Drive is now ready to run</p>	



RFC-A sensorless

Action	Detail	
Before power-up	Ensure: <ul style="list-style-type: none"> • The drive enable signal is not given (terminal 31) • Run signal is not given • Motor is connected 	
Power-up the drive	<p>NOTE Drive powers up from Factory Default in Open Loop Mode</p> <p>If RFC-A mode is displayed when the drive is powered up:</p> <ul style="list-style-type: none"> • If the frequency of the mains supply is 60 Hz, set Pr 00.000 = 1244, otherwise if the frequency of the mains is 50 Hz, set Pr 00.000 = 1233. <p>If Open Loop or RFC-S mode is displayed when the drive is powered up:</p> <ul style="list-style-type: none"> • Set Pr 00.048 = RFC-A (2). • If the frequency of the mains supply is 60 Hz, set Pr 00.000 = 1254, otherwise if the frequency of the mains is 50 Hz, Pr 00.000 = 1253. <p>Press the red Reset button or toggle the Reset logic input. Ensure: Drive displays 'Inhibit'.</p>	
Select RFC-A (Sensorless control) mode	<ul style="list-style-type: none"> • Set Pr 03.024 = 1 or 3 to select RFC-A Sensorless mode • Set Pr 03.040 = 0000 to disable the wire break 	
Motor thermistor set-up	<p>If a thermistor is connected to terminal 8, then the <i>Analog Input 3 Mode</i> (07.015) parameter must be set to Thermistor Short Cct (7), Thermistor (8) or Therm No Trip (9).</p> <p>NOTE The thermistor input will be disabled until Pr 07.015 is set to one of the above.</p>	
Enter motor nameplate details	<ul style="list-style-type: none"> • Motor rated frequency in Pr 00.047 (Hz) • Motor rated current in Pr 00.046 (A) • Motor rated speed in Pr 00.045 (rpm) • Motor rated voltage in Pr 00.044 (V) - check if Δ or Y connection 	
Set max speed	Enter: <ul style="list-style-type: none"> • Maximum frequency in Pr 00.002 (rpm) 	
Set accel. / decel. rates	<ul style="list-style-type: none"> • Acceleration rate in Pr 00.003 (s /1000 rpm) • Deceleration rate in Pr 00.004 (s /1000 rpm) (If braking resistor installed, set Pr 00.015 = FAST. Also ensure Pr 10.030, Pr 10.031 and Pr 10.061 are set correctly). 	
Select or deselect catch a spinning motor mode	<p>If catch a spinning motor is required then set Pr 06.009= Enable, FWD only or Rev only, if it is not required set to Disable.</p> <p>Depending on the size of the motor, the value in Pr 05.040 may need to be adjusted. Pr 05.040 defines a scaling function used by the algorithm that detects the speed of the motor. The default value of Pr 05.040 is 1 which is suitable for small motors (<4 kW). For larger motors the value in Pr 05.040 will need to be increased.</p>	

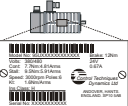
Action	Detail	
Autotune	<p>The drive is able to perform either a stationary or a rotating autotune. The motor must be at a standstill before an autotune is enabled. A stationary autotune will give moderate performance whereas a rotating autotune will give improved performance as it measures the actual values of the motor parameters required by the drive.</p> <p>NOTE It is highly recommended that a rotating autotune is performed (Pr 00.040 set to 2).</p> <div style="border: 1px solid black; padding: 5px; margin: 10px 0;">  <p>A rotating autotune will cause the motor to accelerate up to $\frac{2}{3}$ base speed in the direction selected regardless of the reference provided. Once complete the motor will coast to a stop. The enable signal must be removed before the drive can be made to run at the required reference. The drive can be stopped at any time by removing the run signal or removing the drive enable.</p> </div> <p>To perform an auto-tune:</p> <ul style="list-style-type: none"> • Set Pr 00.040 = 1 for a stationary autotune or set Pr 00.040 = 2 for a rotating autotune. • Close the drive enable signal (terminal 31). The drive will display 'Ready' or 'Inhibit'. • Close the run signal (terminal 26 or 27). The lower display will flash 'Autotune' while the drive is performing the autotune. • Wait for the drive to display 'Ready' or 'Inhibit' and for the motor to come to a standstill. • Remove the drive enable and run signal from the drive. 	
Save parameters	Select 'Save Parameters' in Pr mm.000 (alternatively enter a value of 1001 in Pr mm.000) and press red  reset button or toggle the reset digital input.	
Run	Drive is now ready to run 	

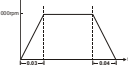

RFC-S with position feedback

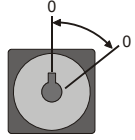
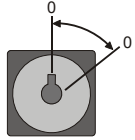

Action	Detail	
Before power-up	Ensure: <ul style="list-style-type: none"> The drive enable signal is not given (terminal 31) Run signal is not given Motor and feedback device are connected 	
Power-up the drive	<p>NOTE Drive powers up from Factory Default in Open Loop Mode If RFC-S mode is displayed when the drive is powered up:</p> <ul style="list-style-type: none"> If the frequency of the mains supply is 60 Hz, set Pr 00.000 = 1244, otherwise if the frequency of the mains is 50 Hz, set Pr 00.000 = 1233. <p>If Open Loop or RFC-A mode is displayed when the drive is powered up:</p> <ul style="list-style-type: none"> Set Pr 00.048 = RFC-S (3). If the frequency of the mains supply is 60 Hz, set Pr 00.000 = 1254, otherwise if the frequency of the mains is 50 Hz, Pr 00.000 = 1253. <p>Press the red Reset button or toggle the Reset logic input. These actions may leave the drive in a tripped state, but trips should be addressed by settings made within this procedure.</p>	
Set motor feedback parameters	<p>Incremental encoder basic set-up Enter:</p> <ul style="list-style-type: none"> Drive encoder type in Pr 03.038 = AB Servo (3): Quadrature encoder with commutation outputs Encoder power supply in Pr 03.036 = 5 V (0), 8 V (1) or 15 V (2). <p>NOTE If output voltage from the encoder is > 5 V, then the termination resistors must be disabled Pr 03.039 to 0.</p> <div style="border: 1px solid black; padding: 5px; margin: 10px 0;">  <p>Setting the encoder voltage supply too high for the encoder could result in damage to the feedback device</p> </div> <ul style="list-style-type: none"> Drive encoder Pulses Per Revolution in Pr 03.034 (set according to encoder) Drive encoder termination resistor setting in Pr 03.039: <ul style="list-style-type: none"> 0 = A-A\, B-B\, Z-Z\ termination resistors disabled 1 = A-A\, B-B\, termination resistors enabled, Z-Z\ termination resistors disabled 2 = A-A\, B-B\, Z-Z\ termination resistors enabled 	
Motor thermistor set-up	<p>At factory default, terminal 8 is set-up for an analog voltage input. If a thermistor is connected to terminal 8, then the <i>Analog Input 3 Mode</i> (07.015) parameter must be set to Thermistor Short Cct (7), Thermistor (8) or Therm No Trip (9).</p> <p>NOTE The thermistor input will be disabled until Pr 07.015 is set to one of the above.</p>	
Enter motor nameplate details	<p>Enter:</p> <ul style="list-style-type: none"> Motor rated current in Pr 00.046 (A) Ensure that this equal to or less than the Heavy Duty rating of the drive otherwise 'Motor Too Hot' trips may occur during the autotune. Number of poles in Pr 00.042 Motor rated voltage in Pr 00.044 (V) 	
Set maximum speed	<p>Enter:</p> <ul style="list-style-type: none"> Maximum speed in Pr 00.002 (rpm) 	
Set accel / decel rates	<ul style="list-style-type: none"> Acceleration rate in Pr 00.003 (s/1000 rpm) Deceleration rate in Pr 00.004 (s/1000 rpm) (If braking resistor installed, set Pr 00.015 = Fast. Also ensure Pr 10.030, Pr 10.031 and Pr 10.061 are set correctly, otherwise premature 'Brake R Too Hot' trips may be seen). 	

Action	Detail	
Select or deselect catch a spinning motor mode	<p>If catch a spinning motor is required then set Pr 06.009= Enable, FWD only or Rev only, if it is not required set to Disable.</p> <p>Depending on the size of the motor, the value in Pr 05.040 may need to be adjusted. Pr 05.040 defines a scaling function used by the algorithm that detects the speed of the motor. The default value of Pr 05.040 is 1 which is suitable for small motors (<4 kW). For larger motors the value in Pr 05.040 will need to be increased.</p>	
Autotune	<p>The drive is able to perform either a stationary or a rotating autotune. The motor must be at a standstill before an autotune is enabled. A stationary autotune will give moderate performance whereas a rotating autotune will give improved performance as it measures the actual values of the motor parameters required by the drive. The drive is able to perform a stationary, rotating, mechanical load measurement or locked rotor test autotune. The motor must be at a standstill before an autotune is enabled. It is suggested that a rotating autotune is used for accurate measurement for position feedback phase angle.</p> <div style="border: 1px solid black; padding: 5px; margin: 10px 0;">  <p>The rotating autotune will rotate the motor by up to 2 mechanical revolutions in the direction selected, regardless of the reference provided. After a short delay, the motor is further rotated through an electrical revolution. The enable signal must be removed before the drive can be made to run at the required reference. The drive can be stopped at any time by removing the run signal or removing the drive enable.</p> </div> <p>To perform an autotune:</p> <ul style="list-style-type: none"> • Set Pr 00.040 = 1 for a stationary autotune, Pr 00.040 = 2 for a rotating autotune. • Close the run signal (terminal 26 or 27). • Close the drive enable signal (terminal 31). The lower display will flash 'Autotune' while the drive is performing the test. • Wait for the drive to display 'Ready' or 'Inhibit' and for the motor to come to a standstill. <p>If the drive trips it cannot be reset until the drive enable signal (terminal 31) has been removed.</p> <ul style="list-style-type: none"> • Remove the drive enabled and run signal from the drive. 	
Save parameters	<p>Select 'Save Parameters' in Pr mm.000 (alternatively enter a value of 1001 in Pr mm.000) and press red  reset button or toggle the reset digital input.</p>	
Run	<p>Drive is now ready to run</p>	

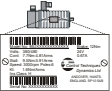
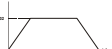
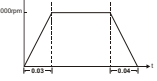

RFC-S (Sensorless)

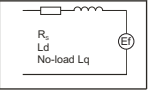
Action	Detail	
Before power-up	Ensure: <ul style="list-style-type: none"> The drive enable signal is not given (terminal 31 on Unidrive M700/M701). Run signal is not given Motor is connected 	
Power-up the drive	<p>NOTE Drive powers up from Factory Default in Open Loop Mode</p> <p>If RFC-S mode is displayed when the drive is powered up:</p> <ul style="list-style-type: none"> If the frequency of the mains supply is 60 Hz, set Pr 00.000 = 1244, otherwise if the frequency of the mains is 50 Hz, set Pr 00.000 = 1233. <p>If Open Loop or RFC-A mode is displayed when the drive is powered up:</p> <ul style="list-style-type: none"> Set Pr 00.048 = RFC-S (3). If the frequency of the mains supply is 60 Hz, set Pr 00.000 = 1254, otherwise if the frequency of the mains is 50 Hz, Pr 00.000 = 1253. <p>Press the red Reset button or toggle the Reset logic input.</p> <p>These actions may leave the drive in a tripped state, but trips should be addressed by settings made within this procedure.</p>	
Enter motor nameplate details	Enter: <ul style="list-style-type: none"> Motor rated current in Pr 00.046 (A) Ensure that this equal to or less than the Heavy Duty rating of the drive otherwise 'Motor Too Hot' trips may occur during the autotune. Number of poles in Pr 00.042 Motor rated voltage in Pr 00.044 (V) 	
Set maximum speed	Enter: <ul style="list-style-type: none"> Maximum speed in Pr 00.002 (rpm) 	
Set acceleration / deceleration rates	Enter: <ul style="list-style-type: none"> Acceleration rate in Pr 00.003 (s/1000 rpm). It is recommended that the ramp rates are increased from the default value of 0.200 s/1000 rpm. Deceleration rate in Pr 00.004 (s/1000 rpm) (if braking resistor installed, set Pr 00.015 = Fast. Also ensure Pr 10.030, Pr 10.031 and Pr 10.061 are set correctly, otherwise premature 'Brake R Too Hot' trips may be seen). <p>It is possible to change the units to be s / Maximum frequency, if Pr 02.039 = On.</p>	
Select or deselect catch a spinning motor mode	<p>If catch a spinning motor is required then set Pr 06.009= Enable, FWD only or Rev only, if it is not required set to Disable.</p> <p>Depending on the size of the motor, the value in Pr 05.040 may need to be adjusted. Pr 05.040 defines a scaling function used by the algorithm that detects the speed of the motor. The default value of Pr 05.040 is 1 which is suitable for small motors (<4 kW). For larger motors the value in Pr 05.040 will need to be increased.</p>	
Set stop mode	Enter: <ul style="list-style-type: none"> Set Stop Mode to Ramp in Pr 06.001 	
Set hold zero speed	Enter: <ul style="list-style-type: none"> Set Hold Zero Speed to Off (0) in Pr 06.008. 	

Action	Detail	
Autotune	<p>The drive is able to perform a stationary autotune. The motor must be at a standstill before an autotune is enabled. A stationary autotune will give moderate performance.</p> <ul style="list-style-type: none"> A stationary autotune is performed to locate the flux axis of the motor. The stationary autotune measures the stator resistance, inductance in flux axis, inductance in torque axis with no load on the motor and values relating to deadtime compensation from the drive. Measured values are used to calculate the current loop gains, and at the end of the test the values in Pr 00.038 and Pr 00.039 are updated. <p>To perform an autotune:</p> <ul style="list-style-type: none"> Set Pr 00.040 = 1 or 2 for a stationary autotune. (Both perform the same tests). Close the run signal (terminal 26 or 27 on Unidrive M700/M701 and terminal 7 or 8 on Unidrive M702). Close the drive enable signal (terminal 31 on Unidrive M700/M701 and terminal 11 & 13 on Unidrive M702). The upper row of the display will flash 'Auto Tune' while the drive is performing the test. Wait for the drive to display 'Ready' or 'Inhibit' and for the motor to come to a standstill. <p>If the drive trips it cannot be reset until the drive enable signal (terminal 31) has been removed.</p> <ul style="list-style-type: none"> Remove the drive enabled and run signal from the drive. 	
Check Saliency	<p>In sensorless mode, when the motor speed is below Pr 00.045 / 10, a special low speed algorithm must be used to control the motor. There are two modes available, with the mode chosen based on the saliency of the motor. The ratio No-load Lq (Pr 00.056) / Ld (Pr 05.024) provides a measure of the saliency. If this value is > 1.1, then Injection (0) mode may be used. Current (2) mode may be used (but with limitations). If this value is < 1.1, then Current (2) mode must be used (this is the default of Pr 05.064).</p>	
Set low speed mode	<p>If the saliency value is < 1.2 (1.1 for firmware V01.21.01.00 or earlier), then set Pr 05.064 = Current (2). The output current level during starting and low speed operation is defined by Pr 05.071. Pr 05.071 should be set at a value 10% higher than the current for the maximum expected load, unless the motor inertia is high compared to the motor inertia, in which case a matching value should be set.</p> <p>If the saliency value is > 1.2 (1.1 for firmware V01.21.01.00 or earlier), then set Pr 05.064 = Injection (0). The output current level during starting and low speed operation is limited by Pr 05.071 to ensure that the saliency stays above this threshold. If difficulty is experienced with starting at higher load levels, it may be necessary to limit the maximum load by reducing Pr 05.071, or alternatively use Pr 05.064 = Current (2), with setup as above.</p>	
Set speed-loop gains	<p>The default values for Pr 00.007 and Pr 00.008 are good starting values. If the motor inertia is high compared to the motor inertia, Pr 00.007 may need to be increased</p>	
Set filters	<p>Reduce Pr 03.079 from the default value of 64 ms to 4 ms. If instability is experienced, increase Pr 00.017. If additional filtering is required, return Pr 00.017 to its initial value and increase Pr 03.079 to the next highest value, then increase Pr 00.017, as necessary.</p>	
Save parameters	<p>Select 'Save Parameters' in Pr mm.000 (alternatively enter a value of 1001 in Pr mm.000) and press red  reset button or toggle the reset digital input.</p>	
Run	<p>Drive is now ready to run</p>	







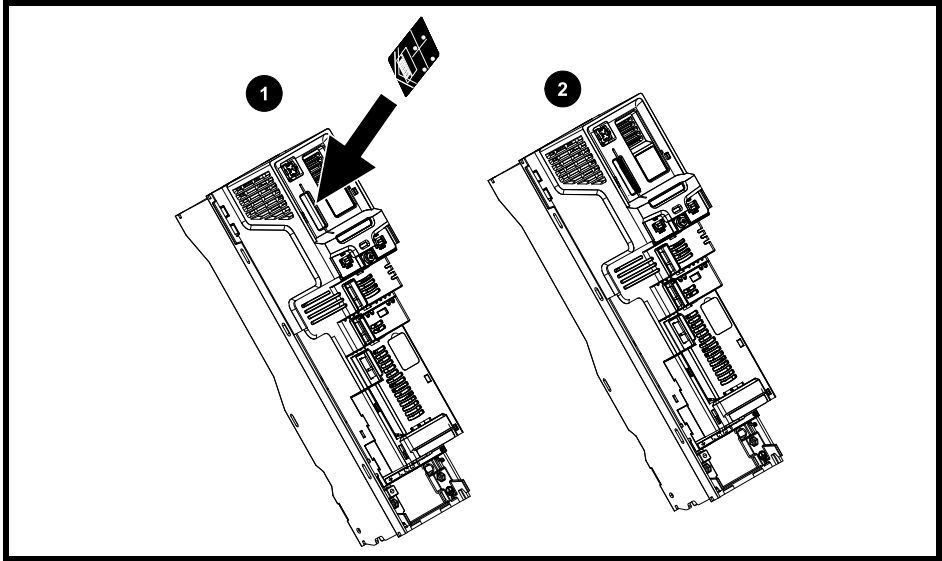

NV Media Card

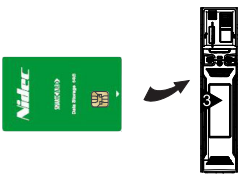
This allows simple configuration of parameters, parameter back-up and drive cloning.

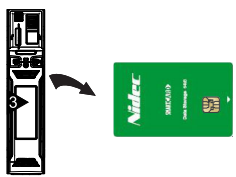
Installation of NV Media Card

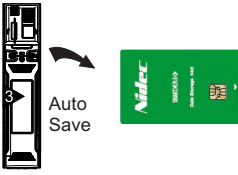

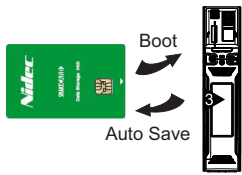
NV Media Card Basic Operation

<p>Drive reads all parameters from the NV Media Card</p>  <p>Pr 00.030 = Read + </p>	<p>Programs all drive parameters to the NV Media Card</p>  <p>NOTE Overwrites any data already in data block 1</p> <p>Pr 00.030 = Program + </p>
<p>Drive automatically writes to the Media Card when a parameter save is performed</p>  <p>Pr 00.030 = Auto + </p>	<p>Drive boots from the NV Media Card on power up and automatically writes to the Media Card when a parameter save is performed</p>  <p>Pr 00.030 = Boot + </p>

Basic Parameters

*RO - Read Only, RW - Read/Write

Parameter		Range			Default			Type
		OL	RFC-A	RFC-S	OL	RFC-A	RFC-S	
00.001	Minimum Reference Clamp (01.007)	±VM_NEGATIVE_REF_CLAMP1 Hz / rpm			0.0 Hz	0.0 rpm		RW
00.002	Maximum Reference Clamp (01.006)	±VM_POSITIVE_REF_CLAMP Hz / rpm			50Hz default: 50.0 Hz 60Hz default: 60.0 Hz	50Hz default: 1500.0 rpm 60Hz default: 1800.0 rpm	3000.0 rpm	RW
00.003	Acceleration Rate 1 (02.011)	±VM_ACCEL_R ATE s /100 Hz	±VM_ACCEL_RATE s /1000 rpm		5.0 s/100 Hz	2.000 s/1000 rpm	0.200 s/1000	RW
00.004	Deceleration Rate 1 (02.021)	±VM_ACCEL_R ATE s /100 Hz	±VM_ACCEL_RATE s /1000 rpm		10.0 s/100 Hz	2.000 s/1000 rpm	0.200 s/1000	RW
00.005	Reference Selector (01.014)	A1 A2 (0), A1 Preset (1), A2 Preset (2), Preset (3), Keypad (4), Precision (5), Keypad Ref (6)			A1 A2 (0)			RW
00.006	Symmetrical Current Limit (04.007)	±VM_MOTOR1_CURRENT_LIMIT %			165.0 %	175.0 %		RW
00.007	Open-loop Control Mode (05.014)	Ur S (0), Ur I (1), Fixed (2), Ur Auto (3), Ur I (4), Square (5), Current 1P (6)			Ur I (4)			RW
	Speed Controller Proportional Gain Kp1 (03.010)		0.0000 to 200.000 s/rad			0.0300 s/rad	0.0100 s/rad	RW
00.008	Low Frequency Voltage Boost (05.015)	0.0 to 25.0 %			Size 3 to 6: 3.0 % Size 7 & 8: 2.0 % Size 9≥: 1.0 %			RW
	Speed Controller Integral Gain Ki1 (03.011)		0.00 to 655.35 s ² /rad			0.10 s ² /rad	1.00 s ² /rad	RW
00.009	Dynamic V to F Select (05.013)	Off (0) or On (1)			Off (0)			RW
	Speed Controller Differential Feedback Gain Kd 1 (03.012)		0.00000 to 0.65535 1/rad			0.00000 1/rad		RW
00.010	Motor Rpm (05.004)	±180000 rpm			0 rpm			RW
	Speed Feedback (03.002)	±VM_SPEED rpm				0 rpm		RO
00.011	Output Frequency (05.001)	±VM_SPEED_F REQ_REF Hz	±2000.0 Hz		0.0 Hz			RO
	P1 Position (03.029)			0 to 65535			0	RO
00.012	Current Magnitude (04.001)	0.000 to VM_DRIVE_CURRENT_UNIPOLAR A						RO
00.013	Torque Producing Current (04.002)	VM_DRIVE_CURRENT A						RO
00.014	Torque Mode Selector (04.011)	0 or 1	0 to 5		0			RW
00.015	Ramp Mode (02.004)	Fast (0), Standard (1), Std boost (2)	Fast (0), Standard (1)		Standard (1)			RW
00.016	Ramp Enable (02.002)	OFF (0) or On (1)				On (1)		RW
00.017	Digital Input 6 Destination (08.026)	00.000 to 59.999			06.031			RW
	Current Reference Filter 1 Time Constant (04.012)				0.0 to 25.0 ms	0.0 ms		RW
00.018	P1 Thermistor Fault Detection (03.123)	0 to 2			None (0)		Temperature (1)	RW

Parameter			Range			Default			Type
			OL	RFC-A	RFC-S	OL	RFC-A	RFC-S	
00.019	Analog Input 2 Mode	{07.011}	4-20 mA Low (-4), 20-4 mA Low (-3), 4-20 mA Hold (-2), 20-4 mA Hold (-1), 0-20 mA (0), 20-0 mA (1), 4-20 mA Trip (2), 20-4 mA Trip (3), 4-20 mA (4), 20-4 mA (5), Volt (6)			Volt (6)			RW
00.020	Analog Input 2 Destination	{07.014}	00.000 to 59.999			01.037			RW
00.021	Analog Input 3 Mode	{07.015}	Volt (6), Therm Short Cct (7), Thermistor (8), Therm No Trip (9)			Volt (6)			RW
00.022	Bipolar Reference Enable	{01.010}	Off (0) or On (1)			Off (0)			RW
00.023	Jog Reference	{01.005}	0.0 to 400.0 Hz	0.0 to 4000.0 rpm		0.0 Hz	0.0 rpm		RW
00.024	Preset Reference 1	{01.021}	VM_SPEED_FREQ_REF			0.0 Hz	0.0 rpm		RW
00.025	Preset Reference 2	{01.022}	VM_SPEED_FREQ_REF			0.0 Hz	0.0 rpm		RW
00.026	Preset Reference 3	{01.023}	VM_SPEED_FREQ_REF Hz			0.0 Hz			RW
	Uni M: Overspeed Threshold	{03.008}	0 to 33000 rpm				0.0 rpm		RW
	Uni HS: Overspeed Threshold		0 to 60000 rpm						
00.027	Preset Reference 4	{01.024}	VM_SPEED_FREQ_REF Hz			0.0 Hz			RW
	P1 Rotary Lines Per Revolution	{03.034}	1 to 100000			1024	4096	RW	
00.028	Enable Auxiliary Key	{06.013}	0 to 5			Disabled (0)			RW
00.029	NV Media Card Data Previously Loaded	{11.036}	0 to 999			0			RO
00.030	Parameter cloning	{11.042}	None (0), Read (1), Program (2), Auto (3), Boot (4)			None (0)			RW
00.031	Drive Rated Voltage	{11.033}	200 V (0), 400 V (1), 575 V (2), 690 V (3)						RO
00.032	Maximum Heavy Duty Rating	{11.032}	0.000 to 99999.999 A						RO
00.033	Catch A Spinning Motor	{06.009}	Disable (0), Enable (1), Fwd Only (2), Rev Only (3)			Disable (0)			RW
	Rated Speed Optimization Select	{05.016}	Disabled (0), Classic slow (1), Classic fast (2), Combined (3), VARs only (4), Voltage only (5)			Disabled (0)		RW	
00.034	User Security Code	{11.030}	0 to 2 ³¹ -1			0			RW
00.035	Serial Mode*	{11.024}	8 2 NP (0), 8 1 NP (1), 8 1 EP (2), 8 1 OP (3), 8 2 NP M (4), 8 1 NP M (5), 8 1 EP M (6), 8 1 OP M (7), 7 2 NP (8), 7 1 NP (9), 7 1 EP (10), 7 1 OP (11), 7 2 NP M (12), 7 1 NP M (13), 7 1 EP M (14), 7 1 OP M (15)			8 2 NP (0)			RW
00.036	Serial Baud Rate*	{11.025}	300 (0), 600 (1), 1200 (2), 2400 (3), 4800 (4), 9600 (5), 19200 (6), 38400 (7), 57600 (8), 76800 (9), 115200 (10)			19200 (6)			RW
00.037	Serial Address*	{11.023}	1 to 247			1			RW
	Active IP Address**		000.000.000.000 to 255.255.255.255			0.0.0.0			RO
00.038	Current Controller Kp Gain	{04.013}	0 to 30000			20	150		RW
00.039	Current Controller Ki Gain	{04.014}	0 to 30000			40	2000		RW
00.040	Auto-tune	{05.012}	0 to 2	0 to 5	0 to 6	0			RW

Parameter		Range			Default			Type
		OL	RFC-A	RFC-S	OL	RFC-A	RFC-S	
00.041	Maximum Switching Frequency {05.018}	2 kHz (0), 3 kHz (1), 4 kHz (2), 6 kHz (3), 8 kHz (4), 12 kHz (5), 16 kHz (6)			3 kHz (1)		6 kHz (3)	RW
00.042	Number Of Motor Poles {05.011}	Automatic (0) to 480 Poles (240)			Automatic (0)		6 Poles (3)	RW
00.043	Rated Power Factor {05.010}	0.000 to 1.000			0.850			RW
	Position Feedback Phase Angle			0.0 to 359.9 °			0.0 °	RW
00.044	Rated Voltage {05.009}	0 to VM_AC_VOLTAGE_SET V			200 V drive: 230 V 50 Hz default 400 V drive: 400 V 60 Hz default 400 V drive: 460 V 575 V drive: 575 V 690 V drive: 690 V			RW
00.045	Uni M: Rated Speed {05.008}	0 to 35,940 rpm	0.00 to 33,000.00 rpm		50Hz default: 1500 rpm 60Hz default: 1800 rpm	50Hz default: 1500 rpm 60Hz default: 1800 rpm	3,000.00 rpm	RW
	Uni HS: Rated Speed	0 to 180,000 rpm	0 to 50,000 rpm					
00.046	Rated Current {05.007}	0.000 to VM_RATED_CURRENT			Maximum Heavy Duty Rating (11.032)			RW
00.047	Uni M: Rated Frequency {05.006}	0.0 to 599.0 Hz	0.0 to 550.0 Hz		50 Hz default: 50.0 Hz 60 Hz default: 60.0 Hz			RW
	Uni HS: Rated Frequency	0.0 to 3000 Hz	0.0 to 1667 Hz					
	Volts per 1000 rpm {05.033}			0 to 10000 V / 1000 rpm			98 V / 1000 rpm	RW
00.048	User Drive Mode {11.031}	Open-loop (1), RFC-A (2), RFC-S (3), Regen (4)			Open-loop (1)	RFC-A (2)	RFC-S (3)	RW
00.049	User Security Status {11.044}	Menu 0 (0), All Menus (1), Read-only Menu 0 (2), Read-only (3), Status Only (4), No Access (5)			Menu 0 (0)			RW
00.050	Software Version {11.029}	0 to 99999999			0			RO
00.051	Action On Trip Detection {10.037}	0 to 31			0x00			RW
00.052	Reset Serial Communications* {11.020}	Off (0) or On (1)			Off (0)			RW
00.053	Motor Thermal Time Constant 1 {04.015}	1.0 to 3000.0 s			89.0 s			RW
00.080	NV Media Card Action Status {11.078}	0 to 8			None (0)			RO

* Only applicable to Unidrive M701

** Only applicable to Unidrive M700

Diagnostics

For fault codes use following link:

<https://acim.nidec.com/drives/control-techniques/downloads/mobile-applications>

Download the Diagnostic Tool from the Control Techniques Website on the above link.

UL Information

UL file reference

These products are cUL Listed to Canadian and US requirements.

UL file reference is: NMMS/7 E171230.

Products that incorporate the Safe Torque Off (STO) function are Certified for Functional Safety.

UL file reference: FSPC E171230.

Operating environment

Pollution Degree

Products must be installed in a Pollution Degree 2 environment or better (dry, non-conductive pollution only).

Ambient temperature

The drives have been evaluated for use at ambient temperatures up to 40 °C. The drives have additionally been evaluated for 50 °C and 55 °C ambient air temperatures with a derated output.

The maximum surrounding air temperature is 55 °C.

Enclosure Ratings

Open Type

The products are Open Type as supplied.

Type 1

When fitted with a conduit box, the products meet the requirements for UL Enclosed Type 1. Suitable conduit boxes are available.

Through-panel (Type 12) mounting

Mounting hole access

When the drive is through-panel mounted, the main terminal cover(s) must be removed in order to provide access to the mounting holes. Once the drive has been mounted, the terminal cover(s) can be replaced.

Mounting bracket torque setting

Frame sizes 3 & 4

Through panel mounting brackets should be tightened to a maximum torque of 2 N m (16.8 lb in)

Installation in air handling spaces (plenum rating)

These products have been evaluated in accordance with the Standard for Fire Test for Heat and Visible Smoke Release for Discrete Products and their Accessories Installed in Air-Handling Spaces, UL 2043.

Products installed in air handling spaces must be Enclosed Type 1 as a minimum. A conduit box must be fitted. Alternatively, the product can be through-panel mounted in a Type 12 enclosure with the heatsink protruding through the wall of the enclosure into the air-handling space.

Mechanical Installation

Mounting

Products can be mounted on a vertical surface using the brackets provided. Several products may be mounted side by side without airspace between them.

In installations where space is limited, products with frame sizes 3, 4 and 5 may be 'Tile Mounted'. In this configuration, the unit is mounted sideways with the side panel against the mounting surface. A Tile Mounting Kit is available but must be ordered separately. See further details for part numbers in the Power Installation Guides.

Terminal Torque

Torque settings are specified in relevant sections of this guide.

Electrical Installation

Overvoltage category

Drives have been evaluated for OVC III

Branch circuit Protection

Branch circuit protection must be provided in accordance with the National Electrical Code (NEC), The Canadian Electrical Code, and any additional local codes.

The recommended fuses are specified within this guide.

Opening of branch circuit protective device

The opening of the branch-circuit protective device may be an indication that a fault has been interrupted. To reduce the risk of fire or electric shock, the equipment may be examined and replaced if damaged. If burnout of the current element of an overload relay occurs, the complete overload relay must be replaced. Integral solid-state short circuit protection does not provide branch circuit protection. Branch circuit protection must be provided in accordance with the National Electrical Code and any additional local "codes", or the equivalent.

Cables

Field wiring must use 75 °C rated copper wire only.

Ground connections

UL Listed closed-loop connectors sized according to the field wiring must be used for all ground connections.

Power connections

Frame sizes 3, 4 and 5: These frame sizes use plug-in terminal blocks for the power connections. Frame sizes 6 to 11: UL Listed closed loop connectors sized according to the field wiring must be used for all power connections.

Motor overload protection

All models incorporate internal overload protection for the motor load that does not require the use of an external or remote overload protection device. The protection level is adjustable with the maximum current overload being dependent on the values entered into the current limit parameters (**Pr4.005** motoring current limit, **Pr4.006** regenerative current limit and **Pr4.007** symmetrical current limit entered as percentage) and **Pr5.007** motor rated current parameter (entered in Amperes). The duration of the overload is dependent on **Pr4.015** motor thermal time constant.

Thermal memory retention

All models are provided with thermal memory retention.

Motor protection using an external sensor

User terminals are provided that can be connected to a motor thermistor to protect the motor from high temperature, in the event of a motor cooling fan failure.

Transient Surge Suppression

Frames sizes 7 & 8 – 575 V ratings

Transient surge suppression shall be installed on the line side of this equipment and shall be rated to 575 Vac (phase to ground), 575 Vac (phase to phase), suitable for overvoltage category III, and shall provide protection for an impulse withstand voltage peak of 6 kV and a clamping voltage of maximum 2400 V.

Dynamic braking

The drives have not been evaluated for dynamic braking.

External Class 2 supply

Frame sizes 7 to 11

The external power supply shall be marked with the following: "Class 2" and the power supply shall not exceed 24 Vdc.

Regenerative operation

Products can be configured as an AC Regenerative Unit (also known as a Regen drive). Regen operation allows bidirectional power flow to and from the AC supply. The AC supply voltage must not exceed:

Size 3 and 4: 480 Volts AC Maximum

Size 5 and 6: 575 Volts AC Maximum

Size 7 to 11: 600 Volts AC Maximum

In these systems the inverter output is connected to the AC supply via a reactor and switching frequency filter. The drives are required to be protected by listed branch fuses as specified in the installation instructions. For grid feed applications, further evaluation may be required to other standards, such as, but not limited to UL1741, CSA C22.2 No.107.1-01, IEEE 1547 etc.

Modular Drive Systems

Products with DC+ and DC- supply connections have been investigated for use in Modular Drive Systems as inverters when supplied by the converter sections from the Unidrive-M or Mentor MP range. In these applications the inverters are required to be additionally protected by supplemental fuses.

AC supply, AC supply fuses and short circuit current rating (SCCR)

Frame sizes 3 & 4

Suitable for use on a circuit capable of delivering not more than 100,000 RMS symmetrical Amperes, 480 Volts AC maximum when protected by the specified fuses.

UL Listed closed-loop connectors sized according to the field wiring shall be used for grounding connections. Frame size 6 only for closed loop connectors on all power connections (size 4 has a power connector like size 3 not studs)

Frame sizes 5 & 6

Suitable for use on a circuit capable of delivering not more than 100,000 RMS symmetrical Amperes, 575 Volts AC maximum when protected by the specified fuses.

Frame size 7 & 8

Suitable for use on a circuit capable of delivering not more than 100,000 RMS symmetrical Amperes, (rated voltage in the ratings table or the product label) Volts AC Maximum when protected by the specified fuses.

Frame sizes 9 & 10

Suitable for use on a circuit capable of delivering not more than 100,000 RMS symmetrical Amperes, (voltage rating in ratings table or the product label) Volts AC Maximum when protected by the specified fuses.

Frame size 11

Suitable for use on a circuit capable of delivering not more than 100,000 RMS symmetrical Amperes, (voltage rating in ratings table or the product label) Volts AC Maximum when protected by the specified fuses.

Modular / group / parallel installation**Supply wiring**

When used in modular drives/group / parallel installation applications the supply wires are not to be larger than 125 % of full load current of the device ratings

CSA (Canadian Standards Authority) approval

Frame sizes 9 to 11 are not certified for CSA approval when used in a modular / parallel setup

Supply from converters

These devices are only intended to be supplied by converters manufactured by Control Techniques Ltd. when used as inverters.



Warning Before using this product you must read and understand the safety information within the User Guide at the URL below.	Avertissement Avant d'utiliser ce produit, il est impératif de lire et de bien comprendre les consignes de sécurité du Guide de mise en service, disponible à l'adresse ci-dessous.
Avvertenza Prima di utilizzare questo prodotto leggere e assicurarsi di aver compreso le informazioni sulla sicurezza contenute nella Guida dell'utente consultabile all'URL indicato qui sotto.	Warnung Bevor Sie dieses Produkt verwenden, müssen Sie die Sicherheitshinweise in der Betriebsanleitung unter der nachstehenden URL lesen und verstehen.
Advertencia Antes de utilizar este producto, debe leer y comprender la información de seguridad de la Guía del usuario en la siguiente URL.	Предупреждение Преди да използвате този продукт, трябва да прочетете и разберете информацията за безопасност в ръководството за потребителя на URL адреса по-долу.
Upozorenje Prije upotrebe ovog proizvoda morate pročitati i razumjeti sigurnosne informacije iz Korisničkog vodiča na donjem URL-u.	Varování Před použitím tohoto výrobku si musíte na níže uvedené adrese URL přečíst v návodu k použití bezpečnostní informace a porozumět jim.
Προειδοποίηση Πριν από τη χρήση αυτού του προϊόντος, πρέπει να διαβάσετε και να κατανοήσετε τις πληροφορίες ασφαλείας που περιλαμβάνει ο Οδηγός χρήστη στην παρακάτω διεύθυνση.	Aviso Antes de utilizar este produto, deve ler e compreender as informações de segurança contidas no guia do utilizador que pode encontrar no URL abaixo.
Advarsel Før du tager dette produkt i brug, skal du have læst og forstået sikkerhedsoplysningerne i brugervejledningen på webadressen nedenfor.	Figyelem A termék használatá elött el kell olvasnia és meg kell értenie a Felhasználói útmutatóban található biztonsági információkat az alábbi URL-címen.
Avertizare Înainte de a utiliza acest produs, trebuie să citiți și să înțelegeți informațiile referitoare la siguranță din Ghidul de utilizare de la adresa URL de mai jos.	Waarschuwing Vóór gebruik van dit product moet u de veiligheidsinformatie in de Handleiding op de URL hieronder lezen en begrijpen..
Upozornenie Pred použitím tohto produktu si musíte prečítať a porozumieť všetkým bezpečnostným pokynom uvedeným v Používateľskej príručke, ktorú nájdete na nasledujúcej adrese URL.	Hoiatus Enne selle toote kasutamise alustamist peate lugema ja mõistma alltoodud URL-aadressil asuvas kasutusjuhendis toodud ohutusalaast teavet.
Bridinājums Pirms šā produkta lietošanas ir jāizlasa un jāizprot informācija par drošību, kas iekļauta lietošanas pamācībā tālāk norādītajā URL.	Opozorilo Pred uporabo tega izdelka morate prebrati in razumeti varnostne informacije v navodilih za uporabo na spodnjem spletnem naslovu.
Varoitus Ennen kuin käytät tätä tuotetta, sinun on luettava ja ymmärrettävä turvallisuusohjeet, jotka sisältyvät alla mainitussa verkko-osoitteessa olevaan käyttöoppaaseen.	İspējimas Prieš pradēdami naudoti šj gaminj perskaidykite ir jsiitinkite, kad supratote saugos informacijā, pateiktā naudotojo vadove, esančiame toliau nurodytu universaliu adresu.
Twissija Qabel ma tuża dan il-prodott inti għandek taqra u tifhem l-istruzzjonijiet ta' sikurezza fi hdan il-Gwida għall-Utent fil-URL t'isfel.	Varning Innan du använder denna produkt måste du läsa och förstå säkerhetsinformationen i användarhandboken på nedanstående URL-adress.
Ostrzeżenie Przed przystąpieniem do użytkowania produktu należy przeczytać ze zrozumieniem informacje dotyczące bezpieczeństwa przedstawione w Podręczniku użytkownika dostępnym pod następującym adresem.	

www.controltechniques.com/support

Control board

Power board

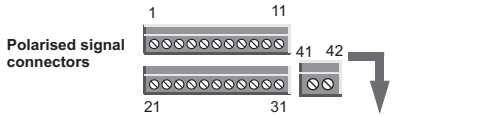

Frames 6 to 11 only

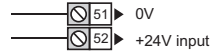

Frames 9 to 11 heatsink fan supply

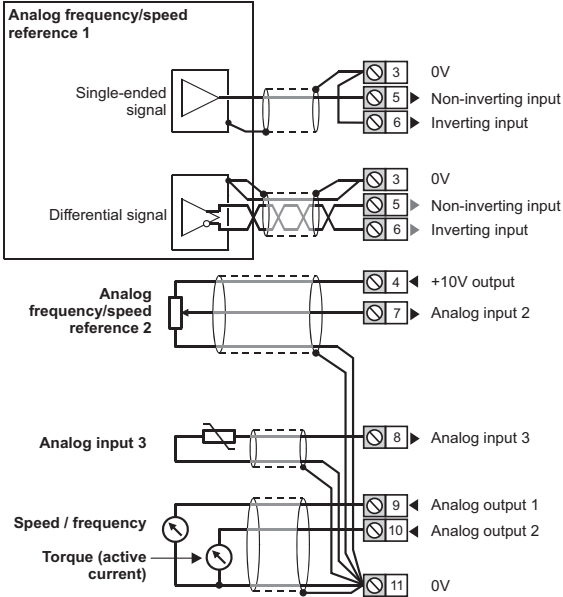
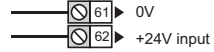

Supply Mode	Control Pod	Power Board Terminals	
Frame 6,7,8	1 (0V), 2 (24V)	51 (0V), 51 (24V) 60 W	61 (0V), 62 (24V) 168 W
Mains/DC Bus Only supply	X	X	N/A
24 V Back-up Supply/Low Voltage Mode	✓	✓	N/A
Frame 9,10,11			
Mains/DC Bus Only supply	X	X	X
24 V Back-up Supply	✓	✓	X
24 V Back-up Supply/Low Voltage Mode	✓	✓	✓

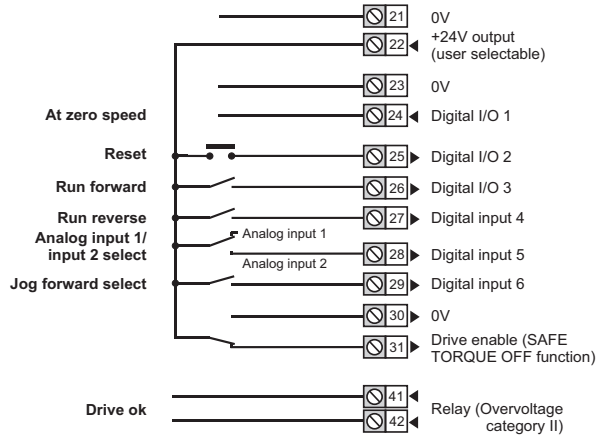

0478-0608-03